



Greening the Curricular of Building Construction Trade for Environmental Sustainability Through Fostering Waste Minimisation Skills

Samaila Hamza^{1*}, Aede Hatib Musta'amal @ Jamal², Yusri Kamin³

¹Faculty of Technology Education,
Abubakar Tafawa Balewa University, Bauchi, 740272 NIGERIA

^{2,3}School of Education,
Universiti Teknologi Malaysia, 81310 Johor, MALAYSIA

*Corresponding Author

DOI: <https://doi.org/10.30880/jtet.2020.12.03.008>

Received 11th March 2019; Accepted 25th November 2019; Available online 30th September 2020

Abstract: Waste minimisation skills became the subject of this research because construction industry generates lots of waste during and after construction. Therefore, the purpose of this quantitative study was to develop a conceptual model for integrating waste minimisation skills in Building Construction Trade (BCT) at technical colleges in Nigeria. This paper is aimed at exploring the negative effects of building construction wastes to environmental sustainability and identifying, using questionnaire through experts in building construction the important areas of waste minimisation skills suitable to be embedded into the curricular of building construction trade. Analysis of the identified important areas via Descriptive statistics (mean and standard deviation), Exploratory Factor analysis (EFA) and Confirmatory factor analysis (CFA) were used to analyse the data which will immensely contribute to the body of knowledge. The findings for this study include ability to manage waste, including custom diversion plans tailored to the project opportunities; consider that the selection and use of recyclable materials and products to minimise waste; and recycle waste generated from the process of intentional dismantling all or portions of a building. Using the results of the analysis, the research formulates a waste minimisation skills integration model, while Structural Equation Modelling (SEM) was used to validate the modified model and viable suggestions were made to the government for the adoption and practical implementation of the model by fostering the identified areas of the waste minimisation skills elements into the curriculum of building construction trade at technical colleges in Nigeria with the aimed for the environmental sustainability.

Keywords: Building Construction Trade, curriculum, environmental sustainability, greening, waste minimization skills

1. Introduction

The technological advancement and relevance in the world of any country depend largely on its achievement in technology education. Technology education according to Pavlova (2011), provides a prospect for students to

apprehend the nature of technology and its connections with society and the environment, and to plan and make products and systems in accord with the principles of sustainable development. Technology education in Nigeria as part of the formal education system is incorporated into the three levels of education, which are primary, secondary and tertiary with a view to meeting the nation's need for the skilled workforce and support the economic state of individual and the nation in general. Courses undertaken at those technical colleges include Building Construction Trade (BCT), Auto Mechanic Trade (AMT), Metal Work Trade (MWT) and Electrical/Electronic Trade (EET). Taking BCT into account, the curriculum of BCT is primarily aimed at giving training and imparting the necessary skills leading to the production of craftsmen, technicians and other skilled personnel who will be enterprising and self-reliant (National Board for Technical Education (NBTE), 2016a). Craftsmen in the construction industry play a very crucial role in the survival and growth of the industry as they are mostly engaged in the practical realisation of construction projects. This clearly indicates that, on successful graduation, BCT graduates are expected to acquire the necessary skills needed for the world of work. For the Pavlova (2011), the essence of technology education (which of course include building construction) is to involve students in learning within the model of sustainable development.

To this end, it is considerably important to note that, in order to achieve truly sustainable development especially in building construction area, which ranked among the number one energy consumers and greenhouse gas emission sector, we need to consider environmental sustainability factors. In line with this, Joseph and Tretsiakova-McNally (2010) remarked that buildings are the largest energy consumers and greenhouse gases emitters, both in developed and developing countries. More so, in the United States for example, the building sector consumes 49% of all energy produced in the United States Architecture 2030 (2015). Whereas in Germany, Beusker et al., (2012) reported that the existing building stock even accounts for a share of 30% of the final energy use. This, of course, hinders the environmental sustainability of these countries. With regards to sustainability, Illankoon *et al.* (2016) pointed out that the construction industry is unique in nature, it is worth discussing the concept of sustainability in a construction industry context. This is because environmental problems are a world-wide issue produced by unsustainable progress in many developing nations globally (Hamza et al., 2019).

Environmental sustainability in building construction sector involves the responsible use of raw materials; energy, water and awareness of the impacts of production processes and environmental auditing system. In line with this, Majumdar (2009) maintained that environmental sustainability as the first pillar of sustainability requires a change from "business as usual approach" to sustainable development approach of using natural resources wisely, minimising waste and limit damage to the atmosphere and check harmful climate change (Dobrovolskienė and Tamošiūnienė, 2015; Markelj et al., 2014). More so, the environmental dimension of sustainability is identified by some criteria and components; pollution, water consumption, waste management, greenhouse gas emission, use of durable materials, use of material with low health risk, use of renewable energy and environmental footprint. These criteria are in addition to responsible sourcing of material, use of locally available materials, recycling of components and materials, sensitive land protection, protection of ecological features, biodiversity and influence on outdoor microclimate (Markelj et al., 2014; Nevado-Peña et al., 2015; Sack, 2012). In line with this, Arasinah et al., (2020), Maintained that, although the Green skills essentials are taught in the educational institutions such as the use of recycled resources, these components are not extensively laid into practice.

In furtherance to UNESCO's assertion, Acedo (2014) demonstrate that there can be no sustainable development without education and without appropriate green skills for employability especially in the building construction sector. While Nigeria, as a developing country remains inactive on issues of sustainability. To support this assertion, Dania et al., (2013) contended that Nigeria is lagging behind world developments associated with sustainability within the construction sector and beyond. In line with the above, it was reported by Federal Republic of Nigeria FRN (2015) that the need for integrating the principles of sustainable development into country policies and programmes and reverse the loss of environmental resources in a bid to achieve the goal number 7 in the Millennium Development goals (MDG) on ensuring environmental sustainability in Nigeria (Federal Republic of Nigeria FRN, 2015). Moreover, Samaila et al., (2020) Viewed that if integration of green skills into building construction sector is successfully carried out will positively contribute towards the greening of the sector which is under TVET thereby attaining environmental protection and social, and economic viability. Conscientious looking at the aforementioned instances established the fact that there is need for fostering waste minimisation skills into the curriculum of BCT. Therefore, this research determine the important areas of waste minimisation skills; the relationship between the data samples and important areas of waste minimisation skills and found that there is a significant relationship between the research sample and

identified important areas of waste minimisation skills considered appropriate for integration in BCT for environmental sustainability in Nigeria.

1.1 Waste Minimisation Skills in Building Construction

Demand for refuse collectors is expected to be stable. In contrast, the demand for high-skilled workers involved in waste management collection and recycling activities is expected to increase in some countries around the world (European Centre for the Development of Vocational Training CEDEFOP, 2012). However, these activities may be required in the various sectors of the economy. Some of these economic sectors according to Bradshaw (2014) include green buildings, green cities, and greener transport among others. Connecting green economy with green job, Brown and Sack (2015) pointed out that green job is decent jobs that, limit greenhouse gas emissions; minimise waste and pollution and protect and restore ecosystems. In building construction sector, it is believed that constructions have both economic and environmental effect to the society. In line with this, Organisation for Economic Co-operation Development OECD (2015) maintained that construction is both a major part of the economy and, at the same time, has major environmental effects, especially regarding waste disposal. Consequently, OECD further emphasised that strategy should be developed for the construction sector, such as upgrading skills, incentives for the use of greener approaches (such as using recycled materials) and provisions for recycling construction and demolition waste. Precisely, this operation (reuse and recycle) in terms of waste requires a specific skill and this skill may be termed as waste skill.

Waste minimisation skills become the main subject of this research because the construction industry generates lots of waste during and after construction. The construction industry generates 25 per cent of municipal solid wastes and 50 per cent of the hazardous wastes (Arif et al., 2013). The waste minimisation skills are usually involved in reducing construction waste with a view to achieving sustainability. To this end, Manufacturing Skills Australia (2016) indicated that waste minimisation skills are meant to reducing the waste with a view to contributing to an improved environment that includes reduced energy, fuel, water and material use, less waste and emissions leading to better carbon footprint, reduced risk of environmental incidents. In essence, some building-related waste can be minimised by selecting on the basis of its designed and manufactured and shipped with minimal packaging or by the selection, and use of recyclable materials and products offers potential to minimise waste (Napier, 2012). In view of this proposal, it is pertinent to note that to properly minimise building-related waste wide range of skills are required. Additionally, building construction waste can either be minimised, reuse, recycle, reduce, recover, and remanufacture (Manufacturing Skills Australia, 2016; Napier, 2012). Elaborating further, (Napier) stressed that common sense suggests that failure to reduce, reuse and recycle societal wastes is unsustainable and definitely efficient and effective elimination and minimization of waste, and reuse of materials using creativity, and understanding of applicable regulations are important skills for design and construction professionals are essential aspects of design and construction activity.

The above-mentioned parameters on building waste that require skilful operation remain in the forefront in the waste minimisation in many countries. Due to this reason Australian Government (2012) posited that a person who demonstrates competency in the waste minimization unit must be able to provide evidence of the ability to source and analyse legislative and planning requirements for waste minimisation in the building process; calculate costs and savings of implementing alternative waste minimisation systems, and produce a strategy or plan for effective waste minimization. In line with this, waste minimisation skills is essentially needed for energy-efficient building by means of eliminating waste where possible; minimising waste where feasible, and reusing materials which might otherwise become waste.

Additionally, Kassim et al., (2005) maintained that sustainable waste management means that there is a need to: reduce the amount of waste produced by society; make the best use of waste produced by society; choose waste management practices that minimise the risk of immediate and future environmental pollution; and harm to human health. More so, Sarsvathy and Ramlee (2020) opined that green skills are required to produce competent students. And also reduce the quantity of waste, it is equally important to reduce its hazardous nature since it is nature as well as the quantity of waste that determines its potential for harming the environment. Building on the above, it is sufficient to note that skills are acquired for the purpose of accomplishing a task, waste minimisation skills according to Chiou *et al.* (2013) noted that green jobs are growing faster than overall job growth in the U.S. for example, and for this reason going “green” or “sustainable” is not an option, but a necessity in the building construction industries.

2. Method

This study is using Exploratory Sequential Mixed Method research design which consists of interviews for the qualitative part, and questionnaire survey for the quantitative part. However, this article will only report the quantitative part of this study. This section of the study was discussed based on the following sub-headings

2.1 Participants (Population) for The Study

In this study, two categories of respondents viz: building construction professionals in the construction industries and teachers at technical colleges in Nigeria. The target population was 308, made up of 214 BCT teachers and 94 building construction professionals. In all, proportionate stratified random sampling based on Krejcie and Morgan (1970) table for determining the sample size of a known population to sample 209 respondents (136 for teachers and 73 for professionals). Building on the above, in order to give every respondent equal chance to be selected, the researcher uses simple random sampling to select from each category of the respondents.

2.2 Data Collection

Data collection is a very important aspect of any educational research. The rationale behind data collection is its usefulness in considering the full range of possibilities for data collection in any study, and to organize these methods by their degree of predetermined nature, their focus for numeric versus non-numeric data analysis (Creswell, 2014). In this study, a quantitative instrument (structured questionnaire) was used in eliciting information from the respondents. A quantitative data collection approach brings breadth to this study by helping the researchers gather data about different aspects of this research phenomenon from many participants. The structured questionnaire was developed from an intensive literature review in line with specific objectives of the research in addition to the results of the qualitative data obtained using interview. Consequently, the 12 items structured questionnaire that was used in this study were the same for all the categories of respondents. It consists of two main sections "A" and "B". Section A solicits information on demographic characteristics of the respondents, while section B consisted of 12 items structured questions on the important areas of waste minimization skills needed for greening the BCT curriculum at technical colleges in Nigeria.

2.3 Data Analysis and Findings

In determining the findings of the study, appropriate method and statistical tools was used in the analysis of the data collected for this research. The quantitative data obtained from this study were analyzed using descriptive statistics such as (mean and standard deviation), Exploratory factor analysis (EFA), confirmatory factor analysis (CFA) and Structural Equation Modelling (SEM) with the help of IBM-SPSS version 21 and IBM-SPSS-AMOS (Analysis of Moment of Structures) version 18 statistical software packages (SPSS, 2011). EFA was applied (using 136 BCT teachers) to identify more appropriate areas of waste minimization skills by exploring and summarizing the underlying correlational structure for data collected using the 12 questionnaire items (Williams et al., 2010). CFA was conducted (using 73 Professionals) to tests the correlational structure of the set of data against the hypothesized structure and rate the goodness of fit of the analyzed data of the appropriate elements of waste Minimisation skills considered suitable for integration in BCT.

2.4 Exploratory Factor Analysis Waste Minimization Skills

In the following tables the results of EFA of waste minimisation skills, including estates of 10 items, WST1 to WST12 with the exception of WSM5 and WSM7 which were removed in the test of normality and outliers. The value of KMO was .871 which exceeded the factor analysis validity cut-off value of 0.500 recommended by (Beavers et al., 2013; Hair et al., 2012a). This threshold value was reinforced by the Bartlett's test of Sphericity which is significant at 0.000 which established that the results obtained were significant (Table 1). More so, there was a sizable inter-item correlations in the data signifying the existence of pattern relationship between the 10 variables; and all the corresponding anti-image AIs correlation diagonal values of the 10 items were greater than 0.5 (see table 1) proving the sampling adequacy of the data set. These results established that all the EFA assumptions were adequately satisfied (Comrey and Lee, 2013).

Table 1 - Measure of inter-item correlation and sampling adequacy.

KMO and Bartlett's Test			Item	Anti-image AI Corr. Diagonal
KMO (MSA)		.871	WST1	.878 ^a
Bartlett's Test of Sphericity	ACS	884.478	WST2	.887 ^a
	df	45	WST3	.905 ^a
	Sig.	.000	WST4	.747 ^a
			WST6	.893 ^a
			WST8	.743 ^a
			WST9	.863 ^a
			WST0	.905 ^a
			WST11	.881 ^a
			WST12	.866 ^a

Table 2 indicated that there were three components out of the nine components with initial eigenvalues greater than 1. These components communally accounted for **65.712%** of the variation in the actual variables which is greater than the minimum accepted variance explained of 60% recommended by (Hair et al., 2012b). This suggested that only two extracted factors had associative relationships. Similarly, the cumulative value of Extraction and Rotation Sums of Squared Loadings were also equals to **65.712%**. Hence, the variation explained by the initial solution has not been lost because of the latent factors which implied the suitability of the extraction method.

Table 2 - Total variance explained and matrix of waste minimization skills.

Component	Total Variance Explained								
	Initial Eigenvalues			Extraction Sums of Squared Loadings			Rotation Sums of Squared Loadings		
	Total	% of Variance	Cumulative %	Total	% of Variance	Cumulative %	Total	% of Variance	Cumulative %
1	4.298	47.762	47.762	4.298	47.762	47.762	4.011	44.456	44.456
2	1.615	17.950	65.712	1.615	17.950	65.712	1.913	21.256	65.712
3	0.742	8.244	73.956						
4	0.579	6.433	80.389						
5	0.492	5.467	85.856						
6	0.379	4.211	90.067						
7	0.343	3.811	93.878						
8	0.300	3.333	97.211						
9	0.261	2.789	100.000						

Table 3 presents the variance proportion perceived in every item in disparity to the other items, and the matrixes of WSMNSKILL. All of the values obtained were above 0.4 except that of WST3 (“*Gather materials which cannot efficiently and efficiently be reduced, curtailed or recycled eventually*”) which having reviewing its contents was deleted in EFA. These values denoted that the extraction communalities achieved through principal component analysis were satisfactory. In the factor analysis all the remaining items of waste minimisation skills (WSMNSKILL) were loaded into two factors.

Table 3 - Table of communalities and rotated component matrix.

Item	Communalities		Rotated Component Matrix ^a		
	Initial	Ext.	Item	1	2
WST1	1.000	.583	WST6	.738	
WST2	1.000	.500	WST9	.728	
WST3	1.000	.308	WST2	.705	
WST4	1.000	.691	WST11	.686	
WST6	1.000	.554	WST12	.672	
WST8	1.000	.409	WST1	.664	
WST9	1.000	.543	WST10	.584	
WST10	1.000	.400	WST4		.796
WST11	1.000	.479	WST8		.695
WST12	1.000	.478			

Factor 1 comprised of seven items which were WST10 (“*recycle waste generated from the process of intentional dismantling all or portions of a building.*”); WST1 (“*Use of durable modular metal form systems in concrete construction that may be readily demountable and reusable on other projects.*”); WST12 (“*Identify and dispose of hazardous materials in accordance with applicable regulations.*”); WST11 (“*Perform waste characterization studies to identify components which present known risks to human health and the environment.*”); WST2 (“*Reuse of materials such as doors, windows in good and resalable condition*”); WST9 (“*Reuse of waste generated by construction activities, such as scrap, damaged or spoiled materials.*”) and WST6 (“*Improve performance in metrics such as energy savings, water efficiency and CO2 emissions reduction.*”). Finally, factor 2 consisted of two items which were WST8 (“*Manage waste, including custom diversion plans tailored to the project opportunities.*”); and WST4 (“*Consider that the selection and use of recyclable materials and products to minimise waste.*”).

2.4.1 Measurement Model of Waste Management Skills

This section of the data analysis tested the measurement model of waste minimisation skills which addressed the research question and tested the hypothesis at >0.05 . Based on the results of EFA for the areas of waste minimisation skills elements, the variable of waste minimisation skills (WASMSKILL) was perceived as a second-order latent construct identified by three first-order latent constructs. Additionally, among the initial 10 measurement items of WASMSKILL, WST3 was deleted after the EFA, and the remaining 9 items were extracted into two factors (1, and 2). Building on the above, in CFA, the factor 2 of WASMSKILL in EFA as a first-order latent construct of WASMSKILL was named WAST1 which consisted of two items: WST8 and WST4; the factor 1 of WASMSKILL in EFA, also a first-order latent construct of WASMSKILL, was named WAST2 which consisted of seven items: WST10, WST1, WST12, WST11, WST2, WST9 and WST6.

In CFA of WASMSKILL via Amos 23, the computed values for model fit indices on measurement model (initial model) for waste minimisation skills in BCT curriculum, based on the results obtained, the validity inspection of measurement model of WASMSKILL indicated that the level of model fit was satisfied as the results of the standardised estimates (figure 1) that indicated that the value of CMIN was 74.945 with 26 DF. Although the p value associated with this result was significant at $p=.000$, and the sample size in this study for CFA was quite large ($N=209$), a significant p-value could be expected (Hair Jr, 2006). In addition, the normed CMIN (2.882) was accepted (between 1 and 3). More so, a good value of normal CMIN (less than 3) was enough to indicate a good model fit (Hair, 2010). The GFI (0.954) and AGFI (0.921) were both greater than 0.9; the CFI (0.937), TLI (0.913) were also greater than 0.9; and specifically, RMSEA was 0.072; a measure of less than 0.08 for RMSEA established the goodness-of-fit analysis. These results suggest that the measurement model of waste minimisation skills revealed a satisfactorily good fit; as all the variables had modification index (MI) value less than 15 which contributed to the fit of the model. Therefore, the hypothesis of a significant relationship between the data samples and important areas of waste

minimisation skills was hereby upheld at <0.05 and Figure 1 and Figure 2 were generated as measurement model and structural model respectively.

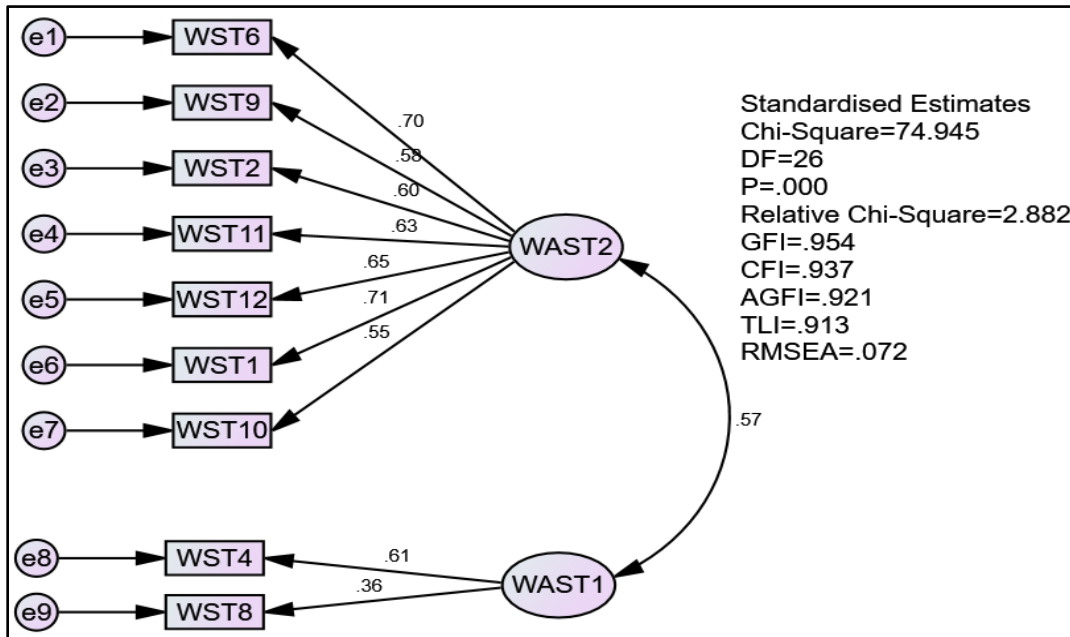

Fig. 1 - Measurement model of waste minimisation skills.

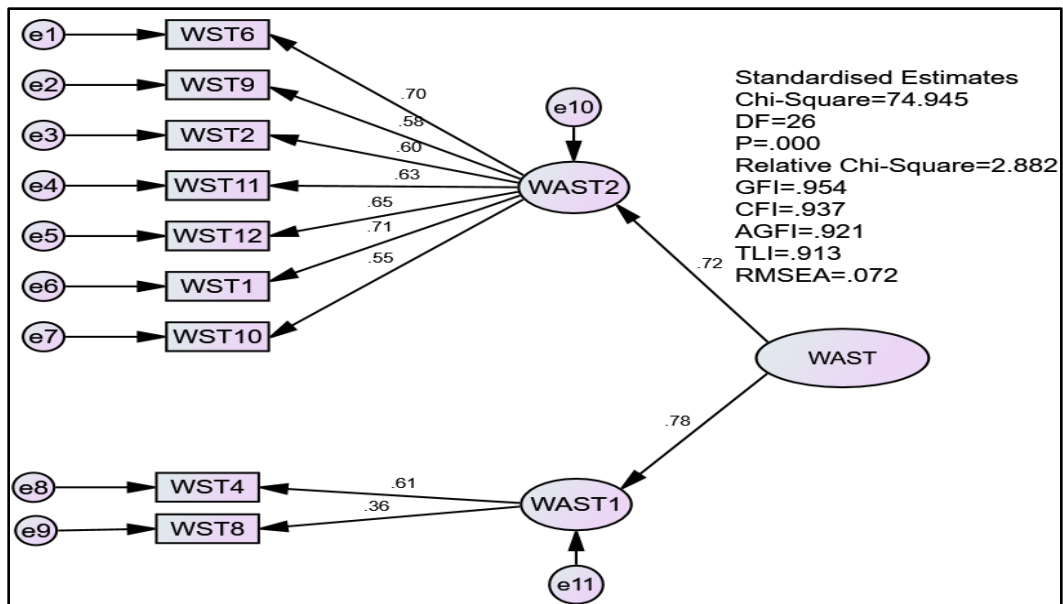

Fig. 2 - Structural model of waste minimisation skills.

Figures 1 and 2 shows a total of nine identified important areas of WASMSKILL: WST8 (“Manage waste, including custom diversion plans tailored to the project opportunities.”); WST4 (“Consider that the selection and use of recyclable materials and products to minimise waste.”); WST10 (“Recycle waste generated from the process of

intentional dismantling all or portions of a building.”);WST1 (“*Use of durable modular metal form systems in concrete construction that may be readily demountable and reusable on other projects.*”);WST12 (“*Identify and dispose of hazardous materials in accordance with applicable regulations.*”);WST11 (“*Perform waste characterization studies to identify components which present known risks to human health and the environment.*”);WST2 (“*Reuse of materials such as doors, windows in good and resalable condition*”);WST9 (“*Reuse of waste generated by construction activities, such as scrap, damaged or spoiled materials.*”); and WST6 (“*Improve performance in metrics such as energy savings, water efficiency and CO2 emissions reduction.*”); that were measured to determine their relationship with data sample for integration in BCT.

Figure 2, presented a structural model of the significant relationship between the data samples and the nine important areas of waste minimisation skills considered important for integration in BCT curriculum at technical colleges in Nigeria. Therefore, from the structural model (Figure 2) it can be concluded that for suitable integration of green skills into BCT curriculum important areas of waste minimisation skills should be put into consideration.

3. Discussion

This section discussed the findings of waste minimization skills in which experts were in consensus in integrating waste management and waste disposal which include the abilities to: re-use resources in decent and resalable condition; manage waste including custom diversion; and consider the selection and use of recyclable materials and product to minimise waste. These finding are supported by the recommendation of (UNESCO, 2012b) that TVET (including BCT) prepares learners for fields of work and business such as construction and waste management. Also, (Napier, 2012) confirmed that solid waste management practices have identified the reduction, recycling, and reuse of wastes as essential for sustainable management of resources. Additionally, Kassim, et al., (2005) maintained that sustainable waste management means that there is a need to; reduce the amount of waste produced by society, choose waste management practices that minimise the risk of immediate and future environmental pollution and to reduce its hazardous nature. Organisation for Economic Co-operation Development OECD (2015) recommended that since construction has major environmental effects, especially regarding waste disposal. In concise with this finding also, Chiou, et al., (2013) recommended that at times greenhouse gases, harmful emissions are generated during material processing, and waste disposal which creates pollution to the environment. Also, Oksana and Inna (2019) recommends that “green” skills is tremendously significant for shaping the environmental culture of the upcoming generation and this prompted the revising of educational practice and produce new innovative curriculum. In addition, Hamza, et al., (2019) recommends that environmental effects which causes ecological problems owing to climate change, require continuous and immediate consideration across the globe to reserve the environment for the future generation. That is these wastes need to be managed and disposed by skilled personnel.

The findings for this study also include the ability to performance metrics. This finding is supported by Strietska-Ilina et al., (2011) that future skills demands should be identified as well as using quantitative projections of employment based on econometric models. The findings also revealed that participants stressed for the embedding hazardous materials (which involved the ability to identify and dispose hazardous materials in accordance with applicable regulations.) in to the BCT curriculum at technical colleges in Nigeria for environmental protection. This finding was supported by Manufacturing Skills Australia (2016) that environmental sustainability activities focus on the potential impact of resource usage, hazardous substances, waste and emissions on the physical environment. Also, Schröder (2016) recommended that world is presently hosting many environmentally stressing industries which resulted in increasing hazardous environmental conditions and health problems in the world. Additionally, Abdullahi et al., (2019) Said that it is evident to deduce that generic green skills are crucial in nearly any occupation to comprehend and intensify the matters and requirements of green development. In line with the forgoing Moreover, study conducted by Samaila, et al., (2020) Factors recommended for the integration of green skills in building construction trade at development in the building Nigeria intending to attain environmental sustainability. These recommendations established the fact there is need for infusing these findings into the curriculum of BCT.

4. Conclusion

The findings of this study were used to develop a conceptual model for integrating waste minimisation skills in the curriculum of BCT students for the attainment of environmental sustainability in Nigeria. Important areas waste minimisation skills were identified using five categories of respondents/participants made up of administrators,

teachers, craftsmen, instructors and professionals. The model was developed in adherence to the analysed data showing the important areas based on their level of appropriateness on waste minimisation skills elements for effective integration in to the curriculum of BCT in Nigeria. Conclusively, this conceptual model has some implications on the supervisory agency (NBTE) toward ensuring that these identified areas are embedded into the curriculum and properly imparted to students. The conceptual model will be used as a guide for effective integration of waste minimisation skills to help students offering BCT on graduation contribute immensely towards ensuring environmental sustainability in Nigeria.

5. Recommendations

In recommendation, environmental problems become a global issue as they resulted in making sustainable development unachievable in many developing countries like Nigeria. Research evidence indicated that buildings were found to be one of the contributing factors to such problems as it was declared as number one green gas emitters and consumes nearly one-third of the total wealth in the world. The government in Nigeria is using every sector (example: educational, commercial, economic, among others) towards tackling these problems. To achieve success in the fight against sustainability problems, the significant way is to foster waste minimisation skills into the curriculum of building sectors which is identified as one of the leading factors to such problem with a view to tackling these sustainability challenges.

This study used experts in building construction as participants with a view to identifying important areas of waste minimisation skills elements considered appropriate for the integration into building construction trade at Nigeria's technical colleges. This integration will give room for teaching and learning waste minimisation skills which in turn will aid Nigeria in curbing its lingering environmental challenges. Empirical findings from the 27 technical colleges in northwestern Nigeria in this study, and combining experts' suggestions and relevant literature, this study suggests that the technical colleges in Nigeria should make full use of this conceptual model as a guide to the attainment of environmental sustainability. This study provides a more detailed understanding of the roles of the waste minimisation skills in assuring sustainability by developing a conceptual model that comprised of identified important areas of waste minimization skills elements considered appropriate for effective integration in BCT at technical colleges in Nigeria. For the effective implementation of this model, the following recommendations were made:

- There is need for Federal and state Governments via NBTE to adopt and implement this model for BCT at technical colleges in Nigeria.
- The model was also recommended to policy makers and administrators in planning, organization and implementation of BCT curriculum for technical colleges in Nigeria.
- The model was recommended for implementation by BCT units of technical colleges with the supervision by school administrators for students to acquire aspects of, waste minimization skills which its impact may assist in achieving environmental sustainability.

Acknowledgement

We acknowledge the support Fundamental Research Grant Fund (Vot. No: 4F556), Universiti Teknologi Malaysia (UTMFR 21H02) and Abubakar Tafawa Balewa University Bauchi, Nigeria.

References

- Abdullahi, M. C., Yusri, B. K., Rabi, H. and Haliru, S. (2019). The Application of Generic Green Skills in Tessellation of Regular Polygons For Economic and Social Sustainability. *Asia Proceedings of Social Sciences (APSS)*. 4(3), 121-124.
- Acedo, C. (2014). Skills for inclusive and sustainable development: Perspectives from the Asia Pacific region and beyond. *Prospects*. 44(2), 137-140.
- Arasinah, K., Lazaro, M. H., Pedro, L. Y. M., Amarumi, A., Irdyanti, M. N., Che, G. C. K. and Tee, T. K. (2020). Modified Delphi Technique in Analysing Contents of Green Skills Module for Design and Technology Subject. *Journal of Technical Education and Training*. 12(1), 49-56.

- Architecture 2030 (2015). Why The Building Sector?. Retrieved online: 16th October,2016; (http://architecture2030.org/the_problem/problem_energy).
- Arif, M., Syal, M. and Yates, J. (2013). Sustainable methods for waste minimisation in construction. *Construction Innovation*. 13(3), 281-301.
- Australian Government (2012). Minimise waste on the building and construction site *CPCBC4021A*. (pp. 1-9).
- Beavers, A. S., Lounsbury, J. W., Richards, J. K., Huck, S. W., Skolits, G. J. and Esquivel, S. L. (2013). Practical considerations for using exploratory factor analysis in educational research. *Practical assessment, research & evaluation*. 18(6), 1-13.
- Beusker, E., Stoy, C. and Pollalis, S. N. (2012). Estimation model and benchmarks for heating energy consumption of schools and sport facilities in Germany. *Building and Environment*. 49(2012), 324-335.
- Bradshaw, C. (2014). Partnerships key to green skills. *Mail & Guardian*. retrieved Online December 21 2017. Retrieved
- Brown, M. and Sack, F. (2015). The development of skills for sustainability for Australian apprentices and trainees during the UN decade of education and sustainable development 2005–2014. *Proceedings of the 2015 6th International Conference of the International Network on Innovative Apprenticeship: Architectures for apprenticeship: Achieving economic and social goal*. . 1-2, 2015. Federation University, Australia., 189-193.
- Chiou, R. Y., Belu, R. and Tseng, T.-L. B. (2013). Infusion of Green Energy Manufacturing into Engineering and Technology Curricula. *Proceedings of the 2013 ASME 2013 International Mechanical Engineering Congress and Exposition*. November 15-21, 2013. San Diego, California, USA, 1-8.
- Comrey, A. L. and Lee, H. B. (2013). *A first course in factor analysis*. Psychology Press. Retrieved Online February 19 2017.
- Creswell, J. W. (2014). *Research design: Qualitative, quantitative, and mixed methods approaches*. (Fourth ed.) Thousand Oaks, California: Sage publications, Inc.
- Dania, A. A., Larsen, G. D. and Yao, R. (2013). Mainstreaming Sustainable Construction: Case Studies of An Indigenous and Multinational Firm in Nigeria. *Proceedings of the 2013 Engineering Project Organization Conference*. July 9-11, 2013. Devil's Thumb Ranch, Colorado, 1-9.
- Dobrovolskienė, N. and Tamošiūnienė, R. (2015). An index to measure sustainability of a business project in the construction industry: Lithuanian case. *Sustainability*. 8(1), 1-14.
- European Centre for the Development of Vocational Training CEDEFOP (2012). Green skills and environmental awareness in vocational education and training (doi: 10.2801/78825pp. 132). Luxembourg.
- Federal Republic of Nigeria FRN. (2015). *Nigeria 2015 Millennium Development Goals End-Point Report*. Abuja, Nigeria.
- Federal Republic of Nigeria FRN. (2015). *Nigeria 2015 Millennium Development Goals: End-Point Report:Website: www.mdgs.gov.ng*.
- Hair, J. F. (2010). Black, WC, Babin, BJ, & Anderson, RE (2010). *Multivariate data analysis*. Pearson Prentice Hall Upper Saddle River.
- Hair, J. F., Sarstedt, M., Pieper, T. M. and Ringle, C. M. (2012a). The use of partial least squares structural equation modeling in strategic management research: a review of past practices and recommendations for future applications. *Long range planning*. 45(5-6), 320-340.
- Hair, J. F., Sarstedt, M., Ringle, C. M. and Mena, J. A. (2012b). An assessment of the use of partial least squares structural equation modeling in marketing research. *Journal of the academy of marketing science*. 40(3), 414-433.
- Hair Jr, J. (2006). Black, WC, Babin, BJ Anderson, RE & Tatham, RL (2006). *Multivariate data analysis*. 6.

- Hamza, S., Musta'amal, A. H. B., Kamin, Y. B., Al-Rahmi, W. M., Kosnin, A., Saud, M. S., Suhairom, N. and Yahya, N. (2019). Assimilating Green Skills in Building Construction Programme: Crucial to Realizing Environmental Sustainability. *IEEE Access*.
- Illankoon, I. C. S., Tam, V. W. and Le, K. N. (2016). Environmental, Economic, and Social Parameters in International Green Building Rating Tools. *Journal of Professional Issues in Engineering Education and Practice*. 143(2), 05016010.
- Joseph, P. and Tretsiakova-McNally, S. (2010). Sustainable non-metallic building materials. *Sustainability*. 2(2), 400-427.
- Kassim, T. A., Simoneit, B. R. and Williamson, K. J. (2005). Recycling solid wastes as road construction materials: an environmentally sustainable approach. *Water pollution*. 5(Part F, Vol. 1), 59-181.
- Krejcie, R. V. and Morgan, D. W. (1970). Determining sample size for research activities. *Educ psychol meas*.
- Majumdar, S. (2009). Major challenges in integrating sustainable development in TVET *International Experts Meeting on Reorienting TVET Policy Towards Education for Sustainable Development Berlin, Germany* (pp. 1-15). CPSC, Manila.
- Manufacturing Skills Australia (2016). Skills for Sustainability. In Department of Education and Training (Ed.). Australia.
- Markelj, J., Kitek Kuzman, M., Grošelj, P. and Zbašnik-Senegačnik, M. (2014). A simplified method for evaluating building sustainability in the early design phase for architects. *Sustainability*. 6(12), 8775-8795.
- Napier, T. (2012). Construction waste management. *National Institute of Building Science, Available [online]. at: <http://www.wbdg.org/resources/cwmgmt.php>* Accessed. 25(05), 2013.
- National Board for Technical Education (NBTE). (2016a). *NBTE and Skilling of Young People in Nigeria: Advances and Challenges*.
- Navado-Peña, D., López-Ruiz, V.-R. and Alfaro-Navarro, J.-L. (2015). The effects of environmental and social dimensions of sustainability in response to the economic crisis of European cities. *Sustainability*. 7(7), 8255-8269.
- Oksana, K. and Inna, V. (2019). 'Green skills' of a new generation of managers and entrepreneurs as a potential of company leadership. *Advances in Social Science, Education and Humanities Research, volume 318 3rd International Conference on Social, Economic, and Academic Leadership (ICSEAL 2019)*.
- Organisation for Economic Co-operation Development OECD (2015). "Creating jobs for Tunisian youth in the green economy: Anticipating skills and developing entrepreneurship" *OECD Publishing, Paris* (DOI: <http://dx.doi.org.ezproxy.psz.utm.my/10.1787/9789264226470-9-enpp>. 211-240).
- Pavlova, M. (2011). ESD through technology education: contextualisation of approaches. *African Journal of Research in Mathematics, Science and Technology Education*. 15(3), 41-55.
- Sack, F. (2012). Gen Green: Changes in Australian apprentices' and trainees' experience of skills and sustainability from 2008 to 2011. *International Journal of Training Research*. 10(1), 30-42.
- Samaila, H., Aede, H. M. a. and Yusri, K. (2020). Integration Factors of Green Skills into Building Construction Trade Programme in Nigeria. *Journal of Technical Education and Training JTET*. 12(1), 1-10.
- Sarsvathy, T. and Ramlee, M. (2020). Development of Secondary School Students' Green Skills for Sustainable Development. *International Journal of Academic Research in Business and Social Sciences*. 10(3), 160-173.
- Schröder, T., Pavlova, M., Songthanapitak, N., & Zhiqun, Z. (2016). Editorial Issue 6: The Greening of Technical and Vocational Education and Training In: TVET@Asia, issue 6 (pp. 1-4).
- Strietska-Ilina, O., Hofman, C., Duran Haro, M. and Jeon, S. (2011). *Skills for Green Jobs: A global view. Synthesis report based on 21 country studies. Executive Summary*.

UNESCO (2012b). ESD + TVET Promoting Skills for Sustainable Development. www.unesco.org/education. UNESCO.

Williams, B., Onsmann, A. and Brown, T. (2010). Exploratory factor analysis: A five-step guide for novices. *Australasian Journal of Paramedicine*. 8(3).