



A Fuzzy Logic-Based Tuning Model in an Indoor Lighting System for Energy and Visual Comfort Management

Khairul Rijal Wagiman¹, Mohd Noor Abdullah², Mohd Faiz Md Adnan^{1*},
Imran Hussin¹, Salmiah Aziz³

¹Renewable Energy Technology (RenTECH) Focus Group, Faculty of Technical and Vocational Education, Universiti Tun Hussein Onn Malaysia (UTHM), 86400 Batu Pahat, Johor, MALAYSIA

²Green and Sustainable Energy Focus Group, Faculty of Electrical and Electronic Engineering, Universiti Tun Hussein Onn Malaysia (UTHM), 86400 Batu Pahat, Johor, MALAYSIA

³Faculty of Architecture and Ekistics, Universiti Malaysia Kelantan, Kampus Bachok, 16300 Bachok, Kelantan, MALAYSIA

*Corresponding Author

DOI: <https://doi.org/10.30880/ijie.2023.15.04.022>

Received 16 November 2022; Accepted 17 June 2023; Available online 28 August 2023

Abstract: This paper proposes a fuzzy logic-based tuning model (FLTM) for daylight-linked control of the lighting system in an office room. The proposed FLTM considered a new method of dimming levels of light-emitting diode (LED) luminaires updating process to improve the performance of the developed fuzzy logic controller (FLC) in terms of energy consumption and visual comfort metric and, at the same time, fully complies with the European Standard EN 12464-1. The artificial lighting system and daylight simulation were carried out using DIALux to model artificial lighting and daylight illuminance level matrices. The proposed FLTM was developed and simulated using MATLAB and validated and compared with other controllers, including developed FLC and artificial neural network (ANN) based control. The simulation results showed that the proposed FLTM successfully improved the performance of developed FLC in terms of a fully satisfied visual comfort set-point. It also attained higher energy savings of 2% than ANN and achieved the closest to preset visual comfort compared with other controllers. Moreover, the proposed method consumes less computational effort, and it is easy to integrate with developed FLC and daylight-linked control of the lighting system.

Keywords: Daylight-linked control, energy efficiency, fuzzy logic controller, light-emitting diode, visual comfort

1. Introduction

An artificial lighting system is crucial to provide light for daily human life, particularly at night and without daylighting exposure in the buildings. Based on recent data, in the US, the lighting system has consumed electric power up to 17% of total electricity energy in buildings [1]. However, the higher number of this consumption can be reduced. There are several strategies to reduce the electricity energy consumption of the artificial lighting system in the buildings [2] such as change conventional lamps (e.g., incandescent and fluorescent) to high energy-efficient lamps (e.g., LED) [3–6], occupancy control [7] and daylight-linked control [8–10]. The LED lamp, apart from having higher luminous efficacy and lifespan, the most important specification is easy to control than other lamps that have gained popularity [11]. In literature [8, 12, 13], the daylight-linked control strategy has been widely used due to its contribution towards higher energy savings of lighting systems in buildings.

*Corresponding author: faizma@uthm.edu.my

2023 UTHM Publisher. All rights reserved.

penerbit.uthm.edu.my/ojs/index.php/ijie

Generally, the control system has two types: conventional and intelligent. The applications of conventional controllers in interior lighting system is to control the dimming levels of luminaires, including proportional-integral (PI) [14, 15] and proportional-integral differential (PID) [16, 17]. Nevertheless, conventional controllers have several shortcomings, i.e., they are difficult to design, suffering in achieving an optimal solution, and less stability. To address these issues, a particle swarm optimization (PSO) method was proposed to find the optimal parameters of PID to improve the controller's performance [18].

Recently, most literature utilized intelligent controllers, such as artificial neural network (ANN) and fuzzy logic controller (FLC) due to their good performances. The applications of ANN controller for controlling artificial lighting systems in buildings have been successfully implemented, considering daylight [19] and without daylight [20]. The main drawbacks of ANN are it requires historical data to train the model system (time-consuming) while its performance relies on its trained data. When the data are new and out of range from the trained data as input data, the results become invalid and have higher errors. For these reasons, FLC as one of the intelligent controllers can be used to tackle these problems. FLC has been successfully utilized in building automation and control system (BACS) [21], including electric lighting system and heating, ventilation and air conditioning (HVAC). It has great performances, i.e., more robust and higher energy savings than conventional controllers, such as PID [22] as well as easy to design (fewer parameters). The hybridization of ANN and FLC, known as adaptive neuro-fuzzy inference system (ANFIS) was successfully utilized for blind control to improve the performance of a single controller [23].

The application of FLC in electric lighting systems by considering daylight have been implemented in [24–28]. Apart from a single FLC, hybrid with conventional controllers, including PI [29] and PID [30] for improving the performance of the single controller have been proposed. ANFIS was proposed by Kurian et al. [31] to improve the performance of every single intelligent controller in lighting control system.

In some cases, FLC needs to improve its performance in terms of robustness [32]. From the literature survey, they focused on the tuning of the membership functions using optimization methods, such as genetic algorithm (GA) [33], differential search algorithm (DSA) [34], and particle swarm optimization (PSO) algorithm [35]. However, this approach needs a specific optimization method and increased computational effort.

In this paper, FLC is developed to control the dimming levels of the LED lighting system in an office. Moreover, a new updating dimming levels vector of the LED luminaires method is proposed to improve the performance of the developed FLC in terms of energy consumption of the lighting system and visual comfort. The proposed method was then evaluated on its performance by comparing it to the ANN controller in terms of energy used and visual comfort metric.

The rest of this paper is organized as follows. Section 2 describes the development of the mathematical models for the daylight-linked control system. Section 3 presents the methodology of the proposed method for improving the performance of the FLC. Simulation results and discussion based on the performances of the proposed method are presented in Section 4. Finally, Section 5 presents the conclusion of the study.

2. Mathematical Models of Lighting Control System

In this section, the mathematical models, including objective function, constraints, and measurement of illuminance level and energy performance are presented.

2.1 Control Objective

The main objective of the lighting control system is to minimize energy consumption. In literature, to reduce the lighting system's electricity energy, the dimming levels of luminaires need to be minimized at the appropriate level. The dimming level of the LED luminaire is directly proportional to its output power [36–39]. For this reason, the following equation has been commonly used for the LED lighting control system.

$$\text{Min } f(d) = \sum_{k=1}^K d_k \quad (1)$$

where $f(d)$ is an objective function which is the summation of dimming levels of the LED luminaires.

2.2 Control Constraints

To achieve the objective of the control system, the following constraints should be considered.

Dimming capability of LED luminaire. This constraint refers to the luminaire specification that is provided by luminaire manufacturers. The mathematical representation is given in Equation (2). The typical values of luminaire dimming capability lower bound (D_{min}) and upper bound (D_{max}) are 0 and 1, respectively.

$$D_{min} \leq d_j \leq D_{max} \quad (2)$$

Average illuminance level (E_{avg}): The value is the average value from the measurement of illuminance levels on the working plane of the room. The minimum value (E_{avg}^{min}) is according to the standard and the maximum value (E_{avg}^{max}) is based on occupants' desired set point. The constraint can be represented in the following formula:

$$E_{avg}^{min} \leq E_{avg} \leq E_{avg}^{max} \quad (3)$$

In this paper, the value of E_{avg}^{min} is equal to maintained illuminance level (E_m) of 500 lux, which is mentioned in the European Standard EN 12464-1 [40]. Meanwhile, E_{avg}^{max} is set to 505 lux, which is 1% of E_m . By considering the illuminance level close to the E_m , the energy consumption of the electric lighting system will be reduced.

2.3 Measurement of Illuminance Level

Measurement is a crucial process to evaluate the performance of the developed FLC and the proposed method. In this study, measurement is carried out to determine E_{avg} based on a mathematical model, including an artificial light illuminance matrix for each i th lamp in the condition of one lamp is switched on and the rest of the lamps are in off condition (A_i), daylight illuminance matrix with respect to time ($B(t)$) and dimming levels of luminaires vector (d). The mathematical model of E_{avg} can be expressed in Equations (4) to (6) [41]. In this paper, the measurement grid size in accordance with the EN 12464-1 is considered.

$$E_{avg} = \text{avg}(E) \quad (4)$$

$$E = dA + B(t) \quad (5)$$

$$A = \sum_{i=1}^N A_i \quad (6)$$

2.4 Energy Performance

To evaluate the performance of the proposed method, energy consumption (EC) can be used as a metric. EC can be calculated in the following equation [41].

$$EC = \sum_{j=1}^J P_j d_j \quad (7)$$

where P_j is the total power of luminaires in the j th zone and d_j is the dimming levels of luminaires in the j th zone.

3. Proposed Fuzzy Logic-Based Tuning Model

This section presents an overview of the FLC. The development of the FLC for daylight adaptive lighting control systems is also explained. Finally, the proposed fuzzy logic-based tuning model (FLTMM) model is presented. Moreover, with the aid of the diagram, the proposed model application is explained in detail.

3.1 Overview of FLC

Fuzzy logic was first introduced by Zadeh [42] in the year 1965. The FLC concept is based on human experts to solve control systems problems and is widely used in lighting control [43, 44]. Fig. 1 shows the main components of FLC, including fuzzification, inference engine, fuzzy rules, and defuzzification.

- **Fuzzification:** The first process of the fuzzy system is to transform crisp inputs into fuzzy set. The crisp inputs are input parameters to fuzzy, and can be either from sensors (e.g., light and occupancy) or error/deviation of two or more models. This transformation is based on fuzzy linguistic variables and membership functions (MFs).

- Inference engine: Combine all MFs to produce fuzzy outputs according to fuzzy rules.
- Fuzzy rules: IF-THEN rule is used in the fuzzy system based on expert knowledge. IF condition is linked to fuzzy input, meanwhile THEN is linked to fuzzy output.
- Defuzzification: The last process of the fuzzy system to produce crisp outputs based on fuzzy outputs and degree of membership. The crisp outputs are also known as FLC outputs.

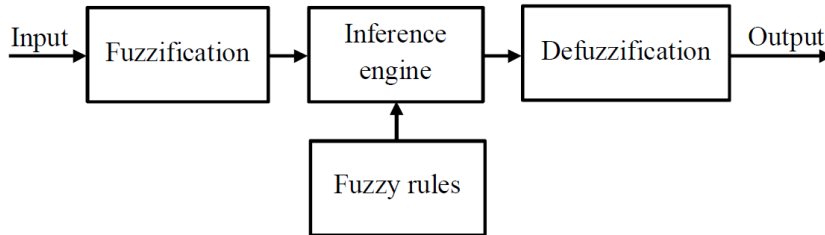

Fig. 1 - Fuzzy logic controller (FLC) diagram

3.2 Developed FLC

In this paper, the fuzzy logic toolbox in MATLAB was used to develop the FLC. Input for fuzzification is an error (er) between the illuminance value pre-set (E_m) and the illuminance value from light sensors (E_s). The fuzzification consists of five triangular membership functions, including negative (N), positive low (PL), positive medium (PM), positive high (PH), and positive very high (PVH), as presented in Fig. 2.

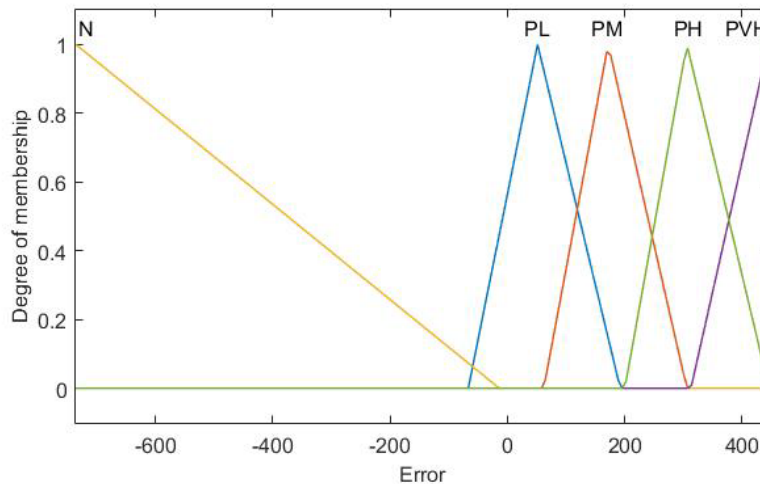

Fig. 2 - Fuzzy membership functions of input

Mamdani fuzzy inference system was used (setting in MATLAB) to produce fuzzy outputs based on five fuzzy rules, which are shown in Table 1. The fuzzy outputs are transformed to crisp output, which is dimming levels of luminaires (d_j) based on five triangular membership functions: very low (VL), low (L), medium (M), high (H), and very high (VH) are as illustrated in Fig. 3. This process is called defuzzification, where the centroid method has been used.

Table 1 - Fuzzy rules for fuzzy inference

Fuzzy rules
If (Error ==N) then Diming level=VL
If (Error ==PL) then Diming level=L
If (Error ==PM) then Diming level=M
If (Error ==PH) then Diming level=H
If (Error ==PVH) then Diming level=VH

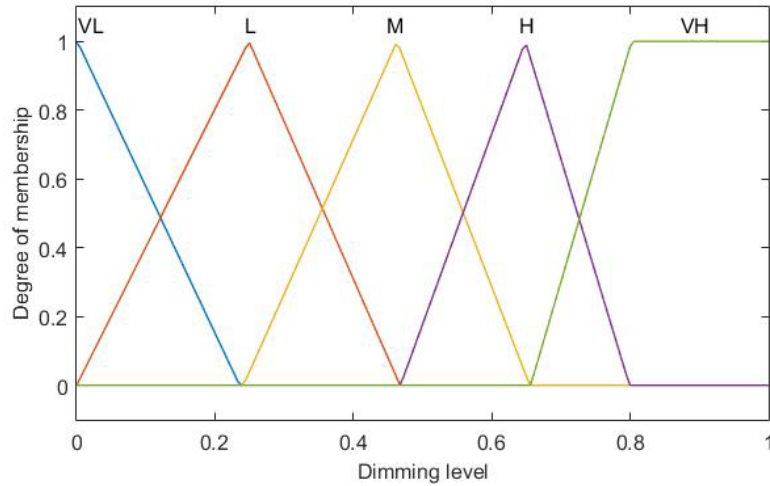

Fig. 3 - Fuzzy membership functions of output

3.3 Proposed Model

In certain cases, the performance of the FLC in terms of robustness has been debated, especially when dealing with non-linear and significant input variations [45]. In this case, the distribution of daylight illuminance (E_{day}) is the input. The variation of E_{day} is non-uniform and continuously changing with respect to time as it depends on the position of the sun path and its light intensity. For this reason, to improve the performance of the developed FLC in terms of optimized energy consumption and visual comfort that satisfies the constraint in Equation (3), a new method FLTMs with updated dimming levels of luminaires vector (d_{new}) was proposed. By updating the d_{new} , the algorithm will calculate the new E_{avg} to achieve the E_{avg} constraint in Equation (3). The mathematical formulation can be expressed as follows.

$$d_{new} = \Delta d + d_{flc} \tag{8}$$

$$\Delta d = \frac{(E_m - E_{avg}) \times 0.01}{Nz} \tag{9}$$

where d_{flc} is the dimming levels vector from FLC results, E_m is the maintained illuminance level, and Nz is a number of zones.

However, at certain times, the value of E_{avg} will be trapped at a certain value (498 lux). To overcome this problem, a constant value of Δd (0.02) is needed for selected zones, which is at a lower value of the E (measured values of the sensors) to be added with d_{flc} . This approach can be expressed mathematically as follows.

$$d(j)_{new} = 0.02 + d_{flc} \tag{10}$$

where j is j th zone of lower value of E .

The algorithm for updating the dimming levels vector is illustrated in Fig. 4 and the flow chart in Fig. 5.

```

if (lb<=Ea || Ea>=ub)           % Condition for  $E_{avg}$  (x condition)
Delta_Dn1=((Em-Ea)*0.01)/Nz     % dimming level deviation updating equation
End

if ((Em-Ea)>0 || (Em-Ea)<=2)    % condition for trapped value (y condition)
Delta(j)_Dn2=0.02              % dimming level deviation updating with constant value
End

Delta_Dnew=Delta_Dn1+ Delta(j)_Dn2  % dimming level deviation updating
Dnew= Delta_Dnew+Dflc             % dimming level updating
    
```

Fig. 4 - Proposed FLTM algorithm

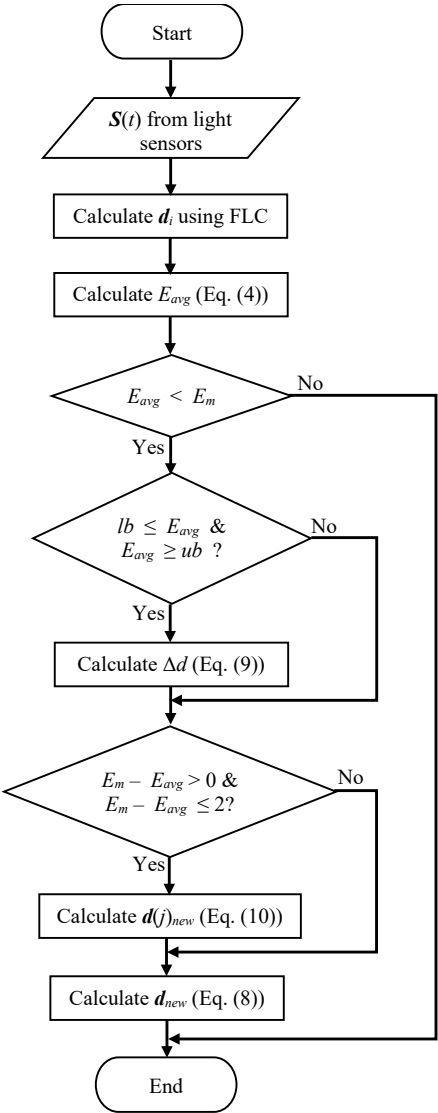

Fig. 5 - Proposed FLTM model flow chart

The application of the proposed FLTM model for daylight-linked control is shown in Fig. 6. Based on the figure, the proposed method is represented with a shaded rectangle. During daytime, initially, all artificial luminaires are switched off. The light sensors ($s(t)$) measure illuminance values, which is only from daylight ($B(t)$). The values of the sensors will be compared with the value of E_m and the difference between these two values is an error (er), which becomes the input value to the FLC. FLC provides d_{flc} , thus, this vector will be multiplied with artificial light illuminance matrix (A). Then, these results will be added with $B(t)$. The end results are called distributed illuminance levels matrix (E).

To evaluate the visual performance metric of the developed FLC, an average of E needs to be calculated. The first IF model will check the condition based on the x condition. x can be represented mathematically as in Fig. 4. If the condition is true, two actions will be considered are (1) the dimming level deviation vector (Δd) will be calculated according to Equation (5) and the signal is represented as Δd_{n1} and (2) the second IF model will be checked the condition based on y condition (refer to Figure 4). If the condition is true, the constant value of 0.02 will be taken into account for the dimming level deviation vector for selected j th zones (i.e., lower value of E) and the signal is represented as $\Delta d(j)_{n2}$. Both signals will be added to become dimming levels deviation vector (Δd_{new}). Finally, the Δd_{new} will be summed with d_{flc} and produces a new dimming level of luminaires vector (d_{new}). This process will be repeated until the lighting system is scheduled off at the end of the working hour of the room.

In this paper, the proposed FLTM model was developed and simulated by using MATLAB 2017b platform.

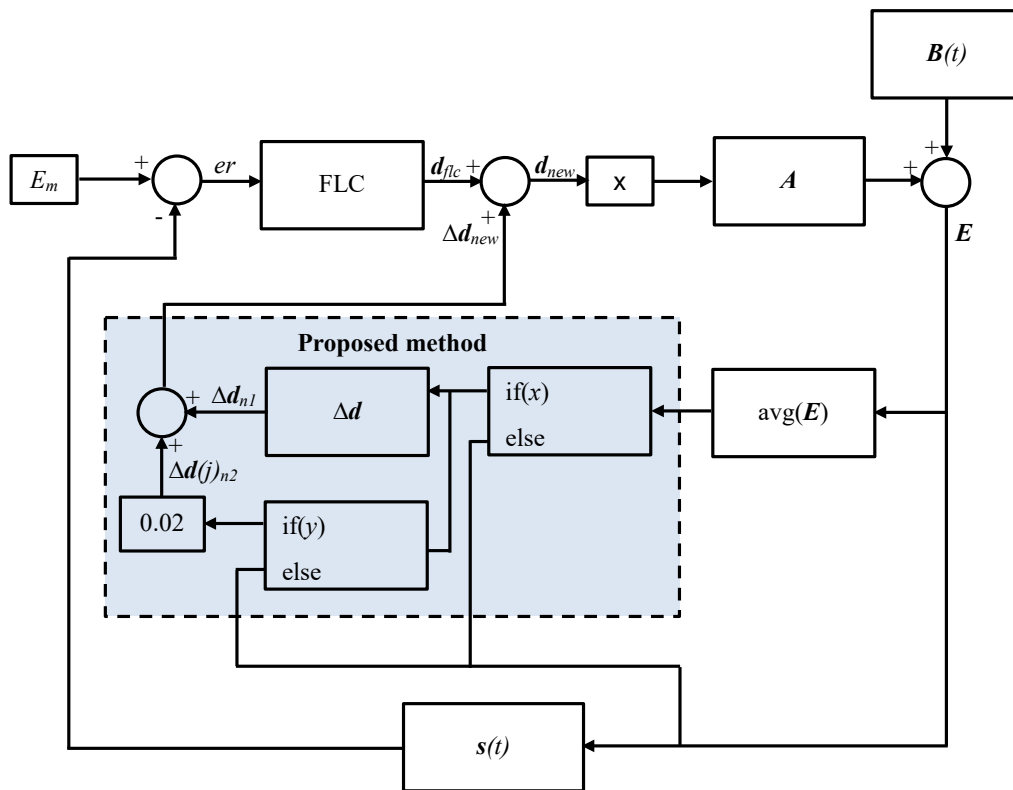

Fig. 6 - Proposed FLTM model block diagram for daylight-linked control

4. Simulation Results and Discussion

This section presents a case study, which is an office room that was used to validate and compare the performance of the proposed method. Simulation results presented also include illuminance levels for different controllers and dimming level performance. Finally, energy performance analysis results are illustrated.

4.1 Case Study

To validate and compare the performance of the proposed method, a case study in [19] was considered. The case study is an office room with a dimension of (20 × 8 × 2.7 m³). It was recessed with 35 LEDs and installed six light sensors on the ceiling. The detailed layout of the luminaires and sensors for each zone of the office room is illustrated in Fig. 7.

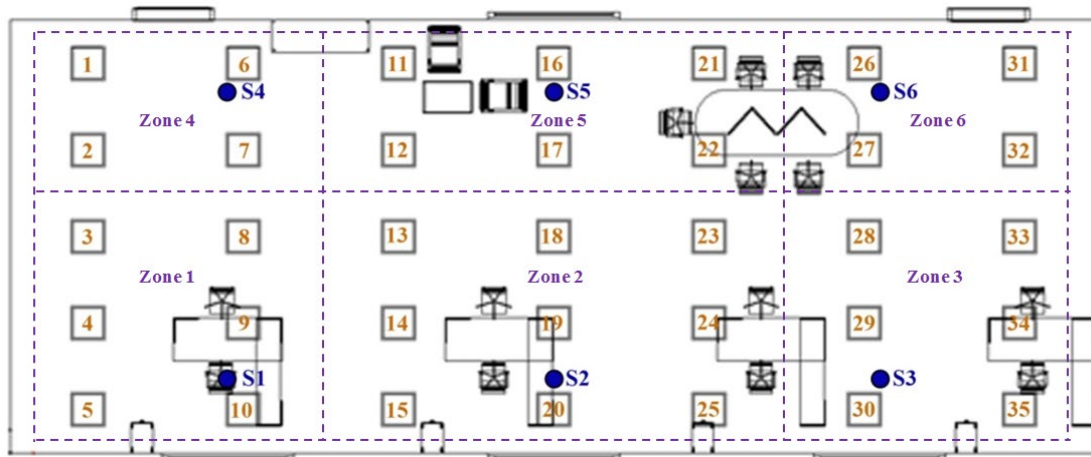

Fig. 7 - Luminaires and sensors layout for each zone of the office room [19]

4.2 Simulation Results

In this study, building modeling and lighting system simulation (i.e., artificial light and daylight) were performed using DIALux. The daylight simulation under a clear sky setting was considered between 8.00 a.m. and 5.00 p.m. with a one-hour interval on 5th October 2017. To fairly compare the performance of the proposed FLTM with the ANN controller [19], the parameters such as sky condition (clear), test periods (9 h), and date (5th October 2017) were maintained to be the same.

Fig. 7 shows the comparison results of average illuminance levels for different controllers, including ANN, FLC, and FLTM. It can be seen in Fig. 7, FLC results at times 8:00, 9:00, and 17:00 did not achieve a minimum illuminance level (i.e., 500 lux). The rest of the time did achieve the minimum illuminance level. However, at times 10:00, 11:00, 14:00, 15:00, and 16:00, the results did not satisfy the upper bound of the constraint, which is shown in equation (3). Meanwhile, ANN results [19] showed that all the times within the stipulated period achieved the minimum illuminance level. However, the only time it did not satisfy the upper bound was at time 8:00. For the proposed FLTM, it was shown that all the time was fully satisfied with the illuminance level bounds. Based on this analysis, the proposed FLTM showed superior performance compared to other controllers in terms of satisfying the average illuminance level constraint.

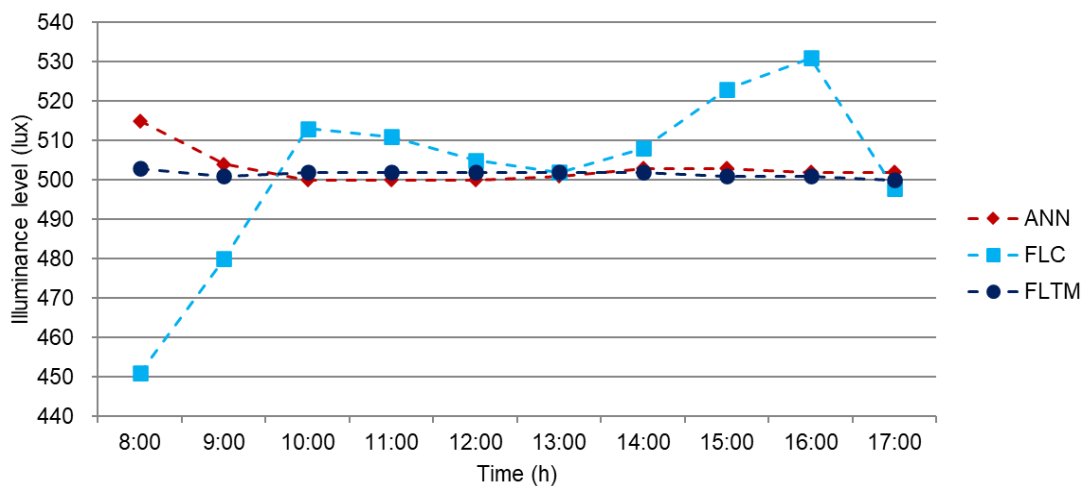

Fig. 8 - Comparison results of average illuminance level for different controllers

According to Equation (1), the main objective of the lighting control system is to minimize the summation of dimming levels of LED luminaires. The comparison results of dimming levels of LED luminaires based on measured illuminance of sensors under different controllers are presented in Table 2. It can be seen in Table 2, the proposed FLTM showed the best performance among controllers for most of the time in terms of providing the lowest summation of dimming levels of LED luminaires and, at the same time satisfied the visual performance metric. The significant difference in the summation of dimming levels between the proposed FLTM and ANN was at 8.00 a.m. with 0.246. At the time of 13:00, FLC and the proposed FLTM has the same value of dimming levels summation due to the value of E_{avg} satisfying its constraint, thus the proposed method is not required. Meanwhile, at the times of 10:00 to 12:00, ANN recorded the lowest summation of dimming levels compared to the other controllers.

Table 2 - Comparison results of dimming levels of LED luminaires under different controllers

Time	Measured illuminance of sensors						C ^a	Dimming levels of LED luminaires						
	s ₁	s ₂	s ₃	s ₄	s ₅	s ₆		d ₁	d ₂	d ₃	d ₄	d ₅	d ₆	Sum ^b
8:00	440	515	399	63	465	117	ANN	0.390	0.340	0.470	0.990	0.400	0.800	3.390
							FLC	0.239	0.237	0.305	0.862	0.238	0.771	2.653
							FLTM	0.321	0.319	0.387	0.944	0.320	0.853	3.144
9:00	687	822	608	93	910	147	ANN	0.140	0.030	0.060	0.990	0.300	0.760	2.280
							FLC	0.101	0.092	0.090	0.818	0.105	0.719	1.925
							FLTM	0.134	0.124	0.123	0.850	0.138	0.752	2.120
10:00	913	976	692	100	923	141	ANN	0.000	0.000	0.050	0.980	0.000	0.760	1.790
							FLC	0.086	0.082	0.101	0.804	0.086	0.727	1.887
							FLTM	0.065	0.061	0.080	0.803	0.065	0.726	1.801
11:00	916	1036	719	101	921	127	ANN	0.000	0.000	0.040	0.970	0.000	0.780	1.790
							FLC	0.088	0.080	0.099	0.804	0.086	0.750	1.907
							FLTM	0.070	0.061	0.080	0.806	0.068	0.751	1.836
12:00	919	1068	739	96	936	115	ANN	0.000	0.000	0.040	0.980	0.000	0.800	1.820
							FLC	0.086	0.094	0.097	0.807	0.088	0.768	1.940
							FLTM	0.078	0.085	0.088	0.818	0.079	0.779	1.928
13:00	971	1105	771	108	859	109	ANN	0.000	0.084	0.071	0.953	0.048	0.878	2.033
							FLC	0.083	0.095	0.095	0.804	0.090	0.777	1.944
							FLTM	0.083	0.095	0.095	0.804	0.090	0.777	1.944
14:00	1053	778	819	108	850	109	ANN	0.157	0.006	0.060	0.994	0.000	0.818	2.035
							FLC	0.079	0.076	0.091	0.792	0.094	0.777	1.909
							FLTM	0.065	0.062	0.078	0.799	0.081	0.784	1.868
15:00	1141	1195	863	122	824	112	ANN	0.014	0.000	0.027	0.965	0.008	0.878	1.892
							FLC	0.076	0.075	0.088	0.774	0.093	0.772	1.879
							FLTM	0.037	0.036	0.049	0.755	0.054	0.753	1.685
16:00	1216	1175	859	135	771	113	ANN	0.006	0.000	0.005	0.902	0.000	0.862	1.774
							FLC	0.075	0.075	0.088	0.754	0.097	0.771	1.861
							FLTM	0.023	0.023	0.036	0.722	0.045	0.739	1.587
17:00	1014	996	735	136	635	101	ANN	0.019	0.012	0.073	0.916	0.191	0.941	2.151
							FLC	0.080	0.081	0.096	0.751	0.105	0.787	1.900
							FLTM	0.084	0.084	0.100	0.755	0.109	0.791	1.924

Note:

^a Types of controllers

^b Summation of the dimming levels of LED luminaires

4.3 Energy Performance Analysis Results

In this study, the energy consumption (EC) of the proposed FLTM method was compared to ANN [19]. The comparison results of EC for ANN and FLTM are depicted in Fig. 8. Based on the figure, the highest (0.6 kWh) and the lowest (0.25 kWh) EC were contributed by ANN at times 8:00 and 10:00, respectively. Whereas most of the time, the proposed FLTM contributed lower EC than ANN, for example at times 8:00 (0.55 kWh) and times 17:00 (0.29 kWh). From this analysis, the proposed FLTM achieved higher energy savings of 2% than ANN.

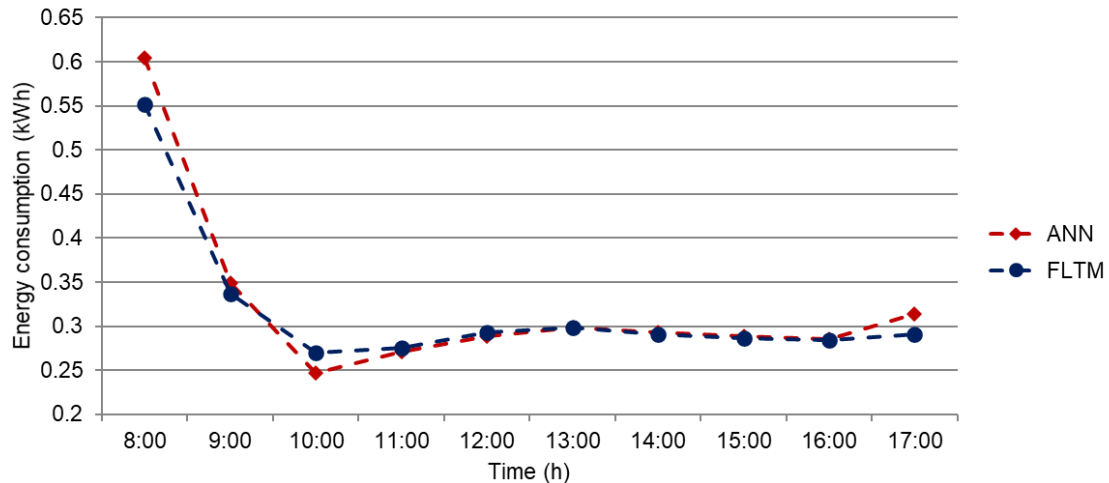

Fig. 9 - Comparison results of energy consumption for different controllers

5. Conclusion

In this paper, FLC is developed to control the dimming levels of LED luminaires by considering daylight for an office room. Due to the lower performance of the developed FLC and the targeted illuminance levels not achieved as well as because of higher energy consumption, the FLTM based on a new dimming levels updating method was proposed. The proposed FLTM was compared to other methods, including developed FLC and ANN to evaluate the performance. From the simulation results, the proposed FLTM showed great performance compared with other methods in terms of fully satisfied illuminance level constraint and attain higher energy savings of 2% than ANN. Moreover, the proposed method is also easy to integrate with existing FLC and it utilized less computational time compared to other methods, such as using optimization techniques for tuning the fuzzy system parameters.

Acknowledgments

This work is funded by the Universiti Tun Hussein Onn Malaysia (UTHM) under TIER 1 Research Grant, Vot no. Q155.

References

- [1] EIA. (2012). Commercial Buildings Energy Consumption Survey.
- [2] Dubois, M.-C., Bisegna, F., Gentile, N., Knoop, M., Matusiak, B., Osterhaus, W., & Tetri, E. (2015). Retrofitting the Electric Lighting and Daylighting Systems to Reduce Energy Use in Buildings: A Literature Review. *Energy Research Journal*, 6(1), 25–41. <https://doi.org/10.3844/erjsp.2015.25.41>
- [3] Wagiman, K. R., & Abdullah, M. N. (2018). Lighting System Design According to Different Standards in Office Building: A Technical and Economic Evaluations. *Journal of Physics: Conference Series*, 1049. <https://doi.org/10.1088/1742-6596/1049/1/012010>
- [4] Ganandran, G. S. B., Mahlia, T. M. I., Ong, H. C., Rismanchi, B., & Chong, W. T. (2014). Cost-Benefit Analysis and Emission Reduction of Energy Efficient Lighting at the Universiti Tenaga Nasional. *The Scientific World Journal*, 2014, 1–12. <https://doi.org/10.1155/2014/745894>
- [5] Halim, M. F. M. A., Azlan, U. A.-A., Harun, M. H., Annuar, K. A. M., M, M., Johari, S. H., ... Hushim, M. F. (2017). Lighting Retrofit Scheme Economic Evaluation. *Indonesian Journal of Electrical Engineering and Computer Science*, 5(3), 496–501.
- [6] Gan, C. K., Sapar, A. F., Mun, Y. C., & Chong, K. E. (2013). Techno-economic analysis of LED lighting: A case study in UTeM's faculty building. *Procedia Engineering*, 53, 208–216. <https://doi.org/10.1016/j.proeng.2013.02.028>
- [7] Zou, H., Zhou, Y., Jiang, H., Chien, S.-C., Xie, L., & Spanos, C. J. (2018). WinLight: A WiFi-based occupancy-driven lighting control system for smart building. *Energy and Buildings*, 158, 924–938. <https://doi.org/https://doi.org/10.1016/j.enbuild.2017.09.001>
- [8] Boscarino, G., & Moallem, M. (2016). Daylighting Control and Simulation for LED-Based Energy-Efficient Lighting Systems. *IEEE Transactions on Industrial Informatics*. <https://doi.org/10.1109/TII.2015.2509423>
- [9] Xiong, J., & Tzempelikos, A. (2016). Model-based shading and lighting controls considering visual comfort and energy use. *Solar Energy*, 134, 416–428. <https://doi.org/http://dx.doi.org/10.1016/j.solener.2016.04.026>
- [10] Özçelik, M. A. (2017). The design and implementation of PV-based intelligent distributed sensor LED lighting

- in daylight exposed room environment. *Sustainable Computing: Informatics and Systems*, 13, 61–69. <https://doi.org/http://dx.doi.org/10.1016/j.suscom.2017.01.001>
- [11] Doulos, L. T., Tsangrassoulis, A., Kontaxis, P. A., Kontadakis, A., & Topalis, F. V. (2017). Harvesting daylight with LED or T5 fluorescent lamps? The role of dimming. *Energy and Buildings*, 140, 336–347. <https://doi.org/10.1016/j.enbuild.2017.02.013>
- [12] Kumar, R. (2015). New algorithms for daylight harvesting in a private office. 2015 18th International Conference on Information Fusion (Fusion).
- [13] Chew, I., Kalavally, V., Oo, N. W., & Parkkinen, J. (2016). Design of an energy-saving controller for an intelligent LED lighting system. *Energy and Buildings*, 120, 1–9. <https://doi.org/http://dx.doi.org/10.1016/j.enbuild.2016.03.041>
- [14] van de Meughevel, N., Pandharipande, A., Caicedo, D., & van den Hof, P. P. J. (2014). Distributed lighting control with daylight and occupancy adaptation. *Energy and Buildings*, 75, 321–329. <https://doi.org/http://dx.doi.org/10.1016/j.enbuild.2014.02.016>
- [15] Peruffo, A., Pandharipande, A., Caicedo, D., & Schenato, L. (2015). Lighting control with distributed wireless sensing and actuation for daylight and occupancy adaptation. *Energy and Buildings*, 97, 13–20. <https://doi.org/10.1016/j.enbuild.2015.03.049>
- [16] Soori, P. K., & Vishwas, M. (2013). Lighting control strategy for energy efficient office lighting system design. *Energy and Buildings*, 66, 329–337. <https://doi.org/https://doi.org/10.1016/j.enbuild.2013.07.039>
- [17] Juchem, J., Lefebvre, S., Mac, T. T., & Ionescu, C. M. (2018). An Analysis of Dynamic Lighting Control in Landscape Offices. *IFAC-PapersOnLine*, 51(4), 232–237. <https://doi.org/https://doi.org/10.1016/j.ifacol.2018.06.071>
- [18] Copot, C., Thi, T. Mac, & Ionescu, C. (2018). PID based Particle Swarm Optimization in Offices Light Control. *IFAC-PapersOnLine*, 51(4), 382–387. <https://doi.org/https://doi.org/10.1016/j.ifacol.2018.06.096>
- [19] Wagiman, K. R., & Abdullah, M. N. (2018). Intelligent Lighting Control System for Energy Savings in Office Building. *Indonesian Journal of Electrical Engineering & Computer Science*, 11(1), 195–202. <https://doi.org/10.11591/ijeecs.v11.i1.pp195-202>
- [20] Wang, Z., & Tan, Y. K. (2013). Illumination control of LED systems based on neural network model and energy optimization algorithm. *Energy and Buildings*, 62, 514–521. <https://doi.org/https://doi.org/10.1016/j.enbuild.2013.03.029>
- [21] Omarov, B., & Altayeva, A. (2018). Design of a multiagent-based smart microgrid system for building energy and comfort management. *Turkish Journal of Electrical Engineering & Computer Sciences*, 26, 2714 – 2725.
- [22] Ahmad, M. W., Mourshed, M., Yuce, B., & Rezgui, Y. (2016). Computational intelligence techniques for HVAC systems: A review. *Building Simulation*, 9(4), 359–398. <https://doi.org/10.1007/s12273-016-0285-4>
- [23] Gomathi Bhavani, R., & Khan, M. A. (2009). An intelligent simulation model for blind position control in daylighting schemes in buildings. *Building Simulation*, 2(4), 253. <https://doi.org/10.1007/s12273-009-9122-3>
- [24] Cziker, A., Chindris, M., & Miron, A. (2008). Fuzzy controller for a shaded daylighting system. In 2008 11th International Conference on Optimization of Electrical and Electronic Equipment (pp. 203–208). <https://doi.org/10.1109/OPTIM.2008.4602522>
- [25] Quyen, H. A., Le, T. T. T., Le, T. N., & Pham, T. M. T. (2014). Combining the Daylight and Artificial Light Based on Fuzzy Logic. In I. Zelinka, V. H. Duy, & J. Cha (Eds.), *AETA 2013: Recent Advances in Electrical Engineering and Related Sciences* (pp. 93–102). Berlin, Heidelberg: Springer Berlin Heidelberg.
- [26] Cziker, A., Chindris, M., & Miron, A. (2007). Fuzzy controller for indoor lighting system with daylighting contribution. In 5th international conference on electrical and electronics engineering (ELECO2007). Bursa, Turkey.
- [27] Cziker, A., Chindris, M., & Miron, A. (2007). Implementation of Fuzzy Logic in Daylighting Control. In 2007 11th International Conference on Intelligent Engineering Systems (pp. 195–200). <https://doi.org/10.1109/INES.2007.4283697>
- [28] Ghadi, Y. Y., Rasul, M. G., & Khan, M. M. K. (2017). The Integration of Day Light with Advance Fuzzy Based Controllers for Institutional Buildings in the Region of Central Queensland, Australia. *Energy Procedia*, 105, 2429–2437. <https://doi.org/https://doi.org/10.1016/j.egypro.2017.03.698>
- [29] Liu, J., Zhang, W., Chu, X., & Liu, Y. (2016). Fuzzy logic controller for energy savings in a smart LED lighting system considering lighting comfort and daylight. *Energy and Buildings*, 127, 95–104. <https://doi.org/http://dx.doi.org/10.1016/j.enbuild.2016.05.066>
- [30] Cimini, G., Freddi, A., Ippoliti, G., Monteriù, A., & Pirro, M. (2015). A Smart Lighting System for Visual Comfort and Energy Savings in Industrial and Domestic Use. *Electric Power Components and Systems*, 43(15), 1696–1706. <https://doi.org/10.1080/15325008.2015.1057777>
- [31] Kurian, C. P., Kuriachan, S., Bhat, J., & Aithal, R. S. (2005). An adaptive neuro-fuzzy model for the prediction and control of light in integrated lighting schemes. *Lighting Research & Technology*, 37(4), 343–351. <https://doi.org/10.1191/1365782805li150oa>
- [32] Chandrasekaran, S., Durairaj, S., & Padmavathi, S. (2021). A Performance Improvement of the Fuzzy

- Controller-Based Multi-Level Inverter-Fed Three-Phase Induction Motor with Enhanced Time and Speed of Response. *Journal of Electrical Engineering & Technology*, 16(2), 1131–1141. <https://doi.org/10.1007/s42835-020-00649-6>
- [33] Alcalá, R., Alcalá-Fdez, J., Gacto, M. J., & Herrera, F. (2007). Improving fuzzy logic controllers obtained by experts: a case study in HVAC systems. *Applied Intelligence*, 31(1), 15. <https://doi.org/10.1007/s10489-007-0107-6>
- [34] Mutlag, A. H., Shareef, H., Mohamed, A., Hannan, M. A., & Ali, J. A. (2014). An Improved Fuzzy Logic Controller Design for PV Inverters Utilizing Differential Search Optimization. *International Journal of Photoenergy*, 2014, 1–14.
- [35] Letting, L. K., Munda, J. L., & Hamam, Y. (2012). Optimization of a fuzzy logic controller for PV grid inverter control using S-function based PSO. *Solar Energy*, 86(6), 1689–1700. <https://doi.org/https://doi.org/10.1016/j.solener.2012.03.018>
- [36] Rossi, M., Pandharipande, A., Caicedo, D., Schenato, L., & Cenedese, A. (2015). Personal lighting control with occupancy and daylight adaptation. *Energy and Buildings*, 105, 263–272. <https://doi.org/10.1016/j.enbuild.2015.07.059>
- [37] Caicedo, D., & Pandharipande, A. (2013). Distributed Illumination Control With Local Sensing and Actuation in Networked Lighting Systems. *IEEE Sensors Journal*. <https://doi.org/10.1109/JSEN.2012.2228850>
- [38] Caicedo, D., & Pandharipande, A. (2015). Daylight and occupancy adaptive lighting control system: An iterative optimization approach. *Lighting Research & Technology*, 48(6), 661–675. <https://doi.org/10.1177/1477153515587148>
- [39] Yun, J., & Ryeom, J. (2020). Dimming Correction Scheme considering Luminous Characteristics of R, G, B LEDs in Visible Light Communication. *Journal of Electrical Engineering & Technology*, 15(4), 1759–1768. <https://doi.org/10.1007/s42835-020-00454-1>
- [40] European Committee for Standardization. (2011). *European Standard EN 12464-1: Light and lighting - Lighting of work places - Part 1: Indoor work places*.
- [41] Wagiman, K. R., Abdullah, M. N., Hassan, M. Y., & Mohammad Radzi, N. H. (2021). A new metric for optimal visual comfort and energy efficiency of building lighting system considering daylight using multi-objective particle swarm optimization. *Journal of Building Engineering*, 43, 102525. <https://doi.org/https://doi.org/10.1016/j.jobe.2021.102525>
- [42] Zadeh, L. A. (1965). Fuzzy sets. *Information and Control*, 8(3), 338–353. [https://doi.org/https://doi.org/10.1016/S0019-9958\(65\)90241-X](https://doi.org/https://doi.org/10.1016/S0019-9958(65)90241-X)
- [43] Panchalingam, R., & Chan, K. C. (2019). A state-of-the-art review on artificial intelligence for Smart Buildings. *Intelligent Buildings International*, 1–24. <https://doi.org/10.1080/17508975.2019.1613219>
- [44] Ding, X., Yu, J., & Si, Y. (2018). Office light control moving toward automation and humanization: a literature review. *Intelligent Buildings International*, 1–32. <https://doi.org/10.1080/17508975.2018.1555087>
- [45] Ghiaus, C. (2001). Fuzzy model and control of a fan-coil. *Energy and Buildings*, 33(6), 545–551. [https://doi.org/https://doi.org/10.1016/S0378-7788\(00\)00097-9](https://doi.org/https://doi.org/10.1016/S0378-7788(00)00097-9)