

# Design of an Automated Hybrid System for Aquaculture and Agriculture Process and Its Performance Analysis

Herman Wahid<sup>1,\*</sup>, Ahmad Fakri Mohd Noor<sup>2</sup>, Dirman Hanafi Burhanuddin<sup>3</sup>,  
Rozaimi Ghazali<sup>4</sup>

<sup>1</sup>PROTOM-i Research Group, Faculty of Electrical Engineering, Universiti Teknologi Malaysia, Skudai, Malaysia.

<sup>2</sup>Faculty of Electrical Engineering, Universiti Teknologi Malaysia, Skudai, Malaysia.

<sup>3</sup>Faculty of Electrical and Electronic Engineering, Universiti Tuen Hussien Onn Malaysia, Johor, Malaysia.

<sup>4</sup>Faculty of Electrical Engineering, Universiti Teknikal Malaysia Melaka (UTeM), Melaka, Malaysia.

**Abstract:** Fish farming (aquaculture) has become one of important food resources in human life. With the high demand of fish in the market, the fish farmer is forced to find the alternatives way to increase the fish farming production. The use of cement pond, land pond, canvas pond etc. will cause some obstacles to the fish. The ammonia is one of the waste produced from the fish manure and the feed waste. The increasing of ammonia inside the aquaculture system will lead to fish life interruption or death. Nevertheless, ammonia that is converted to nitrate has good potential for the growths of plants in agriculture system. This study aims to provide the solution of the stated problems by pumping the ammonia-contained water to the agriculture by applying an automation system. The water which is going through to the plants can isolate the ammonia and filter the good quality water back to the fish pond. To reduce the system cost, pH sensor is used as an alternative way to represent the ammonia level in the aquaculture system. Besides, the system will be operated in a power-saving mode where the water pump will not be operated if the amount of ammonia does not exceed the limit. Hence, water pump will operate twice a day by scheduling it using a microcontroller in order to ensure the plant will receive the suitable amount of ammonia water for growing. Besides, the development of auto fish feeder is another added feature for this system.

**Keywords:** aquaculture, ammonia, nitrate, agriculture, pH sensor

## 1. Introduction

In the natural environment, fish are harvested in cages and placed in lakes, land ponds, rivers or oceans. In the fish farming system, there are many types of system that has been designed to grow the fish. The system includes circular tank, rectangular raceway tanks, net cages, cement ponds, canvas ponds.

Nowadays, the market demand for fish is too high and it is difficult for the supplier to meet this demand. To solve this issue there are several outdoor fish farming methods such as cement ponds, canvas ponds, and poly tanker ponds were developed. Unfortunately, they also have several of disadvantages especially for the water quality due to the recycling process. The quality of water is important for the growth of fish such as the pH level and amount of ammonia in the water. The increasing of pH level and amount of ammonia can cause lead to disease and finally will kill the fish. This pH level and amount of ammonia must be reduced or maintained at safety level by implementing the recycling system.

On the other hand, the ammonia has a good potential for the agriculture system. The plants will healthily growth by supplying nitrates which have been produced by the combination of alkalinity and ammonia. Therefore, in this study, a smart aquaculture system with linked to an agriculture system will be developed to solve the issue. The system will operate automatically which gives benefit to the agriculture system. The main concept is

water from a fish pond or tanker is filtering out the waste water (fish manure) without using the regular filter (i.e. which involves high maintenance cost). All waste from fish manure will be filtered and go through the agriculture system and finally released to the fish pond or water tanker. The system will detect the amount of ammonia (from the fish pond) by using a sensor. All the system parameter will be monitored by the microcontroller.

This paper is organised as follows: in Section 2, a review of pervious works is addressed. Section 3 describes the methodology to develop the proposed system. In the last two sections, simulation results using Matlab Neural Network Toolbox are described in graphs and tables, and followed by the conclusion in the last section.

## 2. Background Studies

The Aquaculture and Agriculture are important in the human life activities. Nowadays, there are some farming structures that are available such as ponds, tank, cage, and canvas. In Malaysia, agriculture activities are mostly using a manual system process (open loop system) as shown in Fig. 1. In the fish farming they are using the water filtering system which has produced the uncontaminated water that goes through to the ponds or tanker.

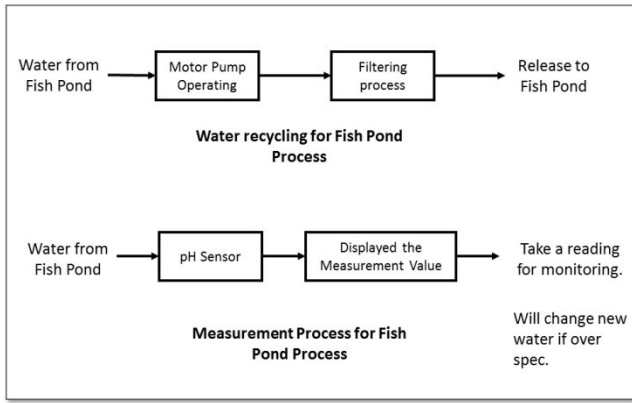

Fig.1 Typical process for fish pond

In 1997, Rakocy *et al.* from University of the Virgin Islands Agricultural had carried a research regarding the implementation of aquaponics system for the intensive production of tilapia and hydroponic vegetables for the commercial production trial. They suggest using the raft hydroponic for the most suitable technique for culturing vegetables with fish in outdoor systems. In other suggestion, a large plant growing area required to the fish culture component. By uptake the ammonia and nitrification on the tank surface, the hydroponic components make a role maintain a good water quality [1].

The Aquaponic systems mean the combination between aquaculture and hydroponics system in a closed recirculating system. In the other words mean the recirculating aquaculture systems incorporate the production of the plant without soil. To raise the largest quantities of fish in a relatively small volume of water and to treating the water, the recirculating system was designed. The system is removing the toxicity waste product from the water and reusing it gain. Fish release wastes nitrogen, in the form of ammonia, directly into the water through their gills. Ammonia transform to nitrite and then to nitrate by bacteria. Ammonia and nitrite are relatively harmless and is the preferred form of nitrogen for growing higher plants such as fruiting vegetables, but it is toxic to fish life [2].

Either unionized ammonia (NH<sub>3</sub>) or the ammonium ion (NH<sub>4</sub><sup>+</sup>) inside of water, sum of both is a technique used to measure the ammonia. The value is known as “accumulate of ammonia” or in other words called “ammonia” [3]. The relative proportion of both (NH<sub>3</sub> & NH<sub>4</sub><sup>+</sup>) presents in water mainly affected by pH as shown in Figure 2. When the pH value is high the un-ionized ammonia is toxic form and predominates. For the lower pH value, the ammonium ion is relatively non-toxic and predominates. In general, when the value of pH is less than 8.0 the ammonia is in the toxic inside water is less than 10% [4]. In the other information, pH value can be representative to detect the ammonia level. pH 7.5 or higher is the boundary of the ammonia level [5].

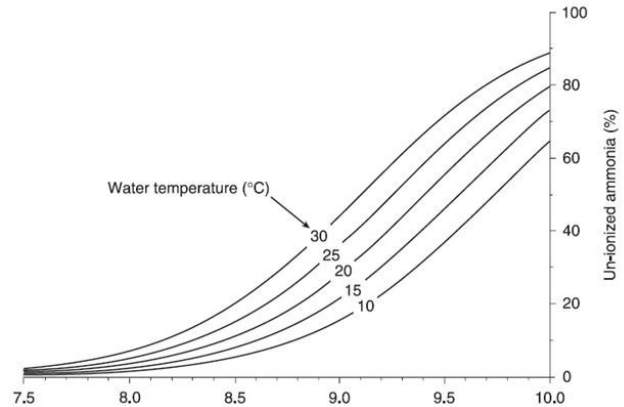

Fig. 2 The percentage of toxic and coloration between pH and temperature for the increases of un-ionized ammonia [4]

Table 1 shows the guideline for water quality where the total of ammonia guidelines related with pH (6.0-10.0) and effect by temperature (0-30 °C). 0.019 mg•L<sup>-1</sup> is the un-ionized ammonia guideline presented by Emerson *et al.* (1975) and EPA (1998). This guideline recommended the total of ammonia represented to the pH and effect by temperature [6].

Table 1 The guidelines of water quality for the protection of aquatic life (Total of Ammonia, Mg•L<sup>-1</sup> NH<sub>3</sub>) [6]

Temp (°C)	pH							
	6.0	6.5	7.0	7.5	8.0	8.5	9.0	10
0	231	73.0	23.1	7.32	2.33	0.749	0.250	0.042
5	153	48.3	15.3	4.84	1.54	0.502	0.172	0.034
10	102	32.4	10.3	3.26	1.04	0.343	0.121	0.029
15	69.7	22.0	6.98	2.22	0.715	0.239	0.089	0.026
20	48.0	15.2	4.82	1.54	0.499	0.171	0.067	0.024
25	33.5	10.6	3.37	1.08	0.354	0.125	0.053	0.022
30	23.7	7.50	2.39	0.767	0.256	0.094	0.043	0.021

The ammonia is the toxicity for fish habitual or aquaculture system. When ammonia accumulates meet the toxic level, fish difficult to extract the energy from the feed. The main source of ammonia in fish pond coming from fish manure and fish feed. The limit of the ammonia level is 0.5 mg/l [7].

In the aquaculture system, the most important parameters to be monitored and controlled are related to water quality. The recommended parameters to be monitored and controlled are temperatures, dissolved oxygen (DO), pH and water flow [8]. The system needs to monitor directly on a continuous basis since they tend to change rapidly and have a significant adverse effect on the system. Some of the equipment due to the cost, if does not attempt to control these parameters such as ammonia sensor. The ammonia changes slowly and tends to stay in range if the proper flow rate is maintained.

The automatic siphons mean the cycling of flood-and-drain in ebb-and-flow aquaponic systems can be controlled by the electronic devices, which control the activity of water pumps, or non-mechanical equipment. It

is also called the “autosiphon” where the water level can be started and stopped operates by their own. They are many types of the autosiphon, one of the simplest and most reliable is called the bell siphon. In Fig. 3, there are three types commonly used for the ebb-and-flow aquaponic system [9].



Fig. 3 Blackcinder (left), Pea Gravel (center) and right Clay balls (right) typically used in aquaponic system [9]

### 3. Methodology of System Design

This section discusses on methodology and process flow for this study including equipment and software that will be used in the entire work process.

This system is divided into three components that are input, process and output as shown in Fig. 4. For the input part, the pH electrode, temperature sensor, and water level sensor used to measure the parameter in the water respectively. The pH sensor and temperature sensor will send the analogue signal to the microcontroller input and the water level sensor sends the digital signal into the microcontroller input. This water level used to capture the signal for the level of water either in low or high volumes of water. Finally at the output part, LCD Display will display the information such as temperature, pH value and the current operation of the microcontroller. When the pH value out of the range (i.e. the amount of ammonia is too high), the water pump will operate. This water pump will pump the water into the fish pond and transfer to agriculture system. If the water level detected too low, water valve will operate to increase the level of water inside pond.

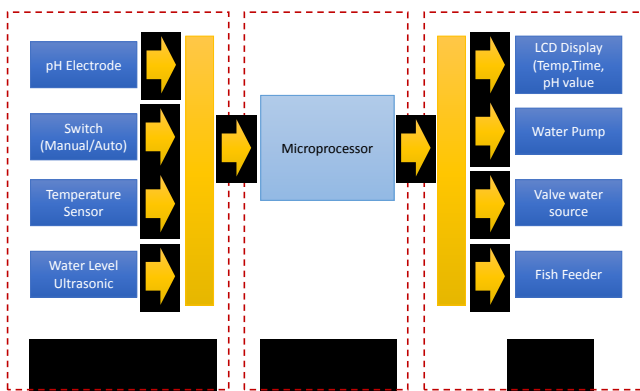

Fig. 4 Overall block Diagram of the system

In Fig. 5, we can see the clear conceptual of the proposed hybrid system, while Fig. 6 shows the overall feedback control system. The inputs of this feedback control system are water level set point and pH set point

and process by three controllers. Motor pump, water source and fish feed feeder are the actuator on this system. The plant is represented by agriculture system and aquaculture system.

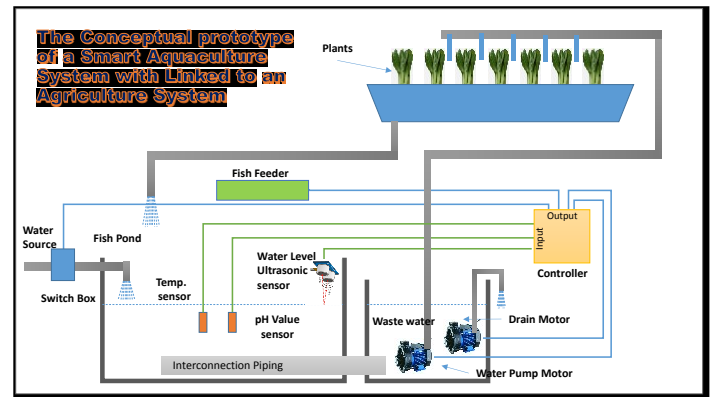

Fig. 5 Conceptual diagram of the system

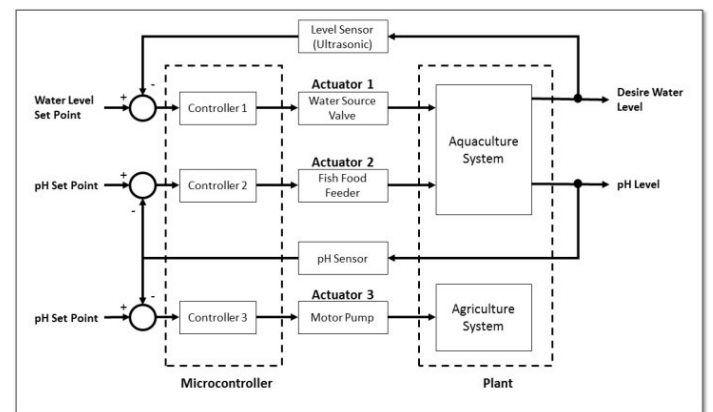

Fig. 6 Overall feedback control system

There are several types of equipment involved to ensure the smooth operation of the system. The main component of this system is the pH electrode sensor and microcontroller. The pH sensor will measure pH value inside water and transfer into microcontroller in an analogue signal. The operational amplifier component is required during development stage.

As the price of the ammonia sensor is comparatively expensive, the sensor will be replaced by the pH sensor. The amount of the ammonia will increase when the pH value is more than 7.5pH. If range more than 7.5, it means that the ammonia level is too high. In this case, we will do the random sampling for the water by verifying the colour of water. If the amount of ammonia is increasing, the pH value will be set for every change of the ammonia value.

For the other parts, the water level sensor, LCD display, water pump, fish tanker, and water valve will be implemented in this research. To develop the program for the microcontroller, Arduino IDE programming is required. The software will be used to design the step of the process flow.

### 3.1 pH Sensor

The pH sensor that will be used for this study is SEN0169. The measurement range is 0 pH to 14 pH and the accuracy of this sensor is  $\pm 0.1$  pH. Fig. 7 shows that the pH sensor and pH meter module.



Fig. 7 pH sensor electrode and pH meter Module

The calibration for the pH electrode was done as shown in Fig. 8 by using the pH buffer powder. The calibration is really important for this study in order to ensure that the measurement data is accurate.



Fig. 8 Calibration pH sensor by using pH buffer powder

The circuit diagram for the pH meter module is shown in Fig. 9 and Table 2 shows the voltage represented by the pH value. The values of voltage are ranging between 414.12 mV which equivalent to 0 ph value and -414.12 mV which equivalent to 14 pH value.

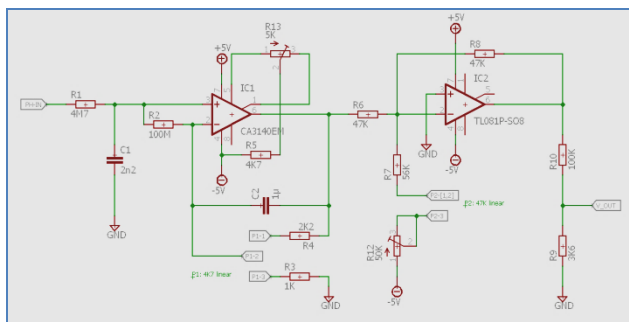

Fig. 9 Circuit diagram for pH meter module

Table 2: Voltage represents pH value

VOLTAGE (mV)	pH value	VOLTAGE (mV)	pH value
414.12	0.00	-414.12	14.00
354.96	1.00	-354.96	13.00
295.80	2.00	-295.80	12.00
236.64	3.00	-236.64	11.00
177.48	4.00	-177.48	10.00
118.32	5.00	-118.32	9.00
59.16	6.00	-59.16	8.00
0.00	7.00	0.00	7.00

### 3.2 Fish Feeder Concept

The fish feeder concept is designed with gravity concept where the fish feed will be spreading after the shutter is opened by timing control. The concept is shown in Fig. 10.

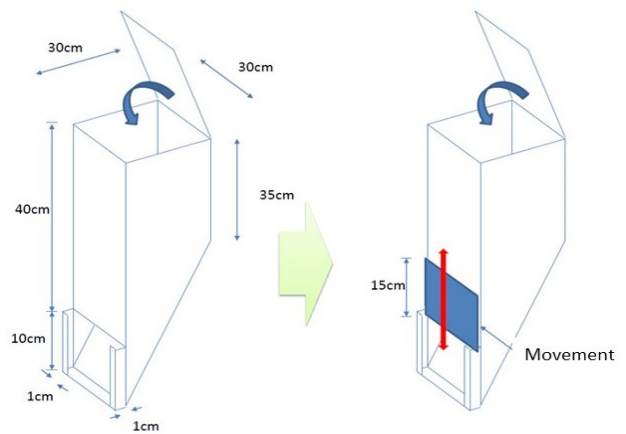

Fig. 10 Fish feeder concept

### 3.3 Water Filter Concept

The filtering process for this study is as shown in Fig. 11 which is applying the bell siphon concept. This process has three phases to make sure water will flow smoothly. The process flow is depicted in Fig. 12.



Fig. 11 Water filter using bell siphon concept.

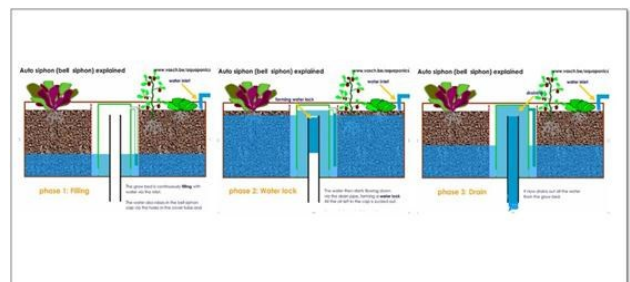

Fig. 12 Bell siphon concept [10]

### 3.4 Ultrasonic Sensor

In order to detect the distance of water level, the ultrasonic sensor is a suitable device to be used. It gives a ping signal to the distance and reflects back to receiver signal. In this process, we can use the signal to get any distance using the Arduino microcontroller. The concept of the ultrasonic sensor is shown in Fig. 13.

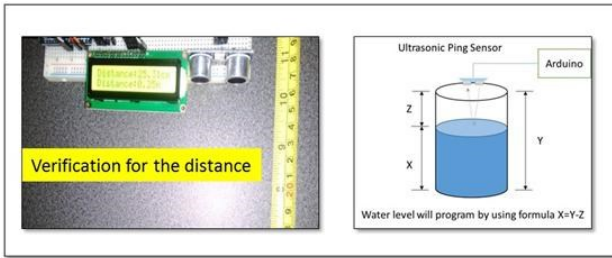

Fig. 13 The ultrasonic concept

### 3.5 Microcontroller Firmware

In this study, the Arduino IDE programming V1.6.6 is used to develop the program sequence or firmware of the microcontroller. Fig. 14 shows the flowchart of microcontroller (pH control and water level) and Fig. 15 is flowchart of microcontroller (Fish feeder and water pump).

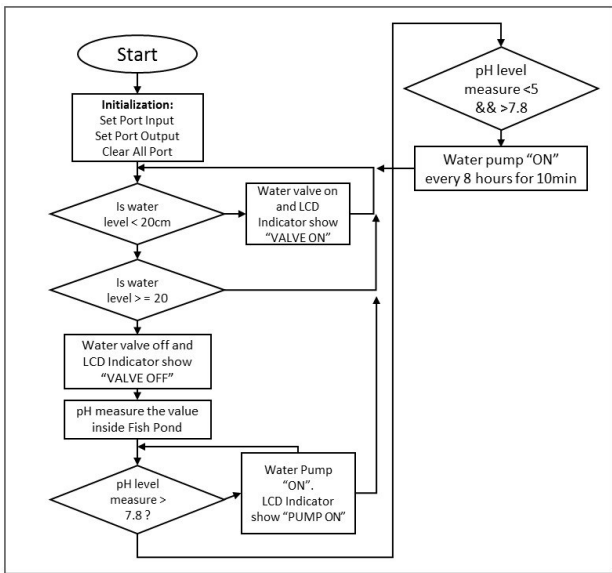

Fig. 14 Flowchart of the microcontroller coding (pH control and water level)

When the system in automatic mode, the sensor will detect the water level inside the water tank either high or low threshold level. If the volume inside tanker in lower level condition, the signal will be send to the input of microcontroller to “ON” the valve for the water source and the alarm will appear at LCD display “VALVE ON”. When the volume of water is high until the limit, water valve will be OFF condition and the LCD Display will display “VAVLE OFF”. The process is always continuous to meet the water level in good level.

The water from the pond will be pumped out by motor if the pH value is out of range (more 7.5pH) where the amount of ammonia is going to increase. The water will go through to the agriculture system connected by water piping. This process will remove the amount of ammonia or nitrate produced by fish manure and fish feed. The process will continuous by run until the pH value is in the range. If the pH value is always in the range, the water pump would be able to operate for every 8 hours to give water to plants for growing system.

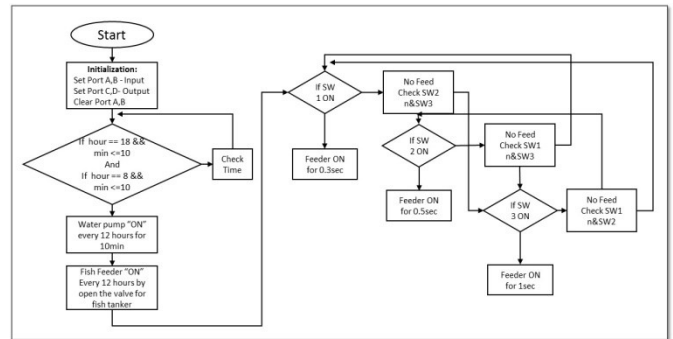

Fig. 15 Flowchart of the microcontroller coding (Fish feeder and water pump)

The process of the flowchart in Fig. 15 shows the scheduling for water pump and fish feeder operations. The water pump will operate every 12 hours to supply water from fish pond to plants for 10 minutes. The fish feeder will be operated by different selection switches represented with SW1, SW2 and SW3. Every single switch has their own programming for the timing open of shutter feeder depending on the size of fish. The operation of fish feeder also will be operated in twice per day scheduling by the microcontroller.

## 4. Results and Analysis

This section will explain the overall of outcomes for this study. A few measurements and results will be discussed in this section. It will also describe the whole operations of the system.

### 4.1 Conceptual Operation of the System

Two microcontrollers have been used inside of the control panel; Arduino MEGA and Arduino NANO. Both of the controllers has different task needed to the process. Fig. 16 shows the controller of the system.

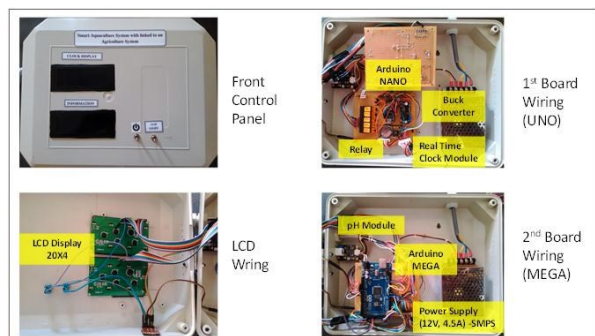

Fig. 16: Microcontrollers for the system

The Arduino MEGA is the main among the others controller used for this project. The pH value, water temperature, ultrasonic is the input for this microcontroller. For the output, there are the water pump, a solenoid valve (water source) and LCD display which are selected. The LCD displays the data information such as pH value, water temperature, a distance of water level, the operation of the water pump and water valve. The Arduino NANO functional to ensure the fish feeder power supply and water pump operates by time schedule and it is connected with RTC (Real Time Clock).

The overall of this project can be described in Fig. 17. The main parts or components used for this system are controller (Control Panel), pH Electrode, ultrasonic sensor, water valve, motor pump, two water tank, growing plant as a filter and fish feeder.

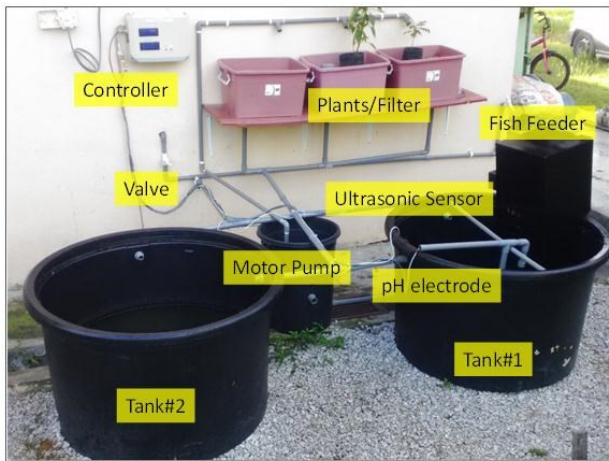

Fig. 17 Overall setup of the system

### 4.2 Water Pump Operation

If the pH value detected by pH electrode more than 7.5, the water pump will automatically ON. During this process, the analogue voltage value sensed by pH electrode and the information sent to the Arduino analogue input. And at the same time, the output will give the signal to relay in order to give power supply to the water pump. The LCD will also display the indication "PUMP ON" as shown in Figure 18. The water pump will pump the water go through by the piping and transfer to the plantation. This process will filter out the water by using the bell siphon. During this stage, the ammonia will be filtered out by the plantation.

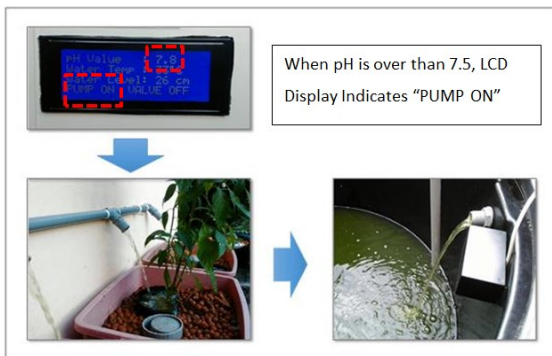

Fig. 18 The operation of water pump when pH is over than 7.5

### 4.3 Water Filtration

The operation of the system is to make sure the ammonia level is not over the limit or target inside the water tanker, which represented by pH value. If the pH value exceeds the target, the water pump will be ON and filter the water by a plant using the bell siphon concept.

Fig. 19 shows the result after and before filtering process. The result for pH value is good to compare with the previous value.



Fig. 19 Result before and after filtering process

### 4.4 Water Level Operation

Water level operation is one of the important parts of this study in order to become smart aquaculture system. It is to ensure the level of water not in lower or high condition. But in this study, the system decided only to detect the lower condition of the water level. For the higher level, the over flow concept is applied where the higher limit of water level is already fixed.

In this project, the ultrasonic sensor is applied to detect the water level inside the water tank, as shown in Fig. 20. We can know how distance or high of water inside the tanker. If the water level is too low as a limit, the LCD display will show "VAVLE ON". It is mean that water valve on and ready to supply the water inside the tanker.



Fig. 20 The ultrasonic sensor used in this study

### 4.5 Fish Feeder Operation

To complete the system, the implementation of the auto fish feeder is also important. In this study, the fish feeder system linked with clock setting by the control panel. The fish feeder system can set the timing of fish feed and the amount of grams needed by fish.

For this study, time clock was setting for 08:00 or 18:00 to supply fish feed inside water tank, and the amount in gram unit was setting by a toggle switch. SW1 represents 75 grams, SW2 represents 180 grams and SW3 represents 400 grams of fish feed. The selection of switch depends on the size of fish. Fig. 21 shows the fish feeder operation set by the clock.



Fig. 21 Fish Feeder operation set by time

#### 4.5.1 Result of fish feed by mass (gram) vs. time (sec)

The fish feeder system was verified for the mass of fish feed and timing for the shutter door open by a servo motor. The data for an average of 5 sample test for every 0.1 sec interval has been collected. The result is tabulated in Table 3, which is sample test for mass taken by time.

Table 3 Sample test for mass fish feed taken by time

Time (sec)	Test#1 (gram)	Test#2 (gram)	Test#3 (gram)	Test#4 (gram)	Test#5 (gram)	Average (gram)
0.1	0	0	0	0	0	0
0.2	20	30	25	30	25	26
0.3	80	70	75	85	80	78
0.4	135	135	130	150	130	136
0.5	180	185	200	190	195	190
0.6	235	225	225	230	230	229
0.7	330	325	335	320	330	328
0.8	415	400	405	410	410	408
0.9	460	475	475	470	465	469
1.0	525	525	520	525	525	524

From the Table 3, it can be transformed into the graph as shown in Fig. 22. From the graph, we can see it is an almost linear graph and we can conclude that the increase of time can effect to the increment of mass of fish feed. From the graph it can also represented by the linear equation,

$$m = 622.5t - 98.55 \tag{1}$$

where  $m$  is mass of the fish feed and  $t$  is time in second. Therefore, from the linear equation we can set the time of shutter open based on the amount of gram as per needed. From this study, the amount in gram for fish feed is summarized in Table 4.

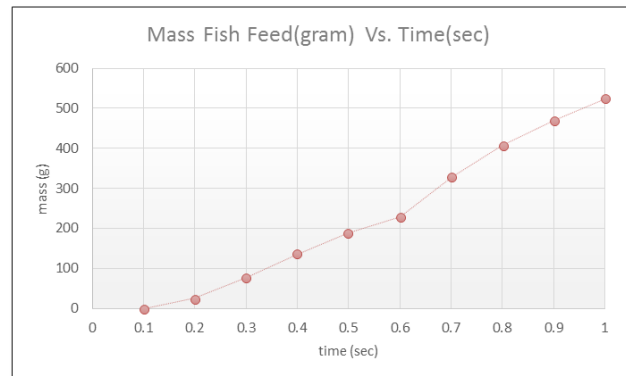

Fig. 22 Graph of fish feed mass (g) vs. time (sec)

Table 4 Selection fish feed time by the age of fish

Switch	Duration	Mass (gram)	Time setting
SW1	1 <sup>st</sup> month	75	0.3 sec
SW2	2 <sup>nd</sup> months	180	0.5 sec
SW3	3 <sup>rd</sup> months	400	0.8 sec

### 5. Conclusion And Suggestion For Future Advancement

The system developed in this study capable to monitor the pH value (which represents the amount of ammonia inside the fish pond tank). For other benefits, this system would able to increase the productivity of agriculture system by supplying ammonia waste from the aquaculture system. The process is operated in an automatic system. Other features are also included which are auto fish feeder system and the water level system. The auto fish feeder is functioning to give fish feed by timing with several setting time. It is operated by daily scheduling which has been set into microcontroller programming. The water level system, will detect the level of water in the tank to ensure the level is high enough. If the abnormal level happens inside of the water tank, water valve would able to be opened and water supplied into the tank.

There are several views need to be carried out for the future recommendation. During the study, it is found that the pH value drops below 6.0 which indicate acidity in the water. Hence, further analysis need to be done to know whether it is suitable for plant or not. If the acidity is good for plant, the current programming of the controller still can be used. Otherwise, the system needs to be updated with the additional command for water draining from the tank. Besides, the future system should be equipped with keypad or touch screen feature to ease the consumer for data editing or parameters setting. In addition, due to important of sensor accuracy, the auto calibration process is necessary to ensure the accuracy and efficiency of the system. In this decade, the smart

technology such as the internet and smart phone is the biggest application of the human life. Pertaining to this statement, the Internet of Things (IOT) will be implemented for this project connected to the Arduino. Every single movement can be monitored by using smart system monitoring (e.g SCADA System). Implementation of Bluetooth and Wi-Fi has their own disadvantages such as a low range for networking. The system will be connected to the internet via ethernet and can be monitored and accessed by the owner at any place, and the network coverage is over the range.

## Acknowledgement

The authors would like to acknowledge the UTM-GUP Grant from Universiti Teknologi Malaysia (UTM) and Malaysian Government with vote number Q.J130000.2523.11H49 for supporting this work.

## References

- [1] Shultz, K.A. and Cole, W.M. (1997). Development of an aquaponic system for system for the intensive production of Ti-lapia and hidroponic vege. *Aquaponics Journal, Nelson and Pade Inc.*, Oct/Nov 1997, 12-13.
- [2] Rakocy, J.E., Masser, M.P. and Losordo, T.M. (2006). Recirculating Aquaculture Tank Production Systems : Aquaponics — Integrating Fish and Plant Culture. *Southern Regional Aquaculture Center (SRAC) Publications*, No. 454, 1-16.
- [3] Bhatnagar, A and Devi, P. (2013). Water quality guidelines for the management of pond fish culture. *International Journal of Environmental Sciences*, 3(6), 1980–2009.
- [4] Hargreaves, J.A. and Tucker, C.S. (2004). Managing Ammonia in Fish Ponds. *South. Reg. Aquac. Cent.*, no. 4603, pp. 1–7.
- [5] Rakocy, J. (2007). Ten Guidelines for Aquaponic Systems. *Aquaponics J.*, 3(46), 14–17.
- [6] Canadian Council of Ministers of the Environment (2010). Canadian Water Quality Guidelines for the Protection of Aquatic Life: Ammonia,” *Canadian Environment Quality Guidelines*, p. 8.
- [7] Francis-floyd, R., Watson, C., Petty, D., and Pouder, D.B. (2012). Ammonia in Aquatic Systems. *Inst. Food Agric. Sci.*, vol. June, 1–4.
- [8] Sergeant, C. (2014). The Management of Ammonia Levels in an Aquaculture Environment. *Water/Wastewater*, 2–3.
- [9] Plan, S., Fox, B.K., Howerton, R. and Tamaru, C.S. (2010). Construction of Automatic Bell Siphons for Backyard Aquaponic Systems 1. *Biotechnology*, June 2010, 1-11.
- [10] Best bell siphon (auto siphon) ever explained. Retrieved from: <https://www.youtube.com/watch?v=gFokOynqOqQ>.