



Paramotor Trike Design and Analysis

Aravind Selvam¹, Zamri Omar^{1*}

¹Faculty of Mechanical and Manufacturing Engineering,
Universiti Tun Hussein Onn Malaysia, 86400 Parit Raja, Batu Pahat, Johor, MALAYSIA

*Corresponding Author

DOI: <https://doi.org/10.30880/paat.2023.03.01.001>

Received 20 February 2023; Accepted 9 June 2023; Available online 31 July 2023

Abstract: A paramotor trike refers to an ultralight aircraft that is attached to a paraglider. A trike with a rear-mounted engine provides thrust force, enabling the vehicle to take off. The main objective of this study is to develop the modelling simulation of a two-seater paramotor trike and analyze the stresses acting on the frame structure of the paramotor trike through static and drop test simulations. In this study, the paramotor trike conceptual design is developed using SolidWorks. The safety factor for the static test and drop test is satisfactory based on the deformation, strain, and stress results. Moreover, the paramotor trike that was developed achieved its lightweight goal of 99 kg with an ergonomic design and has a maximum takeoff weight of 246 kg.

Keywords: Ultralight aircraft, analysis, frame structure, conceptual design, safety factor

1. Introduction

The powered paragliding (PPG), or commonly referred to as paramotoring, is a type of recreational air sport. According to Feletti and Goin [1], as paramotoring gains popularity, there are unavoidably more incidents and injuries linked to it. As a result, safety-related parts of paramotor trike design should be enhanced in terms of the mechanical strength of the structure. In addition, the weight of the current paramotor trikes could be improved. Studies on the design of the paramotor trikes should be conducted in order to ensure the trike is able to withstand actual operational forces. The use of SolidWorks CAD software has enabled the production of highly accurate drawings and prepared the design for the trike capability tests in actual environments, allowing a good visualization of its features. The objectives of the research are to design a two-seat tandem paramotor trike, analyze the stresses acting on the chassis structure of the paramotor trike, and consider an ergonomic and light weight paramotor trike design.

2. Methodology

In this study, the process of the design phase starts with deciding the requirements that have to fulfil the objectives of the study. In order to evaluate the requirements for the new paramotor trike design, it is first necessary to identify the existing problems with the design of the paramotor trike. Then, conceptual design sketches should be generated that depict the advantages and disadvantages of each design idea. The idea selection process comprises evaluating concepts that best satisfy the demands of the client as well as other factors. It also requires evaluating and contrasting the advantages and disadvantages of the concepts.

Following that, concept evaluation is carried out based on the weighting rating method. A decision matrix called the weighted rating matrix provides a rating system to evaluate alternative designs. The ranking system, which indicates the evaluation of the criteria functionalities in each of the designs, implies the scoring system. As a preliminary finding, the two-seater paramotor trike will be drawn based on the suggested combinations in this section. To further understand the design process, the initial sketches made prior to brainstorming and the morphological analysis are also exhibited, as shown in Fig. 1(a). There are a total of 3 sketches to aid with the morphological method and 3 combination sketches to

*Corresponding author: zamri@uthm.edu.my

illustrate the potential product solutions.

The conceptual design of the paramotor trike should be developed into a computer-aided-design (CAD) model once the concept has been refined and finalized, as shown in Fig. 1(b). Thus, the frame structure of the CAD model could be analyzed. The mechanical strengths of the main frame structure of the paramotor trike design will be analysed by static analysis and drop test analysis using a simulation tool. For this study, Solidworks is used as the design and analysis software. Furthermore, the SolidWorks simulation feature will be used to verify the vehicle's functionality under real-world circumstances and demonstrate its feasibility. The initial step begins with the creation of the full-scaled 3D geometry. The factor of safety (FOS) of the paramotor trike design will be ascertained by the static and drop test analyses. If the intended FOS was not achieved by the design, modifications should be made by refining the model to obtain the desired FOS. This procedure will continue until the desired result is obtained.

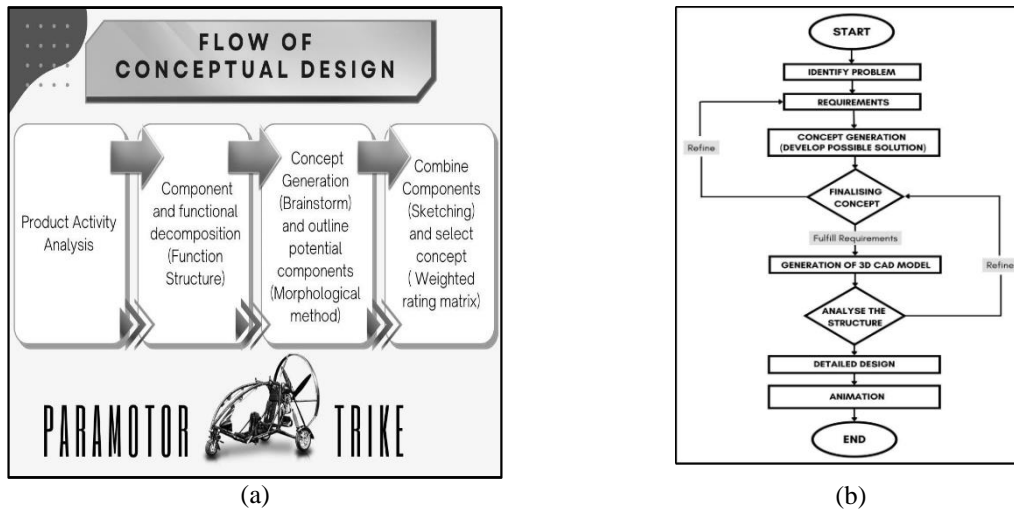

Fig. 1 - (a) Flow of conceptual design; (b) methodology flow chart

3. Conceptual Design and Analysis

The design requirements of the paramotor trike design should be the features that consumers of paramotor trikes appreciate the most. For a tandem two-seater paramotor trike, it should integrate with the following features: such as lightweight, portable, low operating cost, high mechanical strength, low maintenance cost, considerable fuel consumption, attractive design, efficient engine, and good quality, as shown in Fig. 2. Some features and significant standards were identified throughout the benchmarking process as having room for improvement.

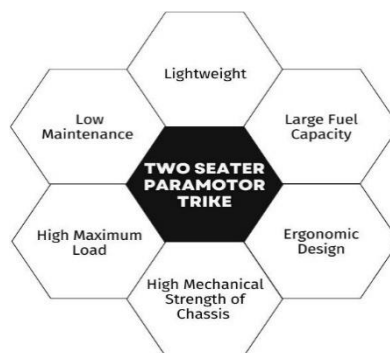
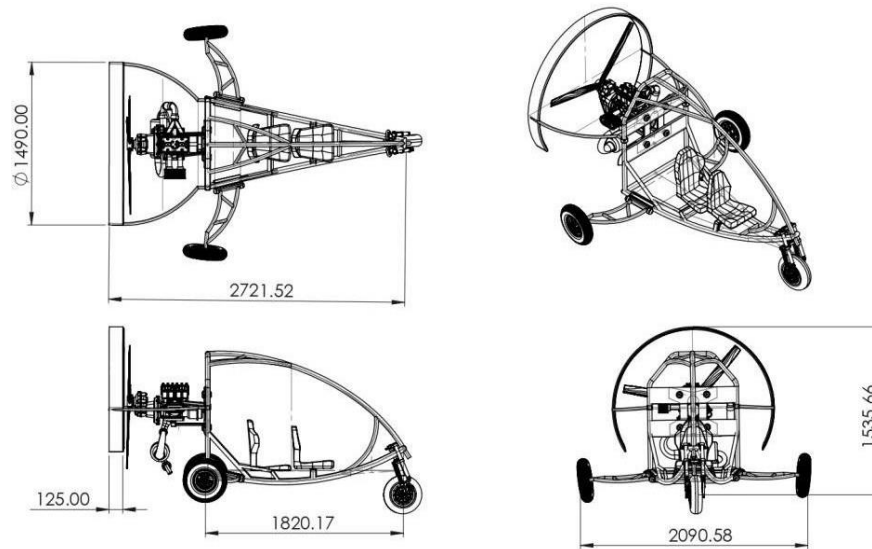

Fig. 2 - Concept generation of two seater paramotor trike

It is important to note that some paramotor trike designs do not have sufficient ergonomic features; for example, the seats lack back support. The engine used as a propulsion system for paramotor trikes varies, generally ranging from 200 cc to 500 cc. The Rotax 582 engine is one of the most common engine choices for tandem trikes. Normally, a 3-blade propeller is matched with the selected engine. The paramotor trike's serviceability and maintenance costs can be reduced by lowering the number of components. Moreover, the conceptual design of the paramotor trike should have two numbers of seats in a tandem seat type with a Rotax 582 engine. The paramotor trike design should be suitable for two people weighing 100 kg and also have a payload of 2 kg. Table 1 shows the specifications of the proposed tandem trike.

Table 1 - Design requirement

Design Requirements	
Requirement	Specifications
Number of seats	2
Seat Type	Tandem
Passenger and pilot weight	100kg per person
Engine	64 HP (Rotax 582)
Payload	2 kg

**Fig. 3 - Overall dimensions of the trike design**

The 3D conceptual designs are developed in accordance with the methodology principles. All dimension modifications are based on several selected trike reference designs. The SolidWorks weldments are used to create the 3D model, which is then translated into STEP files and imported into the simulation software for improved meshing. The final design is created based on the trike reference dimension, as shown in Fig. 3, which depicts the final design in front, side, and isometric views, as well as its overall dimensions.

3.1 Analysis

There are two types of analysis that are conducted in SolidWorks: the static test and the drop test.

3.1.1 Static Test

In order to do the static analysis, a SolidWorks static study must be generated. Then, the static properties must be defined. The material for the solid, the shell, or the beam must be selected. After that, each body, shell, and component is supported by its own constraints or by contact conditions and connectors connecting it to other elements or the ground. After determining the fixed support, external loads must be added to the model. After meshing, the static study is then ready to run. However, the system automatically meshes it prior to operation. The process of analysis and simulation is shown in Fig. 4.

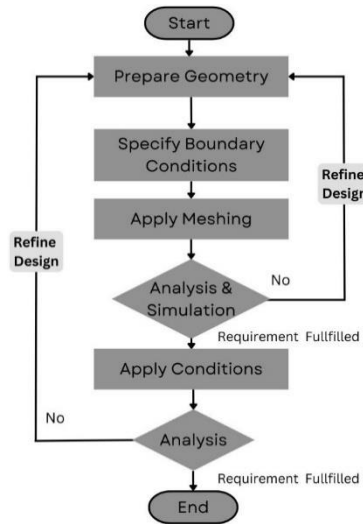

Fig. 4 - The process of analysis and simulation

3.1.2 Drop Test

The drop test analysis is to represent the hard landing situation that is commonly happened in the early stages of the paramotor training. In Solidwork simulation environment, the trike model is dropped from a set height onto a specific surface with a specific drop velocity. As part of a product quality management, it is frequently undertaken to ensure the product's safety and durability. SolidWorks simulation that simulates dropping a model to the ground with a set of parameters in order to determine the model deformation, displacement, stress, and strain. The selected material must initially be applied to the component. Then, the drop test setup should determine all drop test settings. The define/edit tab will then display all drop test options. The height from which the camera is lowered refers to the drop height or the velocity with which the camera reaches the ground based on the fall parameters of velocity at impact.

3.2 Materials Selection

For choosing the material, yield stress, density, and the affordability of the material in the market should be considered. In this study, aluminium is selected for the body frame of a structure since it must be both strong and lightweight. Aluminum has a balanced density and yield strength, making it ideal for a lightweight tandem paramotor trike. Due to its availability with 24 kg/mm² yield strength, aluminium 6061-T6 is selected as one of the lightest materials for the proposed tandem trike. The aluminium 6061-T6 properties are given in Table 2. It shows the material characteristics of 6061-T6 aluminium [3], which has high-to-moderate strength, exceptional corrosion resistance, outstanding machinability, and great weldability. Additionally, aluminium 6061-T6's corrosion resistance makes it an appropriate material for air and hydraulic pipe and tube [4]. Therefore, 6061 aluminium offers more strength compared to other alloys for applications requiring a material with the characteristics of being both strong and lightweight.

Table 2 - The material properties of Aluminium 6061-T6

Model type:	Linear Elastic Isotropic
Yield strength:	2.75 x 10 ⁸ N/m ²
Tensile strength:	3.1 x 10 ⁸ N/m ²
Elastic modulus:	6.9 x 10 ¹⁰ N/m ²
Poisson's ratio:	0.33
Mass density:	2,700 kg/m ³
Shear modulus:	2.6 x 10 ¹⁰ N/m ²

4. Structural Load Test

The trike structure must be designed to have sufficient strength in all operational conditions. The fundamental requirement is to ensure that the trike is strong enough to carry loads such as the pilot, passengers, fuel, and the trike itself. These loads are referred to as static loads. Beginners frequently experience a difficult landing during operations because the flare is insufficient, almost causing the trike to fall to the ground. Normally, this "drop" happens at a height between 3 and 5 feet above the ground. Therefore, the trike structure should have sufficient strength to overcome the load during a hard landing. The hard landing situation can be simulated with the following section.

4.1 Input Parameters

The load simulation requires input values for loading and drop test parameters, as shown in Table 3.

Table 3 - Loading values and simulation parameters

Type of load	Value
Passenger weight (2 persons)	200 kg
Payload (flying equipment)	2 kg
Engine weight (Rotax 582)	29.1 kg
Fuel weight	20 Litres (14.6 kg)
Drop height	1.5m
Drop velocity	Due to gravity

The trike model is prepared using SolidWorks weldments and later converted into STEP files, and exported to ANSYS software for simulation results [5]. The fixed geometry is between 2 vertexes and 3 faces of the solid body. Furthermore, the mass of the trike model is 102.256 kg. The loadings applied to the frame structure are highlighted in the documented SolidWorks file. Meanwhile, the volume is 0.0378725 m³ with a density of 2,700 kg/m³ and 1,002.1 N of weight. Then all loads are applied and meshed according to the requirements [6]. Table 4 shows the trike model parameters ready for simulation.

Table 4 - Meshing sizes, nodes, and elements

Type	Static load			Drop test		
	Size(mm)	Nodes	Elements	Size(mm)	Nodes	Elements
T1	10mm	479001	285890	30mm	40949	47309

4.2 Results and Discussion

Initially, a vertical force of 2125 N is applied to the beams of the trike frame. The 2125 N force is the sum of the weight of two persons, a payload, and gasoline. Meanwhile, the engine weight for the horizontal force is determined to be 285 N.

4.2.1 Results of Static Test

Fig. 5 depicts the static load simulation results in terms of strain, stress, displacement, and factor of safety. Based on the obtained results, the highest applied strain is 1.186 x 10⁻⁴ N/m² and the minimum applied strain is 1.978 x 10⁻¹⁰ N/m². The maximum strain is less than the yield strength of the frame structure; hence, the frame structure of the paramotor trike can resist the strain without deforming permanently. The maximum stress is 1.608 x 10⁷ N/m², and the minimum stress is 26.33 N/m². In addition, the yield strength of the frame structure is greater than the applied stress; therefore, the frame structure of the paramotor trike can resist the maximum stress without permanent deformation. In the static test, the vector distance between an initial model position and the final position is what is meant by this term. The maximum resultant displacement is 7.036x10⁻² mm and the minimum is 1.000 x10⁻³⁰ mm. As depicted in Fig. 5(d), the maximum and minimum factors of safety for the trike are 17 and 3, respectively. This is far above the common factor of safety for a typical flying vehicle, and therefore the paramotor trike model is very strong and safe.

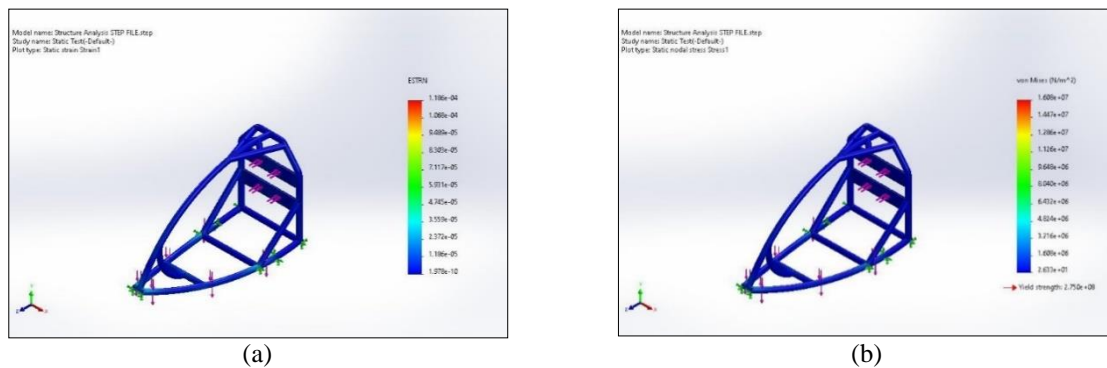

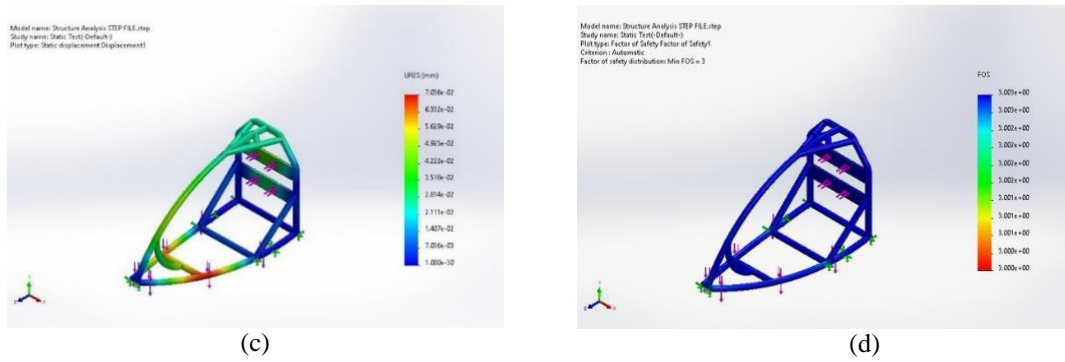

Fig. 5 - Static load simulations results (a) strain; (b) stress; (c) displacement; (d) factor of safety

4.2.2 Results of Drop Test

Results for the drop test are shown in Fig. 6. The maximum stress is $1.725 \times 10^8 \text{ N/m}^2$ and the minimum stress is $2.495 \times 10^5 \text{ N/m}^2$. In addition, the yield strength of the frame structure is greater than the stress impact during the drop test; therefore, the frame structure of the paramotor trike can resist the maximum stress without deforming permanently.

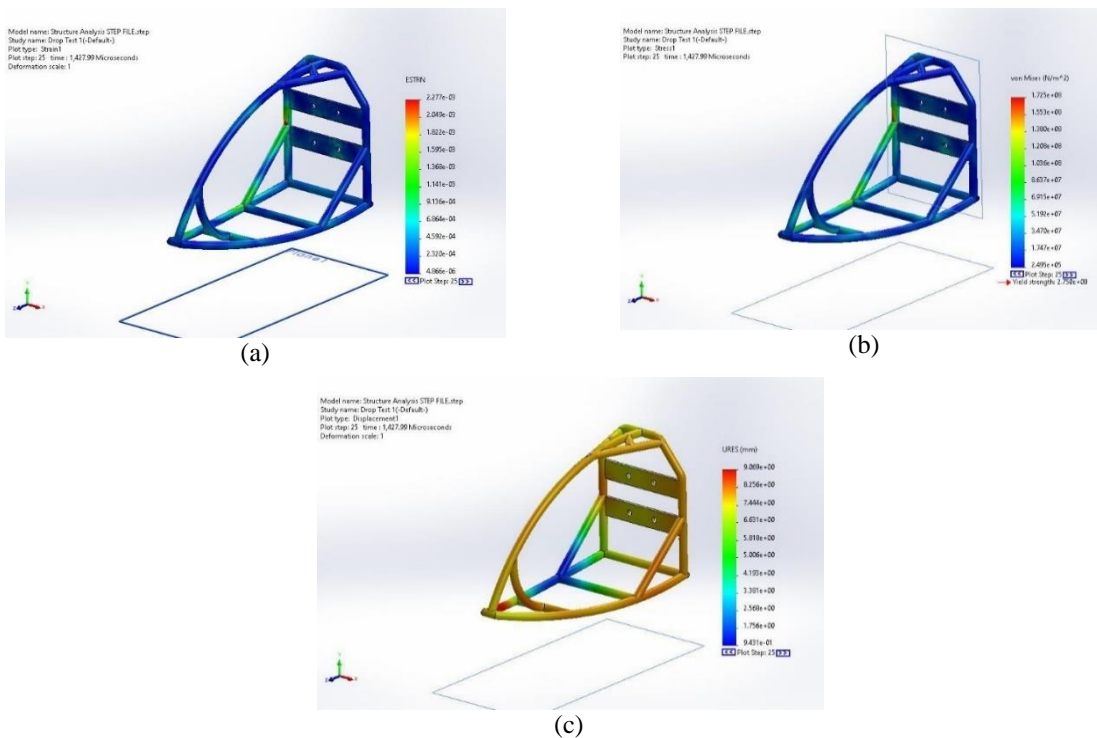

Fig. 6 - Drop test simulations results (a) strain; (b) stress; (c) displacement; (d) factor of safety

Based on the contour map in Fig. 6, the highest resultant displacement is 9.0609 mm and the minimum displacement is 0.9431 mm. The frame structure contour map is predominantly yellow in colour. The greatest strain obtained based on the results is 2.277×10^{-3} and the minimum strain is 4.866×10^{-6} . The maximum strain determined by the drop test is less than the yield strength of the frame structure; hence, the frame structure of the paramotor trike can resist the strain without permanent deformation.

4.2.3 Factor of Safety for Drop Test

The factor of safety for the drop test can be calculated as:

$$FOS = \frac{\text{Yield Strength}}{\text{Maximum Stress}} = \frac{2.75 \times 10^8}{1.725 \times 10^8} = 1.5$$

The yield strength is the stress that begins the material's deformation. Consequently, the minimum factor of safety according to the drop test is 1.5. This factor of safety is still within the safe operational limit but is the minimum allowable

in a typical flying vehicle. Table 5 summarizes the simulation results for both static and drop tests. The maximum safety factor recorded for the paramotor trike frame is 17, while the lowest safety factor for the model is 1.5. Even when loaded with engine, passengers, fuel, and flying equipment, the paramotor trike structure is safe.

Table 5 - Results of static test and drop test

Static Load Test				Drop Test			
Maximum displacement (mm)	Maximum Strain (mm/mm)	Maximum Stress (N/m ²)	FOS (minimum)	Maximum displacement (mm)	Maximum Strain (mm/mm)	Maximum Stress (N/m ²)	FOS (minimum)
7.036×10^{-2}	1.186×10^{-4}	1.608×10^7		9.069	2.227×10^{-3}	1.725×10^8	
Minimum Resultant displacement (mm)	Minimum Strain (mm/mm)	Minimum Stress (N/m ²)	3.0	Minimum Resultant displacement (mm)	Minimum Strain (mm/mm)	Minimum Stress (N/m ²)	1.5
1.000×10^{-30}	1.978×10^{-10}	26.33		0.9431	4.866×10^{-6}	2.495×10^5	

Based on the results of the drop test, the minimum safety factor is 1.5. We can therefore conclude that the frame structure has a high level of strength. The static test and drop test demonstrate the loads and their effect on the trike's structural design. The static test applies a vertical force of 2,125 N and a weight force of 285 N. In the meantime, the drop test simulates the structure drop test at 9.81 m/s. The design has been successfully assessed after the meshing settings have been optimized. From the results, we can conclude that the conceptual design of the paramotor trike incorporates materials with excellent mechanical strength.

4.3 Ergonomic and Lightweight Aspects of The Design

As demonstrated in the Fig.s above, the ergonomic design has been realized in terms of the seated posture [7]. The model has been constructed with adequate hand and body clearances at the proper work heights and equipment reach distances. Therefore, the design of the paramotor trike is safe, pleasant, effective, and functional [8]. The purpose of the research is to develop a lightweight paramotor trike. The hypothetical design has a mass of 98.889 kg based on the reference trike design. Consequently, the conceptual design of the two-seater paramotor trike has achieved the research objective by being the lightest paramotor trike compared to commercially available paramotor trikes. Besides, the fuel tank size of 60 litres is the largest among commercial paramotor trikes. In addition, according to the studies, the paramotor trike can handle a maximum weight of 246 kg. Therefore, the maximum weight is considerably better than most trikes reported in [9]. In addition, the design safety factor is 1.5, which is a safe situation. The greater the number of FOS, the more secure the product design or structural framework.

4.4 Conclusion

In conclusion, the objectives of the study were achieved. This research would not have been possible without the information gathered. One reference trike design is chosen to be the model that is suitable for load simulation. Based on the static test and drop test, the deformation, strain, stress, and FOS values of the design are satisfactory. In short, the maximum load of 246 kg is the result of the stress acting on the paramotor trike frame and the load capacity of the structure. In addition, the safety aspect of the conceptual design is secure with a lightweight trike structure of 99 kg.

Acknowledgement

My deepest gratitude goes to my supervisor, Associate Professor Dr. Zamri Bin Omar, for providing the Author with all direction, encouragement, patience, and his knowledge for the research. In reality, my supervisor enthusiasm for paramotor trikes has provided me with an abundance of inspiration to explore this topic. Furthermore, I would like to thank my parents for giving me moral support and motivation. My sincere thanks to all lecturers in UTHM who have taught me, without their advice and guidance, my learning experience would have been extremely challenging.

References

- [1] Feletti, F., & Goin, J. (2014). Accidents and injuries related to powered paragliding: A cross-sectional study. *BMJ Open*, 4(8). doi:10.1136/bmjopen-2014-005508
- [2] Fly products. (n.d.). Retrieved May 29, 2022, from <http://www.flyproducts.com/eng/>
- [3] Jawalkar, C. S., & Kant, S. (2015). A review on use of aluminium alloys in aircraft components. *i-Manager's Journal on Material Science*, 3(3), 33–38. <https://doi.org/10.26634/jms.3.3.3673>
- [4] Seli, H., Awang, M., Ismail, A. I., Rachman, E., & Ahmad, Z. A. (2012). Evaluation of properties and FEM model of the friction welded mild steel-AL6061-alumina. *Materials Research*, 16(2), 453–467. <https://doi.org/10.1590/s1516-14392012005000178>
- [5] Kurowski, P. M. (2016). *Engineering analysis with Solidworks simulation 2016*. SDC Publications.
- [6] Mustapha, K. B. (2022). *Practical finite element simulations with Solidworks 2022: An Illustrated Guide to performing static analysis with Solidworks simulation*. Packt Publishing.
- [7] Haslegrave, C. M., & Holmes, K. (1994). Integrating ergonomics and engineering in the technical design process. *Applied Ergonomics*, 25(4), 211–220. doi:10.1016/0003-6870(94)90002-7
- [8] Sagot, J.-C., Gouin, V., & Gomes, S. (2003). Ergonomics in product design: Safety factor. *Safety Science*, 41(2-3), 137–154. [https://doi.org/10.1016/s0925-7535\(02\)00038-3](https://doi.org/10.1016/s0925-7535(02)00038-3)
- [9] Global paramotors market: 2022-2027: Expected to reach USD 23 million and growing at CAGR of 4.1%. *rfdtv.com*. (2022, June 13). Retrieved June 15, 2022, from <https://www.rfdtv.com/story/46674919/global-paramotors-market-2022-2027-expected-to-re> Sokolava, K. (2021, December 8)