

AL-WEFAQ Car Rental Reservation System

Ahmed Mukhtar Sheikh Ahmed¹, Mohd Amin Mohd Yunus^{1*}

Fakulti Sains Komputer dan Teknologi Maklumat,
Universiti Tun Hussein Onn Malaysia, Parit Raja, Batu Pahat, 86400, MALAYSIA

DOI: <https://doi.org/10.30880/aitcs.2023.04.02.040>

Received 24 June 2023; Accepted 25 October 2023; Available online 30 November 2023

Abstract: The advancement of technology has had a significant impact on the development of various industries. However traditional car rental businesses often do not advertise their vehicles online, making it difficult for customers to locate and reserve vehicles. This creates a need for a comprehensive platform that can facilitate the car rental process for both businesses and customers. Such a platform would enable car rental businesses to promote their vehicles and increase their visibility to potential customers. Additionally, customers would have access to a wide range of vehicles available for rent, without the need to waste time searching for a suitable car. The goal of this project is to enhance the efficiency and ease of the car rental system by providing an intuitive, user-friendly platform for both admin and customers. This project is a website for a car rental company that allows customers to view available cars, register, see their profiles, and book cars online. In order to book a car, the user must first log in to the system. From there, they can easily search for and reserve cars by providing information such as booking dates and messages. The website displays all relevant car information, including features and an overview, and allows users to write testimonials and modify their profiles and passwords at any time. Admins can add and manage car brands, cars, bookings, testimonials, and pages, among other things. The website is designed to be user-friendly, with a simple layout that is easy to understand, use, and navigate. Overall, it aims to make the process of car rental convenient and straightforward for its users.

Keywords: Rental, Reservation, System, Car

1. Introduction

Car rental System refers to the process of overseeing the operation of a car rental business. This includes tasks such as managing the fleet of vehicles, setting rental rates, handling customer reservations and inquiries [1]. Effective car rental can help to ensure the success and profitability of a car rental business. It involves keeping track of the financial performance of the business and adjusting pricing and operational strategies as needed. It also involves maintaining strong relationships with customers to encourage repeat business and positive word-of-mouth advertising [2].

However, the use of information technology and the internet has greatly improved various business processes and communication within the car rental industry. AL-WEFAQ is a rental car company that specializes in providing vehicles to customers. The Al-Wefaq Company currently utilizes a manual system for the recording and management of rental activities. However, this approach has several limitations and disadvantages for both the company and its customers. This method may also limit the scalability and efficiency of the company's rental operations, negatively impacting the company's ability to meet customer demand and grow the business [3].

The purpose of this project is to develop a web-based system for the AL-WEFAQ car rental company, which will enable customers to browse and book available vehicles, register for an account, and utilize an online vehicle reservation tool. The system offers a range of services, including an online vehicle reservation tool that allows customers to reserve cars in advance of their pick-up date and time. It also includes a customer registration system to store and track customer information and transactions, and to improve services for customers.

To summarize the several issues that AL-WEFAQ facing are, the utilization of a manual system for the recording of rental activities within a car rental company is lacking in its effectiveness as a means of facilitating business. This is due to the laborious and time-consuming nature of manually documenting each individual transaction. The manual system causes a delay in the process and increases the chances of mistakes, which can lead to inefficiency in helping the owner to manage the business effectively [4]. As well as Challenges for customers in finding an AL-WEFAQ shop, to reserve a car.

Implementing a web-based system for the recording of rental activities has the potential to greatly enhance the efficiency and accuracy of these processes, a web-based system can provide a more streamlined and user-friendly interface for customers, allowing them to easily access information and make reservations from any location this would improve customer satisfaction and make it easier [5].

2. Related Work

Three similar systems have been studied and compared with the proposed system. The first system is Jbcarrentalservices. The user can access two modules with the password and username: the searching module and booking module. In the searching module, the user needs to state the type of rental, location where to pick up and pick-up date and drop date and click "SEARCH» button to choose the type of car and the best prices. Meanwhile, in the booking module, users need to reserve the date and type of car they have been chosen before.

The second system is Rentalcars.com, the system categorizes drivers by their age. Customers could also look up details on their reservations. The user must input the email address and reservation information to return the booking. The two modules that make up Rentalcars.com are the searching and booking modules. The user must first input the nation, city, and location in the search function. They must then select a pick-up and drop-off date and specify the driver's age. After the user has completed every one of the fields, they must click "SEARCH." Furthermore, in the booking module, the system would show the types of vehicles and their prices once a user clicks the "SEARCH" button. To reserve a car, the user must select a vehicle and click the "BOOK NOW" button.

The third system is Orbitz, Customers can view details about their reservations by entering their email and reservation information. The website has a search function where the user enters their location, pick-up and drop-off dates. The booking module shows the types of vehicles and their prices when the user searches. To reserve a car, the user selects a vehicle and clicks the reserve button. The proposed system is called car rental system for AL-WEFAQ, it's replaced the manual method that is used until now. Furthermore, customers can register, login, and book.

Table 1 shows the results of studies of existing systems and comparisons have been made against some important features found in the system.

Table 1: Comparison between existing systems and proposed system

Features/System	Jbcarrentalservices.com	Rentalcars.com	Orbitz.com	Proposed System
Registration	X	X	√	√
Log in	X	X	√	√
Manage Information	√	X	X	√
Search	√	√	√	√
Booking	√	√	√	√
Generate Report	X	X	√	√
Platform	Multiple	Multiple	Multiple	Multiple

3. Methodology

Software development involves a series of steps leading up to implementation, and a standard set of steps, known as the software development life cycle (SDLC), is typically followed. There are various types of SDLC models, and the one that will be used for this project is the Prototyping model. This model involves creating a prototype, or a preliminary version of the software, and using it to gather feedback and make improvements. This approach allows for flexibility and the ability to make changes as needed during the development process [6] – [8].

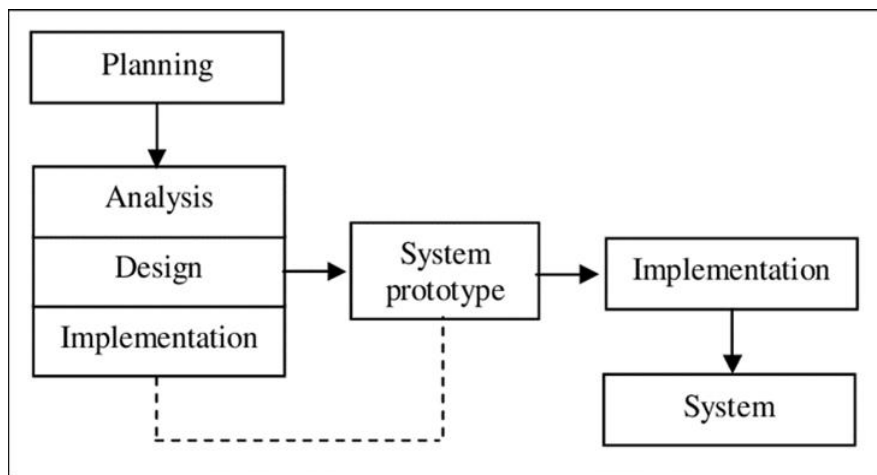

Figure 1: Prototype Methodology

There are total of nine phases from the prototype model. As shown in **Table 2**, each phase has its own assignment and output that is needed to produce during the entire project development. Besides that, the output was completed within the specific days that have been given.

Table 2: Software development activities and their task

Phase	Task	Output
Planning	identifying the problem, scope, and objectives. The next step is to determine how to construct the web-based system and its features using the collected data	project Proposal Background Problem Statement Objective Scope Methodology Significant, Expected result
Analysis	Identify system requirement. Comparison of existing system	Data Flow Diagram (DFD) Entity Relationship Diagram (ERD) System Comparison.
Design	5 main processes in data flow diagram that consists of manage profile, manage car, book, rating, and generate report. Data model is created	Major modules have been describing in this phase.
Implementation	Build and implement the interface, coding language, and connect the database.	The system has been developed.
Testing	Improvements will be implemented based on the requests of the consumers during this time. Multiple updates will be made until the system meets the user's requirements.	The system is being tested by the user.

Table 3 shows the functional requirements for the developed system.

Table 3: Functional requirements

No.	Modules	Description
1.	Registration Module	<ul style="list-style-type: none"> Customers are able to create an account on the system by providing a username and password.
2.	Login Module	<ul style="list-style-type: none"> Customers are allowed to login into the system using a registered username and password. The system should notify the Customer if any invalid input is detected. The system should navigate the Customer to the main page upon successful login
3.	View Menu	<ul style="list-style-type: none"> Customer should be able to view the various types of vehicles available.
4.	Booking Module	<ul style="list-style-type: none"> Customer should be able to book any type of the car. Customers should be able to check the booking availability.
5.	Facility Module	<ul style="list-style-type: none"> Admin should be able to insert new car. Admin should be able to delete bookings.
6.	Report Module	<ul style="list-style-type: none"> Admin should be able to generate a report of vehicles that have been booked on a specific date.

Table 4 shows the Non-functional requirements of developed system.

Table 4: Non-Functional requirements

Requirements	Description
Performance	<ul style="list-style-type: none"> The wait time between pages should not be more than 10 seconds.
Reliability	<ul style="list-style-type: none"> The system should be able to work in any browser.
Security	<ul style="list-style-type: none"> Users should only be able to access the system by providing their username and password.

4. System Analysis

Figure 2 illustrates the process of registering and accessing the system as an administrator or customer. Once registered, customers can manage their personal information, which is stored in the user data store. Administrators, on the other hand, can manage the details of their vehicles, which are stored in the car data store.

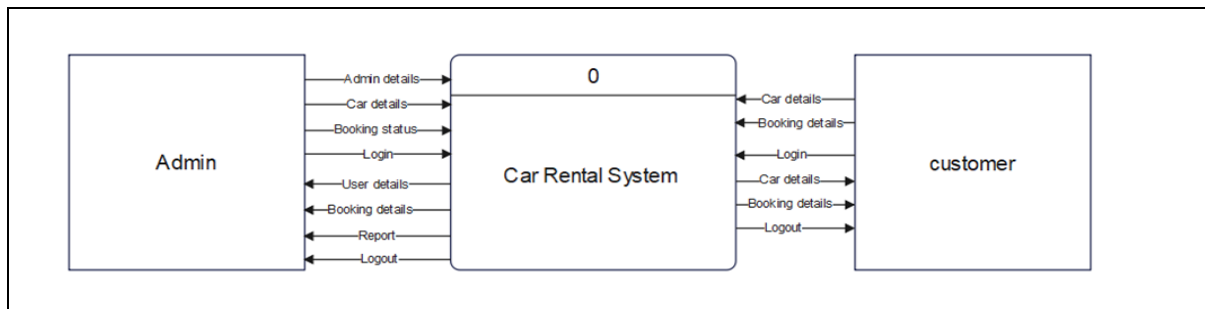

Figure 2: Data Flow Diagram Context Diagram (DFD CD)

Figure 3 shows that admin and customer must register to access the system. All the customers and admin can manage their details and all the information will be stored in user, as well as for admin the information will be stored in admin.

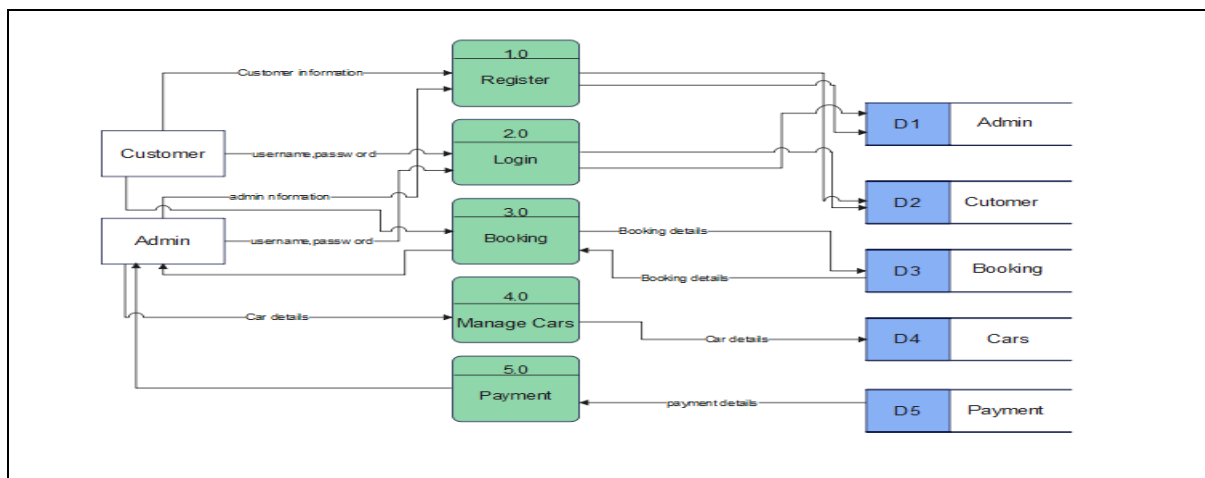

Figure 3: Data Flow Diagram Level 0 (DFD 0)

Figure 4. shows Entity Relationship Diagram (ERD) for proposed system.

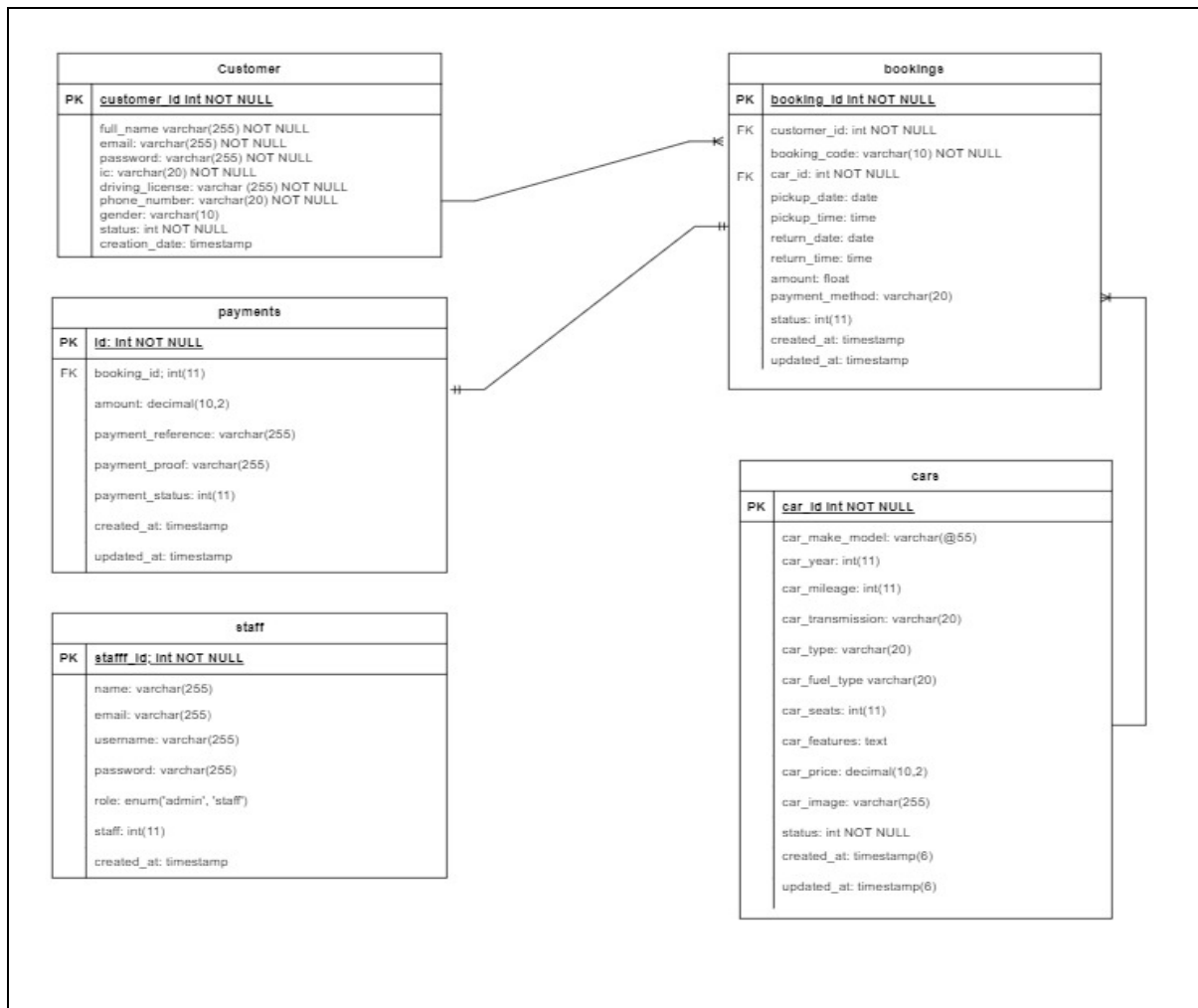

Figure 4: Entity Relationship Diagram (ERD)

5. Interface Design

In this process, Customer need to log into system by providing the correct username and password by using login interface as shown in **Figure 5**, In Registration page, Customer need to register into system by providing username, email, password as shown in **Figure 6**.

Figure 7 Show the home page for proposed system. The customer should be able to see the profile, booking, summary as well as log out from the system.



Figure 5: Login Interface Design



Figure 6: Registration Interface Design

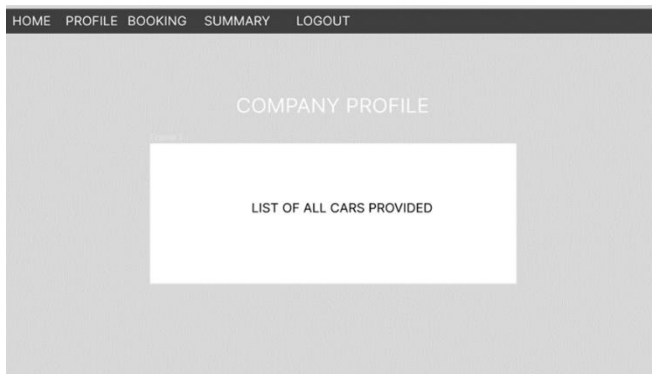

Figure 7: Home page Interface Design

6. Results and Discussion

This section describes the system implementation process and the system testing for the developed system. All planned processes and tasks for the development of the 'Al-Wefaq Car Rental Reservation System' project have been completed successfully.

6.1 Functional Module Development

This section describes the development of functional modules in a system. Program code is provided to aid clarification. **Figures 8** and **9** show the server-side coding and the user interface of the user login.

```

<!-- Login form -->
<form id="loginForm">
  <div class="form-group">
    <label for="loginEmail">Email address /label>
    <input type="email" class="form-control" name="email" id="loginEmail" placeholder="Enter email">
  </div>
  <div class="form-group">
    <label for="loginPassword">Password /label>
    <input type="password" class="form-control" name="password" id="loginPassword" placeholder="Enter password">
  </div>
  <button type="submit" onclick="loginUser(event)" class="btn btn-primary">Login /button>
</form>
<p class="text-center mt-3">Don't have an account? <a href="#" id="switchToRegister">Register /a</p>
</div>
<div id="registerContent" style="display: none;">
</div>
</div>

```

Figure 8: Account Login Code

Figure 9: Account Login Page

Figures 10 and **11** show the coding and the user interface of the account registration. Customers can enter information such as name, email address, phone number, gender, password, and uploading driving license in the interface's input fields. An error message will appear if the user submits the form without filling out all or some of the required fields, depending on the situation.

```

<!-- Register form -->
<form id="registerForm">
  <div class="form-group">
    <label for="registerName">Full Name /label>
    <input type="text" class="form-control" name="name" id="registerName" placeholder="Enter full name" required>
  </div>
  <div class="form-group">
    <label for="registerEmail">Email address /label>
    <input type="email" class="form-control" name="email" id="registerEmail" placeholder="Enter email" required>
  </div>
  <div class="form-group">
    <label for="registerIC">IC /label>
    <input type="text" class="form-control" name="ic" id="registerIC" placeholder="Enter IC number" required>
  </div>
  <div class="form-group">
    <label for="registerPhone">Phone Number /label>
    <input type="text" class="form-control" name="phone" id="registerPhone" placeholder="Enter phone number" required>
  </div>
  <div class="form-group">
    <label for="registerGender">Gender /label>
    <select class="form-control" name="gender" id="registerGender">
      <option value="male">Male /option>
      <option value="female">Female /option>
    </select>
  </div>
  <div class="form-group">
    <label for="registerDrivingLicense">Upload Driving License /label>
    <input type="button" value="Choose File" /> No file chosen
    Upload image (png or jpeg) or pdf only
  </div>
  <div class="form-group">
    <label for="registerPassword">Password /label>
    <input type="password" class="form-control" name="password" id="registerPassword" placeholder="Enter password" required>
  </div>
  <button type="submit" class="btn btn-primary">Register /button>
</form>
<p class="text-center mt-3">Already have an account? <a href="#" id="switchToLogin">Login /a</p>
</div>

```

Figure 10: Customer Registration Code

Figure 11: Customer Registration Page

Figure 12 and **Figure 13** show the coding and the interface of the list of all the bookings, important information to facilitate the processing of the booking. The information being displayed here are the booking ID, car model, pickup date, return date, payment method, total amount, booking status, and action options which include viewing more information related to that booking.

```

<table class="table table-bordered">
  <tr>
    <th>Booking ID</th>
    <td>{{ Booking_details.booking_code }}</td>
  </tr>
  <tr>
    <th>Customer Name</th>
    <td>{{ Booking_details.full_name }}</td>
  </tr>
  <tr>
    <th>Customer License</th>
    <td>{{ if (Booking_details.driving_license) != "" }}<a href="{{ WEBSITE_URL }}/assets/driving_license/">
  </tr>
  <tr>
    <th>Car Model</th>
    <td>{{ Booking_details.car_make_model }}</td>
  </tr>
  <tr>
    <th>Pickup Date</th>
    <td>{{ Booking_details.pickup_date }}</td>
  </tr>
  <tr>
    <th>Pickup Time</th>
    <td>{{ Booking_details.pickup_time }}</td>
  </tr>
  <tr>
    <th>Return Date</th>
    <td>{{ Booking_details.return_date }}</td>
  </tr>
  </table>
    
```

Figure 12: Booking Code

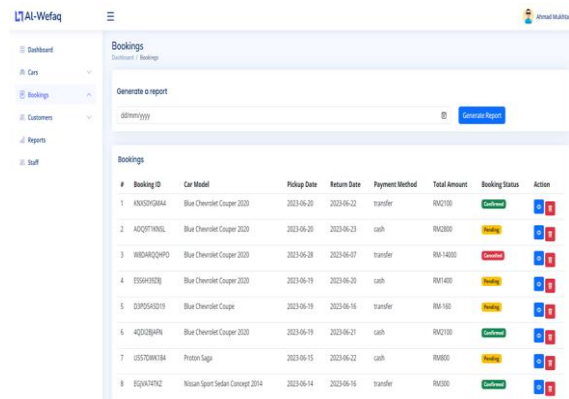

Figure 13: Booking Page

Figure 14 and **Figure 15** show the coding and interface, the admin can take action such as delete car or deactivated or add new car.

```

<div class="modal-title">Add New Car</div>
<button type="button" class="btn-close" data-bs-dismiss="modal" aria-label="Close"></button>
</div>
<div class="modal-body">
  <form id="addCarForm" class="needs-validation" novalidate enctype="multipart/form-data">
    <div id="carStatus" class="alert" style="display: none"></div>
    <div class="row mb-3">
      <div class="col-md-4">
        <label for="carMakeModel" class="form-label">Car Make and Model</label>
        <input type="text" name="carMakeModel" class="form-control" id="carMakeModel" required>
        <div class="invalid-feedback">Please enter the car make and model.</div>
      </div>
      <div class="col-md-4">
        <label for="carYear" class="form-label">Car Year</label>
        <input type="number" name="carYear" class="form-control" id="carYear" required>
        <div class="invalid-feedback">Please enter the car year.</div>
      </div>
      <div class="col-md-4">
        <label for="carMileage" class="form-label">Car Mileage</label>
        <input type="number" name="carMileage" class="form-control" id="carMileage" required>
        <div class="invalid-feedback">Please enter the car mileage.</div>
      </div>
    </div>
    <div class="row mb-3">
      <div class="col-md-4">
        <label for="transmission" class="form-label">Transmission</label>
        <input type="text" value="Select transmission type" class="form-control">
      </div>
      <div class="col-md-4">
        <label for="carType" class="form-label">Car Type</label>
        <input type="text" value="Select car type" class="form-control">
      </div>
      <div class="col-md-4">
        <label for="fuelType" class="form-label">Fuel Type</label>
        <input type="text" value="Select fuel type" class="form-control">
      </div>
    </div>
    <div class="row mb-3">
      <div class="col-md-4">
        <label for="seats" class="form-label">Number of Seats</label>
        <input type="text" class="form-control">
      </div>
      <div class="col-md-4">
        <label for="price" class="form-label">Price</label>
        <input type="text" class="form-control">
      </div>
      <div class="col-md-4">
        <label for="carImage" class="form-label">Car Image</label>
        <input type="button" value="Choose File" class="form-control">
        <input type="text" value="No file...hosen" class="form-control">
      </div>
    </div>
    <div class="row mb-3">
      <div class="col-md-12">
        <label for="description" class="form-label">Description</label>
        <input type="text" class="form-control">
      </div>
    </div>
  </form>
</div>
    
```

Figure 14: Add Car Code

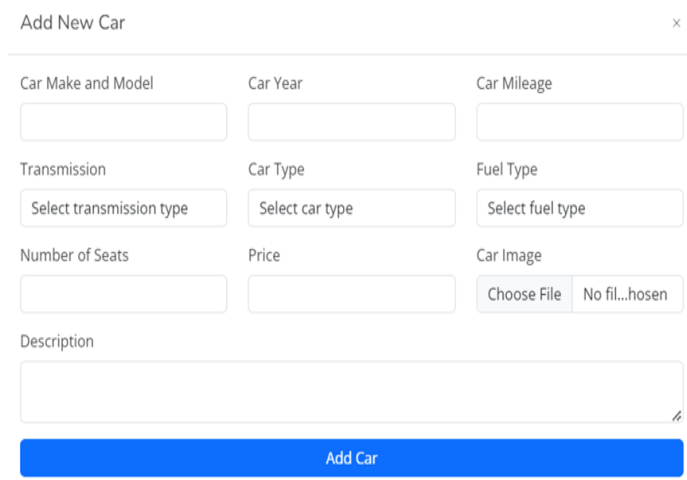

Figure 15: Add Car Page

Figure 16 Shows the interface of reservation, **Figure 17** show the booking details after completing the booking steps.

The reservation interface shows a form titled "Book Blue Chevrolet Coupe Now". It contains four input fields: "Pickup Date" (format dd/mm/yyyy), "Pickup Time" (format --:--:--), "Return Date" (format dd/mm/yyyy), and "Return Time" (format --:--:--). Below these is a "Payment Method" dropdown menu currently showing "Transfer". At the bottom right, there are two buttons: "Cancel" and "Book Now".

Figure 16: Reservation Interface

Booking Details	
Booking ID	DVZP954AN6
Customer Name	test
Car Model	Blue Chevrolet Coupe
Pickup Date	2023-06-19
Pickup Time	20:19:00
Return Date	2023-06-23
Return Time	21:17:00
Payment Method	transfer
Total Amount	400
Payment Amount	0.00
Payment Status	Not Paid Pay Now
Status	Pending

Figure 17: Booking Details Interface

6.2 Testing

The purpose of testing is to demonstrate that the system performs as intended and to identify any issues prior to use. Since different levels of testing strategy have been implemented in various areas of the system, including testing the database and its components, as well as testing interface performance, website usability, and functionality, the testing will help identify error areas and vulnerabilities. There are three primary types of testing discussed in this chapter: the test plan, the test case, and the test results. This system's functionality has been tested throughout the totality of its development.

The functionality of this system has been tested throughout the entirety of the development process. Each function of this system has been tested with all other functions to ensure its operation and to correct both logical and grammatical errors. If there were any problems, they were corrected early enough. However, after the implementation was complete, the system was tested to ensure that it satisfies its requirements and objectives. **Tables 5 – 10** summarize the testing result.

Table 5: Test List of User Interface Process

Test Case ID	Description	Expected Result	Pass/Fail
M1-1	The Customer can enter to the System easily.	Customer can explore the system.	Pass
M1-2	The Customer can make booking	Customer can make booking	Pass
M1-3	The Customer can view booking.	Customer can view the booking details	Pass
M1-4	The Customer can view different type of cars.	The Customer can view different type of cars.	Pass

Table 6: Test List of the Registration and Login Process

Test Case ID	Description	Expected Result	Pass/Fail
M2-1	To check whether customer can register for an account.	The customer should be able to create for an account.	Pass
M2-2	To check whether system will validate user input.	The customer enter the input in registration form.	Pass
M2-3	To check whether a customer can login into the system.	The customer should be able to login into the system.	Pass
M2-4	To check whether the system will restrict login whenever a wrong credential is entered.	The system should restrict login when an incorrect credentials has been entered.	Pass
M2-5	To check whether system will allow redirect the customers to forget password page.	The system should redirect user to forget password page.	Pass

Table 7: Test List for Reservation Process

Test Case ID	Description	Expected Result	Pass/Fail
M3-1	The customer can choose any type of cars	The customer can choose any type of cars	Pass
M3-2	The customer can book	To ensure that customer can book	Pass

Table 8: Test List of the Admin Interface

Test Case ID	Description	Expected Result	Pass/Fail
M4-1	The admin must login before they enter to the system.	Admin can explore the system and manage the reservation	Pass
M4-2	The manager is required to enter a valid username.	The manager can enter a valid username and the login process is successful.	Pass
M4-3	The manager is required to enter a valid password.	The admin can enter a valid password and the login process is successful	Pass
M4-4	The admin can manage all the cars	Admin can add cars, delete, edit, or deactivated.	Pass
M4-5	The admin is able to manage staff.	The admin can add new staff.	Pass
M4-6	The admin is able to manage reservation.	The admin can view reservation of the restaurant	Pass
M4-7	The admin is able to manage customers	The admin is able to manage customers and deactivated their account.	Pass
M4-8	The admin is able to generate report	The admin can generate report on specific date.	Pass

7. Conclusion

The "Al-Wefaq Car Rental Reservation System" project's scheduled processes and tasks have all been successfully finished. It has been determined what the project's scope is. The objectives and their scope are chosen. The literature on construction was investigated. The process for project evaluation and development was described and examined. The project's testing and implementation strategies were successfully carried out. Reporting and project documents are finished. In accordance with the request for further development, the system will also receive further enhancements and functionality.

Acknowledgment

The authors would like to thank the Faculty of Computer Science and Information Technology, Universiti Tun Hussein Onn Malaysia for its support.

References

- [1] Aini, Qurrotul, Syamsuri Nur, and Bayu Wasposito. 2011. "Development Of Car Rental Management Information System." *Proceedings of The 1st International Conference on Information Systems For Business Competitiveness (ICISBC) 2011 Development*: 101–5. <https://www.academia.edu/download/31684635/CarRentalMIS.pdf%0Ahttps://core.ac.uk/download/pdf/11734590.pdf>.
- [2] Sari, Deffi Rosdianac. 2010. "Building Application System Car Rental Reservation and Payment Online Web-Based (Case Study in the Rental Daras Corporation)." 112–116: 1–7.
- [3] Zhongyou, Xing. 2012. "Study on the Application of TOPSIS Method to the Introduction of Foreign Players in CBA Games." *Physics Procedia* 33: 2034–39. <http://dx.doi.org/10.1016/j.phpro.2012.05.320>.
- [4] Helmy, Mohd et al. 2009. "Web Based Intelligent Appointment System." *Seminar Kebangsaan E-Komuniti 2009, Pusat Kajian E-Komuniti, Fssk, Ukm*: 124–36
- [5] Zhongyou, Xing. 2012. "Study on the Application of TOPSIS Method to the Introduction of Foreign Players in CBA Games." *Physics Procedia* 33: 2034–39. <http://dx.doi.org/10.1016/j.phpro.2012.05.320>.
- [6] Aini, Qurrotul, Syamsuri Nur, and Bayu Wasposito. 2011. "Development Of Car Rental Management Information System." *Proceedings of The 1st International Conference on Information Systems For Business Competitiveness (ICISBC) 2011 Development*: 101–5. <https://www.academia.edu/download/31684635/CarRentalMIS.pdf%0Ahttps://core.ac.uk/download/pdf/11734590.pdf>.
- [7] Helmy, Mohd et al. 2009. "Web Based Intelligent Appointment System." *Seminar Kebangsaan E-Komuniti 2009, Pusat Kajian E-Komuniti, Fssk, Ukm*: 124–36.
- [8] Sari, Deffi Rosdianac. 2010. "Building Application System Car Rental Reservation and Payment Online Web-Based (Case Study in the Rental Daras Corporation)." 112–116: 1–7.