

Develop A Prototype of an Unmanned Water Surface Garbage Cleaning Robot Using Photovoltaic Panel

Aiman Fatina Muhamad Kamal¹, Jabbar Al-Fattah Yahya^{1*}

¹Faculty of Electrical and Electronic Engineering,
University Tun Hussein Onn Malaysia, 86400 Parit Raja, Johor, MALAYSIA

*Corresponding Author Designation

DOI: <https://doi.org/10.30880/eeee.2023.04.02.050>

Received 28 June 2023; Accepted 31 July 2023; Available online 31 October 2023

Abstract: The Water Surface Garbage Cleaning Robot (WSGCR) project addresses the problem of water pollution caused by waste accumulation in rivers and other water bodies. Current approaches to cleaning water surfaces often require significant resources and manual labor. Therefore, this project aims to propose an effective solution by developing a WSGCR that can collect waste and increase operational hours through the integration of a photovoltaic (PV) system. The project's objectives encompass the design and development of a small-scale prototype WSGCR and the implementation of the PV system to extend its operation. By leveraging renewable energy sources such as solar power, the WSGCR offers a sustainable and efficient alternative to traditional cleaning methods. Extensive testing and experimentation are conducted to ensure the robot's performance and efficiency, utilizing the Blynk application as an IoT platform for remote control. The WSGCR incorporates a conveyor system for waste collection and motor drivers for precise movement control. The integration of PV panel technology for battery charging is tested and compared to conventional methods. It is found that the PV panel charge rate for an hour is 2.4% rather than using a conventional method which is 3.9%. Also found that by integrating the PV panel the operation of WSGCR for one and a half hours has a decrement of 0.8% rather than using only battery which is 5.47%. The Integrated PV panel has increased operation hours by 4.67% in one and a half hours. Real-time feedback on the robot's functionality is provided through sound indicators using a buzzer in the Blynk interface. The successful realization of this project will contribute to improving water quality, reducing pollution-related health risks, and conserving aquatic ecosystems.

Keywords: Water Surface Garbage Cleaning Robot (WSGCR), Operation Hours, Charging Rate, Photovoltaic (PV) Panel.

1. Introduction

Waste is a chronic pollutant that persists despite ongoing efforts for resolution. It is frequently observed that trash from various sources is dumped into rivers, waterways, and reservoirs, obstructing water flow and causing it to become dirty and odorous. Consequently, this often leads to environmental problems like flooding and pollution. The effects of water pollution are severe, posing significant risks to human health. Waterborne diseases such as diarrhea, trachoma, and hepatitis can be caused by the release of pollutants into waterways [1]. The World Health Organization (WHO) states that 22% of all communicable diseases are waterborne [2]. Aquatic animals are also heavily impacted as their survival relies on water. Excessive algae growth reduces oxygen levels, leading to fish and other aquatic species dying off. Cleaning waste from water areas requires substantial resources, including personnel and excavation equipment [3]. To address these challenges, this project aims to propose an effective solution by developing the Water Surface Garbage Cleaning Robot (WSGCR) that can tackle waste issues in water regions. The objective of the project is to design and develop a prototype and integrate a PV panel to extend its operational hours. The expected outcome is to provide an alternative method for cleaning rivers and enhance their overall cleanliness using this robot.

2. Materials and Methods

Block diagram shown in Figure 1 is the system architecture of the proposed design. The Water Surface Garbage Cleaning Robot (WSGCR) system comprises four main modules: power module, cleaning system, movement system and solar charging system. The robot weighs 9kg and has dimensions of 1.00m (length) x 0.50m (width) x 0.65m (height). The system utilizes an ESP32 microcontroller. The controller is responsible for controlling the motor driver (MDS10), which enables the maneuverability of two sets of thrusters and speed control. The motor driver allows for motor rotation in both anti-clockwise and clockwise directions. Also, the controller is used to control the conveyor system of the water surface cleaning mechanism. The conveyor motor is controlled by the L298N motor driver, which functions similarly to the MDS10 motor driver. Lastly, the system incorporates a photovoltaic (PV) charging system for the robot's battery. Charging is initiated by pushing a button and is regulated by a solar charge controller to prevent overcharging. Overall, the WSGCR system consists of these modules and controllers to facilitate effective garbage cleaning on water surfaces.

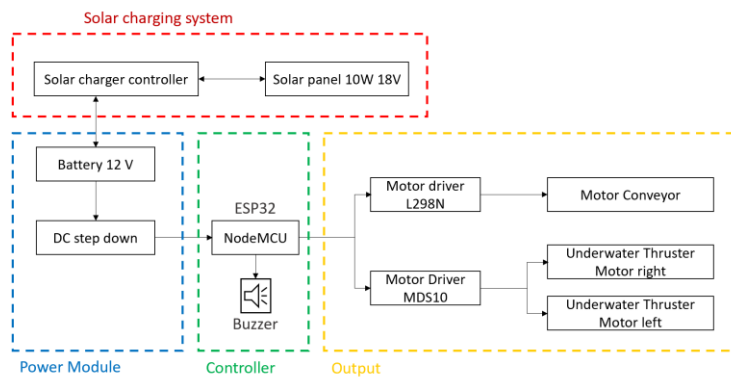

Figure 1: System architecture of the proposed design

Commented [SBS@S1]: Figure 1:

2.1 Materials

Table 1 presents the software and hardware requirements for the Water Surface Garbage Cleaning Robot (WSGCR). The algorithm for controlling the thruster and conveyor was developed using Arduino IDE and integrated into the Blynk application. The robot's design was created using Google Sketchup, and the schematic circuit was drawn using Fritzing. The movement of the robot relies on integrated hardware components, such as the NodeMCU ESP32 microcontroller and a 12VDC Brushed Underwater Motor for the thruster. The cleaning system utilizes a 12VDC 200rpm motor to control the conveyor, powered by a 12V SLA battery with a capacity of 7.0Ah. The charging system is provided by a 10W, 18V Photovoltaic (PV) panel, which harnesses solar energy, while a 10A Solar charge controller is employed to regulate the charging process and prevent overcharging. Motor drivers, including the 10A motor driver (MDS10) for maneuvering the thruster and the motor driver (L298N) for controlling the conveyor motor, are also utilized in the system.

Table 1: Software and hardware requirements

Software	Hardware
a. Arduino IDE	a. NodeMCU ESP32
b. Fritzing Software	b. Conveyor: 12V _{DC} motor, 200 rpm
c. Google Sketchup	c. Thruster: 12V _{DC} Brushed Underwater Motor
d. Blynk App	d. 10W,18V PV panel
	e. 12V 7.0Ah Battery SLA
	f. 10A Solar charge controller
	g. 10A motor driver (MDS10)
	2A motor driver (L298N)

2.2 Algorithm DC motors

Figure 2 depicts the algorithmic code for the DC motor and conveyor movement. Upon turning it on and establishing a Wi-Fi connection, the robot automatically connects to Blynk. Pressing the forward button triggers both thruster motors to rotate anticlockwise, enabling the robot to move forward. Pressing the backward button causes both thruster motors to rotate clockwise, facilitating backward movement. Pressing the left button initiates anticlockwise rotation in one thruster motor and clockwise rotation in the other, enabling the robot to turn left. Pressing the right button triggers a similar action to pressing the left, but with opposite motor rotations, facilitating a right turn. When any button is pressed, the buzzer is activated to indicate if the robot fails to respond. Pressing the conveyor button activates the conveyor belt, allowing it to collect waste effectively.

Commented [SBS@S2]: Adjust to next page.

Commented [SBS@S3]: Table 1:

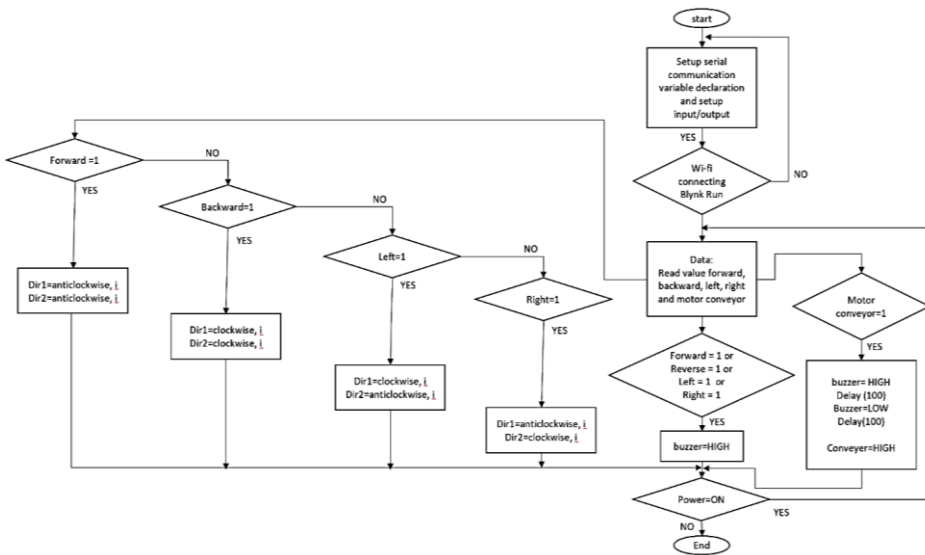

Figure 2: Flowchart for DC motor and motor conveyer

Commented [SBS@S4]: Not clear.
 Commented [SBS@S5]: Figure 2:

2.3 Blynk Application

The Blynk interface, as illustrated in Figure 3, has been programmed with user-friendliness, aiming to provide a seamless and intuitive control experience for operating the robot. By incorporating a visually appealing and interactive design, the interface offers a user-friendly platform that simplifies the control process. Through the Blynk application, users can effortlessly navigate and access various control features and functionalities, enabling them to easily maneuver and command the robot's movements. The intuitive layout and user-friendly controls within the Blynk interface are specifically designed to enhance the overall user experience, making it more convenient and accessible for individuals to control the Water Surface Garbage Cleaning Robot (WSGCR).



Figure 3: Buttons for robot movement

Commented [SBS@S6]: Figure 3:

2.4 Schematic and circuit diagram

To ensure the successful implementation of the project's objectives, meticulous attention is given to establishing proper connections before proceeding to the hardware phase. By prioritizing the correct configuration and interconnection of components, potential issues or errors can be identified and resolved early on. This proactive approach minimizes the risk of hardware malfunctions or compatibility issues, streamlining the subsequent hardware integration process. Ensuring accurate and reliable connections from the outset sets a solid foundation for the WSGCR project, increasing the likelihood of achieving the desired outcomes effectively and efficiently. Figure 4 shows the schematic diagram of the WSGCR.

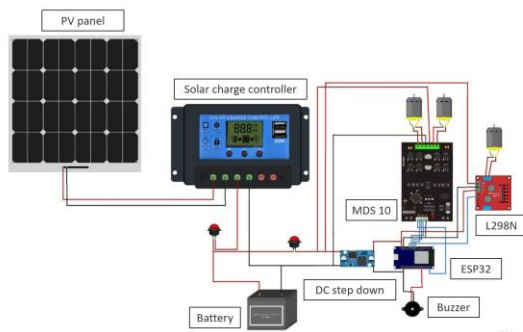

Figure 4: Schematic diagram of the WSGCR.

Commented [SBS@S7]: Figure 4:

3. Results and Discussion

The functionality of the project is examined and assessed through a series of four tests. The first test focuses on evaluating the range and movement capabilities of the robot using the Blynk application. The second test involves assessing the smoothness of waste collection by the conveyor, aiming to determine the types of waste that can be effectively collected. The third test involves analyzing the operational hours. The final test focuses on evaluating the charging rate of the robot, comparing the manual charging method with the charging rate achieved using a PV panel.

3.1 The Water Surface Garbage Cleaning Robot (WSGCR)

The hardware of this project has been developed by referring to the circuit design. Figure 5 shows the overview of the project hardware.

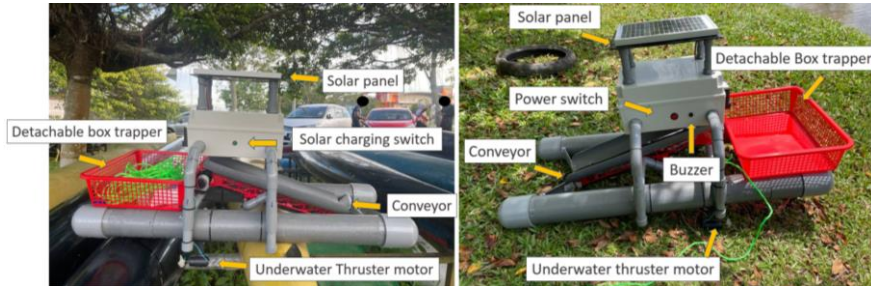

Figure 5: The project hardware

Commented [SBS@S8]: Figure 5:

3.2 Movement of the robot

The robot movement is controlled through the Blynk app using virtual pins connected to buttons, enabling easy navigation of left, right, forward, and backward motions. Additionally, the motor speed can be adjusted using a slider, with a maximum speed value of 255. The conveyor belt, connected to pin 14 (V6) on the microcontroller, can be controlled using a designated button, allowing users to start or stop their movement as needed. Table 2 shows the movement of the robot.

Table 2: Robot movement

Commented [SBS@S9]: Table 2:

Movement	Left Motor	Right Motor
Forward	Anticlockwise	Anticlockwise
Backwards	Clockwise	Clockwise
Right	Clockwise	Anticlockwise
Left	Anticlockwise	Clockwise

3.2.1 Forward Movement

To enable forward movement, both motors need to turn anticlockwise to initiate the forward movement of the robot. The motor turning direction is the same because both thrusters have the same size and shape. Even when the robot is moving forward, it may slightly veer to the right or left depending on the conditions of the water and wind flow. Figure 6(a) illustrates the robot moving forward at a specific speed upon receiving the initial command. To move backward, both motors of the robot rotate clockwise, causing the wheels to move in the opposite direction. Figure 6(b) demonstrates this backward movement initiation using clockwise motor rotation.

Commented [SBS@S10]: Not clear

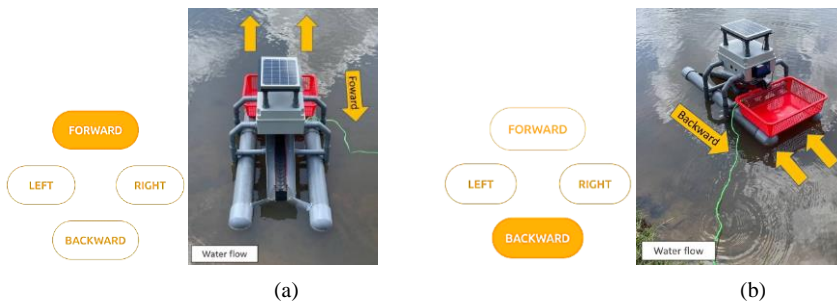

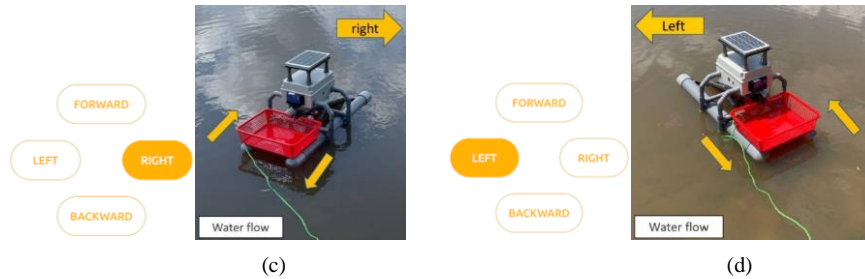

Figure 6: (a) Forward; (b) Backward; (c) Right; and (d) Left movement

To turn left or right, the push and pull concept is applied to enable the robot to move in the desired direction. To initiate the right movement, the left thruster needs to be in the push condition and the right thruster will be in the pull condition, causing the water to flow towards the back. Figure 6(c) illustrates the robot moving to the right. Meanwhile, the right thruster is in the push condition, resulting in the water flow moving towards the front. Conversely, Figure 6(d) demonstrates that the thruster configuration will be reversed for the left movement of the robot, enabling it to move to the left.

3.3 Site Testing

In different environments, the movement and speed of the robot may vary due to variations in flow rates and water characteristics. Table 3 presents data from test sets conducted under consistent movement and distance conditions, with a 20-meter measuring rope used for distance measurement. Only the most accurate data obtained during testing was recorded, including the robot's movement, leakage test results, rubbish collection ability, quantity of rubbish collected, floating test outcomes, and time taken to cover the 20-meter distance.

Table 3: Analysis of data from the experiment

No	Site	G3 Lake UTHM
1	Percentage floating without load	100%
2	Percentage floating with load	95%
3	Weight robot	9KG
4	Leaking	no
5	One rotation (s)	13.12 s
6	Ability to collect waste	Can collect
7	Quantity can collect	6 wastes
8	Distance test (meter)	20 meters
9	20 meters forward (s)	47.25 s
10	20 meters backwards (s)	56.42 s
11	Speed for forward (m/s)	0.42 m/s
12	Speed for backward (m/s)	0.35 m/s
Movement		
13	Forward	straight
14	Backwards	straight
15	Left and right	360° rotations

3.4 Maximum Range and Maximum Size

The first testing method involved using a personal hotspot and a 20-meter measuring rope. During this test, the robot successfully moved up to 20 meters without losing connection to the user. In the

second test, also using the personal hotspot but the measuring rope was not used, and the robot maintained connectivity with the user up to 100 meters. Furthermore, the range can be further extended in areas with excellent network coverage. The cleaning concept of the robot involves the use of a conveyor system to capture waste. The current prototype features a conveyor with a height of 8cm and a diameter of 14cm, allowing it to trap small waste that does not exceed those dimensions. The dimensions of the conveyor part are depicted in Figure 7. Additionally, the current prototype is capable of trapping small and medium-sized waste with a maximum weight of 1kg as shown in Figure 8.



Figure 7: The dimension of the conveyor



Figure 8: Types of waste

Commented [SBS@S11]: Figure 10:

Commented [SBS@S12]: Figure 11:

3.5 Operation hour test

Table 4 presents the obtained data for the comparison of operation hours. This test was conducted over a period of one and a half hours. During this time, the conveyor operated continuously for the entire duration, and the thruster ran at full speed. For the first test, the motor runs only using a battery and for the second test, the robot runs using a battery and a PV panel. While the system is running the PV panel charges the battery. The voltage readings were recorded every 10 minutes throughout the test.

Table 4: Comparison of operation hour

Conditions Time (minute)	Without PV panel		With PV panel	
	Initial Voltage	Voltage after	Initial voltage	Voltage after
0	12.8V	12.8V	12.5V	12.5
10		12.4V		12.6
20		12.4V		12.6
30		12.4V		12.5
40		12.3V		12.3 (cloudy)
50		12.3V		12.5
60		12.3V		12.5
70		12.2V		12.5
80		12.1V		12.4
90		12.1V		12.4

3.5.1 Result Analysis.

According to Table 5, after conducting the test for one and a half hours, the system without using solar energy experienced a significant decrement in operation hours, with a decrement of 5.47%, compared to the system with the integration of a PV panel, which only experienced a decrement of

0.8%. By subtracting the operation hours of both systems, a difference of 4.67% is obtained. This demonstrates that the integration of a PV panel into the system can increase the operation hours by 4.67%.

Table 5: Percentage decrement of voltage

Without PV panel	With PV panel
% Voltage decrement	% Voltage decrement
$= \left(\frac{12.8V-12.1V}{12.8V}\right) \times 100\%$	$= \left(\frac{12.5V-12.4V}{12.5V}\right) \times 100\%$
= 5.47%	= 0.8%
The difference in voltage of the two conditions	
5.47% - 0.8% = 4.67%	

Commented [SBS@S13]: Table 5:

3.6 Charging time test

Table 6 presents the data obtained from the charging time test, which was conducted for a duration of one hour. The robot was charged using two different methods, the first method involved using a battery adapter charger and the second method utilized a PV panel for charging. The circuit diagram of the PV panel is depicted in Figure 9.

Table 6: Comparison of charging time

Time (minute)	Using adapter				Using PV panel			
	Initial Voltage at adapter (V)	Initial Voltage at Solar Charge Controller (V)	Voltage at adapter After (V)	Voltage at Solar Charge controller after (V)	Initial Voltage at adapter (V)	Initial Voltage at Solar Charge Controller (V)	Voltage at adapter After (V)	Voltage at Solar Charge controller after (V)
0	12.7	12.3			12.9	12.4		
50			13.2	12.8			13.2	12.6
60			13.4	12.8			13.2	12.7

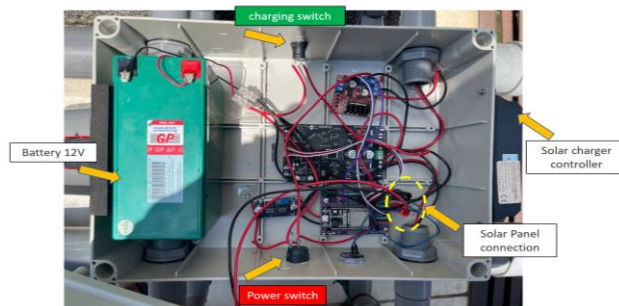

Figure 9: System circuit

Commented [SBS@S14]: Figure 12:

3.6.1 Result analysis.

According to the data presented in Table 7, after one hour of charging, the battery voltage increased from 12.3V to 12.8V when using Method 1 (adapter charging), and from 12.4V to 12.7V when using

Method 2 (PV panel charging). The percentage charging rate for Method 1 is calculated to be 3.9%, while for Method 2 it is 2.4%. Analyzing Table 7, we can conclude that charging the battery using a PV panel is a faster charging rate than using the adapter, with a difference of only 1.50%.

Table 7: Percentage of charging rate

Using adapter	Using PV panel
$= \left(\frac{12.8V - 12.3V}{12.8V} \right) \times 100\%$	$= \left(\frac{12.7V - 12.4V}{12.7V} \right) \times 100\%$
= 3.90%	= 2.40%
The difference in voltage of the two conditions	
3.90% - 2.40% = 1.50%	

4. Conclusion

In conclusion, the Water Surface Garbage Cleaning Robot project has successfully met its objectives of designing and developing a functional robot prototype and increasing its operation hours through the integration of a Photovoltaic (PV) system by 4.67% for one and a half hours. By harnessing solar energy, the system's dependency on traditional charging methods was reduced, allowing for extended operation without the need for constant manual charging. The PV panel charge rate for an hour is 2.4% rather than using a conventional method which is 3.9%. The design phase of the project focused on creating a compact and efficient robot that could effectively collect garbage from water surfaces. By considering factors such as size, weight capacity, and maneuverability, the project team successfully designed a robot that meets these requirements. During the development phase, a functional prototype of the Water Surface Garbage Cleaning Robot was built. This involved integrating various components such as motors, conveyors, and control systems to ensure the robot's proper functionality. The project's achievements contribute to addressing the challenge of water pollution by providing an efficient and sustainable solution for garbage collection on water surfaces.

Acknowledgement

The authors would like to thank the Faculty of Electrical and Electronics Engineering, Universiti Tun Hussein Onn Malaysia for its support.

References

- [1] Mullen, K. Information on Earth's Water. NGWA the groundwater association | what is groundwater | [online] | <https://www.ngwa.org/what-is-groundwater/aboutgroundwater/information-on-earths-water>.
- [2] Savitri P A, Purba W S and Zulkifli M | (2018) | Pengelolaan Sampah di Indonesia Statistik Lingkungan Hidup Indonesia. Badan Pusat Statistik | [online] | <https://www.bps.go.id/publication/2018/12/07/d8cbb5465bd1d3138c21fc80/statistik-lingkungan-hidup-indonesia-2018.html>.
- [3] Rahmawati, Endah & Suchayo, Imam & Asnawi, Asnawi & Faris, M & Taqwim, M & Mahendra, D | (2019) | A Water Surface Cleaning Robot | [Journal] | Journal of Physics: Conference Series. 1417. 012006. 10.1088/1742-6596/1417/1/012006.