

Development of Multiple Input Battery Charger for Electric Bicycle Application

Yeak Zu Yuan¹, Zarafi Ahmad^{1*}

¹ Department of Electrical Engineering, Faculty of Electrical and Electronic Engineering,
Universiti Tun Hussein Onn Malaysia, 86400 Parit Raja, Johor, Malaysia

*Corresponding Author: zarafi@uthm.edu.my

DOI: <https://doi.org/10.30880/eeee.2024.05.02.024>

Article Info

Received: 30 June 2024

Accepted: 1 October 2024

Available online: 30 October 2024

Keywords

Battery charger, Multiple input, Solar energy

Abstract

The multiple input battery charger for electric bicycle applications represents a significant advancement in energy storage technology. This innovative charger is designed to accommodate various power sources, including solar, and conventional AC power (utility), enhancing the versatility and convenience of electric bicycles. By optimizing efficiency and maintaining battery health, it ensures longer operational lifespans. Its flexibility makes it suitable for diverse charging scenarios, from urban environments to remote and off-grid locations. Efficiently managing and prioritizing different energy inputs, the charger supports the use of renewable energy and improves energy security and sustainability. This technology allows electric bicycle users to charge their batteries from multiple sources, ensuring that they can keep their bicycles powered regardless of their location. In urban areas, users can easily switch between grid power and renewable sources like solar panels. As the demand for eco-friendly transportation increases, this multiple input battery charger is poised to play a vital role in promoting the widespread adoption of electric bicycles. It contributes to reduce carbon emissions and advances sustainable urban mobility solutions, making it a key component in the evolution of electric bicycle technology and fostering energy independence and resilience in the face of environmental challenges.

1. Introduction

An electric bicycle (e-bike) combines traditional cycling with the convenience of an electric motor, providing an enhanced mode of transportation. Equipped with a rechargeable battery, e-bikes offer varying levels of pedal assistance, making it easier to tackle hills and long distances. Some models also feature a throttle for motor-powered movement without pedaling, akin to a motorcycle. E-bikes are environmentally friendly, emitting no greenhouse gases and thus serving as a sustainable commuting option. Their growing popularity can be attributed to their convenience, affordability, and appeal to a diverse range of users, from those seeking a less strenuous cycling experience to individuals looking for a practical alternative to cars for short trips. E-bikes also alleviate road congestion by enabling riders to use sidewalks, reducing traffic jams.

In China, e-bikes are particularly popular due to their affordability compared to cars, making them accessible to middle and low-income consumers. Government incentives like subsidies and tax breaks further promote e-bike adoption. E-bikes address first-mile and last-mile transportation needs, enhancing the utility of public transit systems. The establishment of dedicated cycling lanes and e-bike parking spaces has improved their practicality and safety for daily commuting. Additionally, rising awareness of health and fitness has

boosted the appeal of e-bikes, as they incorporate physical activity into daily routines. Thus, e-bikes offer a versatile solution, complementing public transit and providing an inclusive and practical alternative for short-distance travel [1].

As e-bikes become more prevalent, charging infrastructure becomes crucial. They can be charged at home with an e-bike charger or at public charging stations, but both methods rely on utility power, which can be inconvenient during outages. Solar charging stations present a more environmentally friendly alternative, offering benefits such as cost-effectiveness over time, portability, and a long lifespan of up to 25 years for solar panels. They provide the convenience of charging on the go without needing electrical outlets. However, their effectiveness depends on sunlight, making them less efficient in cloudy or shaded areas, and the initial investment can be high. Despite these limitations, the advantages of solar power generally outweigh the disadvantages. This study aims to explore e-bike charging methods and develop a charger that supports both utility and solar energy inputs, promoting sustainability and reducing carbon footprints [2].

This project aims two main objectives which are: 1) To develop a battery charger with multiple input sources (utility and solar energy) for electric bicycle application, 2) To evaluate the safety features of the battery charger such as undervoltage protection to ensure safety operation.

2. Materials and Method

This project develops multiple input (utility and solar energy) battery charger. The first phase focuses on studying the battery charger requirements and conducting a literature review to understand the necessary hardware. A system plan for the battery charger is then developed and presented. In the second phase, the battery charger is developed and subjected to experimental testing. Based on feedback from the first phase, necessary modifications are made before assembling and installing the hardware. The system is then tested in the laboratory, and the collected data is analyzed to assess performance and validate the methodology. This structured approach ensures a systematic and successful execution of the project from start to finish.

The block diagram depicted in Fig.1 illustrates the battery charger that needs to be developed. The solar panel connected to the inverter, the inverter is connected to smart MCB and the smart MCB is connected to the normal power (main supply) of the ATS. The electricity comes from utility is connected to a MCB and the MCB is connected to the emergency power (back-up power) of the ATS. The output of the ATS is connected to a rectifier which will transform AC to DC to charge the battery. When the power supply by the PV panels is lower or higher than pre-set value of smart MCB, the smart MCB will cut off the current form PV panels and ATS will be switched to use the electricity from the utility to charge the battery of the electric bicycle. When the supply from PV panels is back to normal, the ATS will switch back to use the supply from PV panels.

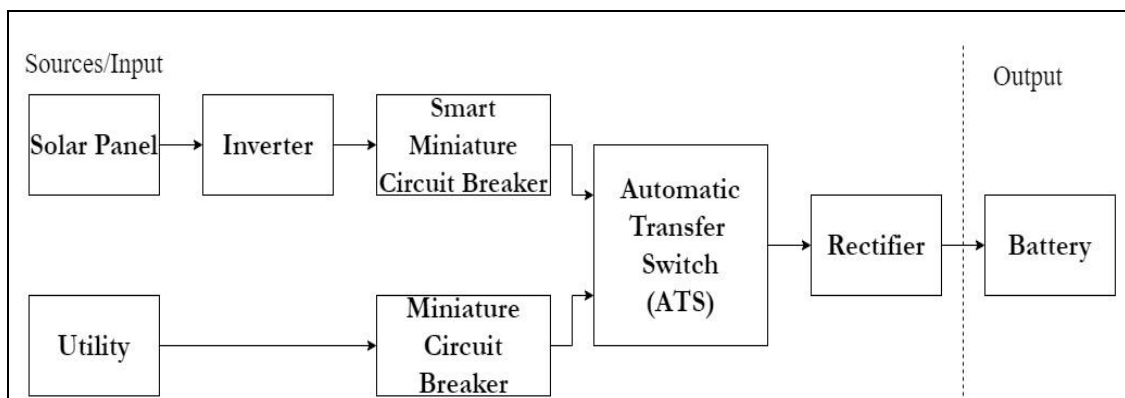

Fig. 1 The battery charger that needs to be developed

2.1 Hardware and Software Used

The hardware components selected for the project include Miniature Circuit Breakers (MCBs), Smart MCBs, Automatic Transfer Switches (ATS), and Polyvinyl Chloride (PVC) Insulated Copper Wire. The MCBs are used to automatically cut off electrical current during abnormal conditions, such as overloading, to enhance safety. When the current exceeds its rated limit, the MCB will disconnect the circuit. The Smart MCBs offer additional features like monitoring and control capabilities via Wi-Fi, ensuring protection against overcurrent and undercurrent [3]. The ATS is designed to seamlessly shift the power supply from the main source to a backup source, such as a UPS or generator, ensuring uninterrupted power supply. Acting as an intermediary between both primary and backup power sources, the ATS facilitates the transition between equipment and power supplies by functioning as an electrical relay [4]. Copper wire has high conductivity for efficient electricity transfer, high ampacity which can carry large amounts of current without overheating and resistance to

corrosion. Cross sectional area of 2.5 mm² copper wire is chosen to be used due to its adequate current carrying capacity, reduced voltage drops, enhanced safety, durability, and versatility for various electrical loads [5].

The software used in this project is SMART LIFE application. This application is a smart home application that allows to connect and control all smart devices in home by connecting it to Wi-Fi. The application is used to control the smart MCB in this project. When the smart MCB is connected to the Wi-Fi, the application can be used to set the overvoltage and undervoltage protection for the devices in which the smart MCB will trip when the voltage level is fell below or rise above the set value.

2.2 Hardware Layout

The hardware for the project was installed as depicted in Fig. 2. The devices used include a 63A MCB, a smart MCB, and an ATS, with red and black PVC-insulated copper wires indicating live and neutral connections, respectively. Upon connecting both MCBs to the power supply, the smart MCB was activated and linked to a private Wi-Fi network. This setup allows the status of the breaker to be monitored either through the smart MCB's screen or via the Smart Life mobile application. Using the application, undervoltage and overvoltage alarms were configured to protect the rectifier, which operates within a voltage range of 180V to 240V. The undervoltage alarm was set to trigger at 170V, and the overvoltage alarm at 250V. Once these alarms are set, any instance of undervoltage will prompt a notification to the owner.

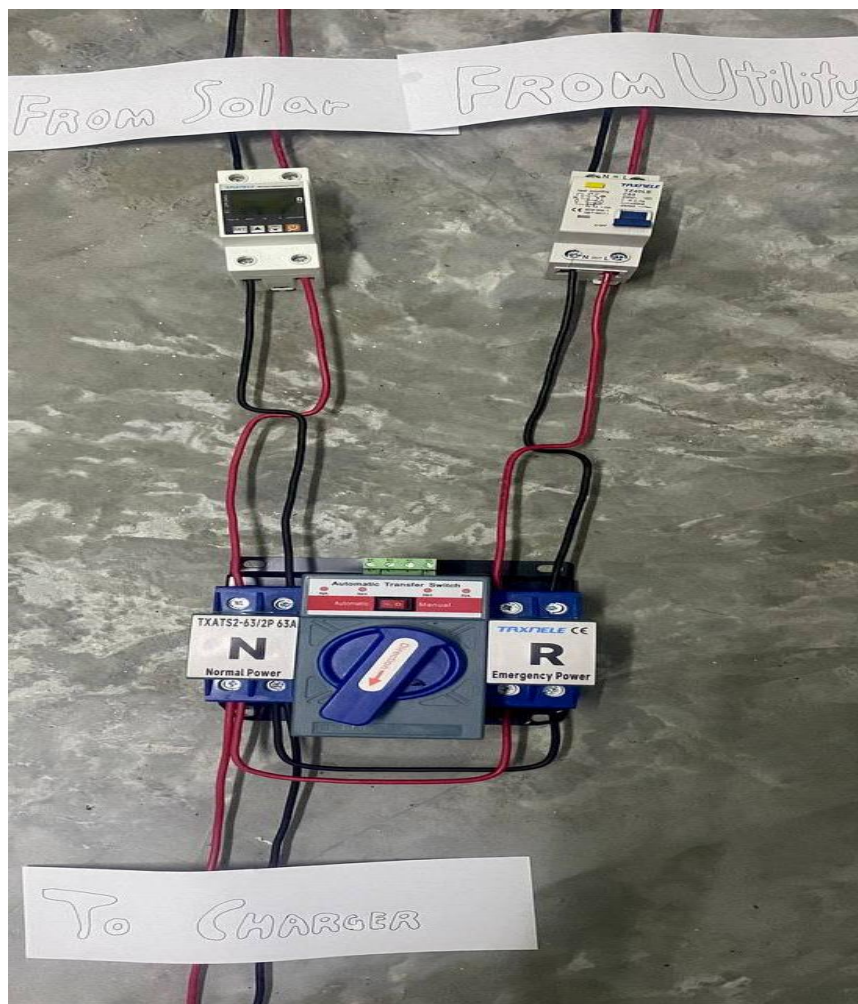

Fig. 2 Hardware of the project

2.3 Safety Feature Testing

Safety features of the battery charger are tested by connecting the main supply to a variable AC source. The rectifier is designed to handle input voltages between 180V and 240V, converting it to a 54.6V DC output. The testing simulates conditions like cloudy or rainy days that cause lower voltage levels, ensuring the charger operates effectively under varying conditions.

3. Results and Discussion

This section describes the result of testing of the hardware with solar panel and variable AC/DC supply. The testing is done at block F1 Basic Machinery Laboratory and block G1 Transportation Laboratory in Universiti Tun Hussein Onn Malaysia (UTHM).

3.1 Testing with solar panel

The existing solar panels on the roof of the Basic Machines Laboratory in F1 were arranged in groups of four, each controlled by an inverter, with each panel providing 80W. The charger was connected to the solar panel's inverter. When the charger was integrated into the system, the smart MCB activated, maintaining a stable input voltage of 233V. To test undervoltage conditions, the PV panels (the primary input) were switched off, but the input voltage remained stable at 233V. This stability was due to the fully charged battery in the solar system supplying power to the smart MCB. Since the system's output voltage was preset to around 230V-240V and the battery was fully charged, the overvoltage or undervoltage conditions cannot be tested. The integrated system configuration prevented the battery from being removed for further testing.

3.2 Testing with variable AC/DC supply

The testing is then conducted in Transportation Laboratory by connecting the main supply to the variable AC/DC supply. The purpose of using AC/DC supply is to simulate the situation faced by solar panel which is cloudy day and rainy day which will cause the solar panel cannot provide sufficient voltage thus will cause undervoltage situation to be occurred. The testing is also to test the safety features of the battery charger. The main supply of the battery charger is connected to variable AC/DC supply and the variable AC/DC supply is connected parallel to a digital multiple for measuring the output voltage of the supply. The variable AC/DC supply can deliver a maximum of 250V but due to the aging of the equipment, the maximum voltage that can be delivered is about 236V to 237V as shown in Fig. 4.

When the charger is connected to variable ac/dc supply, the system will function as normal when the input voltage is adjusted above the preset undervoltage value, which is 170V. When the input voltage is adjusted lower than 170V, the smart MCB will trip and the ATS will switch to use the supply from utility for continuous supply the load. When the main supply is in undervoltage condition, the voltage supply is not sufficient and thus causes damage to the rectifiers. Fig. 5 shows the input voltage was set at below 170V and the ATS switch to use the electricity from the utility as indicated by Light Emitting Diode (LED) on the right side of the ATS.

When the input voltage is adjusted higher than undervoltage value 170V, the smart MCB will take 10s to allow the current to flow through. This is due to its safety mechanisms and recovery delay. After the undervoltage is resolved and the voltage returns to normal, the MCB intentionally delays restoring current flow. This delay ensures that the system stabilizes before allowing electricity through. During this delay, the MCB checks for any transient voltage fluctuations or other issues that might affect system stability. The testing involved the testing of safety features of the battery charger to avoid any dangerous situations occurring. When the voltage level back to normal, which is between 180V to 240V, the ATS will switch back to use the supply from the variable ac/dc supply. For overvoltage condition, the maximum voltage for the variable ac/dc supply is lower than 250V. As the preset value of smart MCB for overvoltage is 250V, the testing cannot be done as the maximum voltage for variable ac/dc supply is lower than preset value.

3.3 Testing of the Rectifier

The rectifier used in the experiment with the specifications of input voltage 180VAC to 240VAC and the output voltage of 54.6VDC. The output of the rectifier is connected to multimeter for testing as shown in Fig 6.

In Fig. 6, the observed value of the output of the rectifier is 55.24VDC which is higher than expected value. This may be due to inefficient filtering, such as oversized filter capacitors, can reduce ripple and retain peak voltage, resulting in higher DC output. Besides, voltage regulation issues, including malfunctioning or improperly set regulators, can lead to increased voltage levels and component tolerances and temperature effects can also cause variations, with components like diodes having lower forward voltage drops at higher temperatures. Additionally, if the battery or load draws less current than anticipated, the voltage drop across the rectifier's internal resistance will be lower, resulting in a higher output voltage.

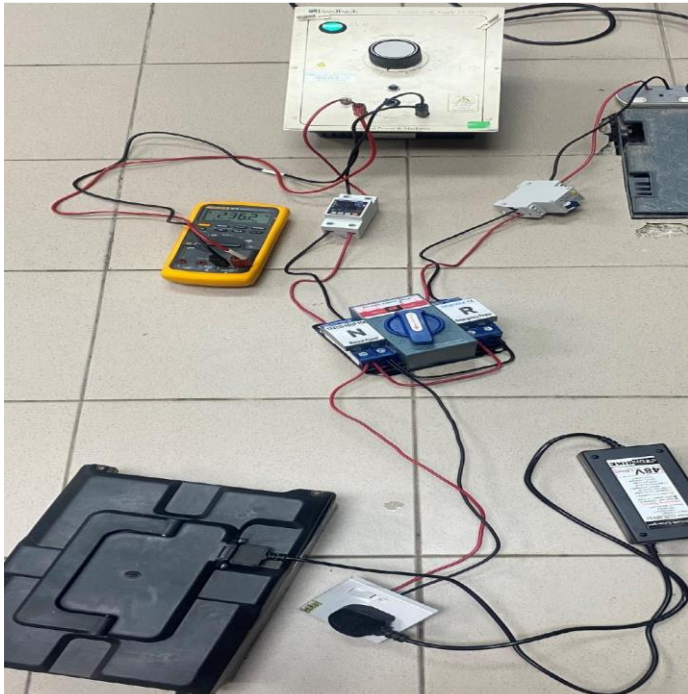

Fig. 4 Battery charger is connected to variable AC/DC supply

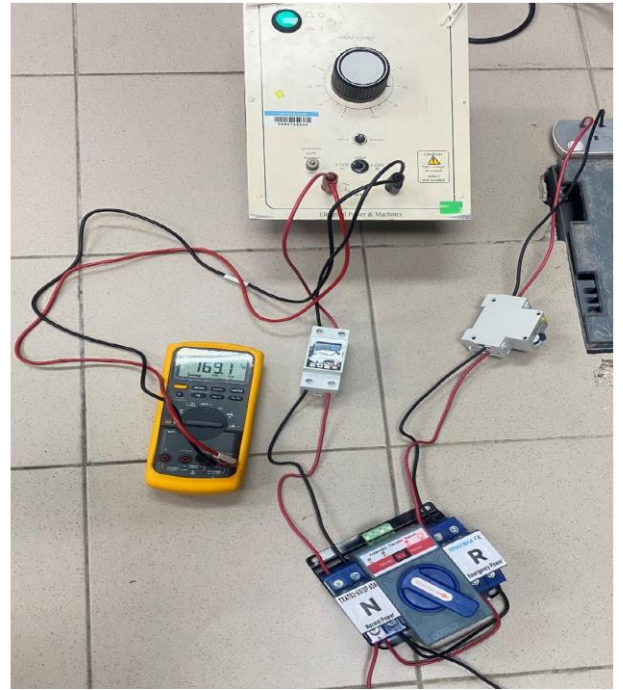

Fig. 5 The input voltage was set at below 170V

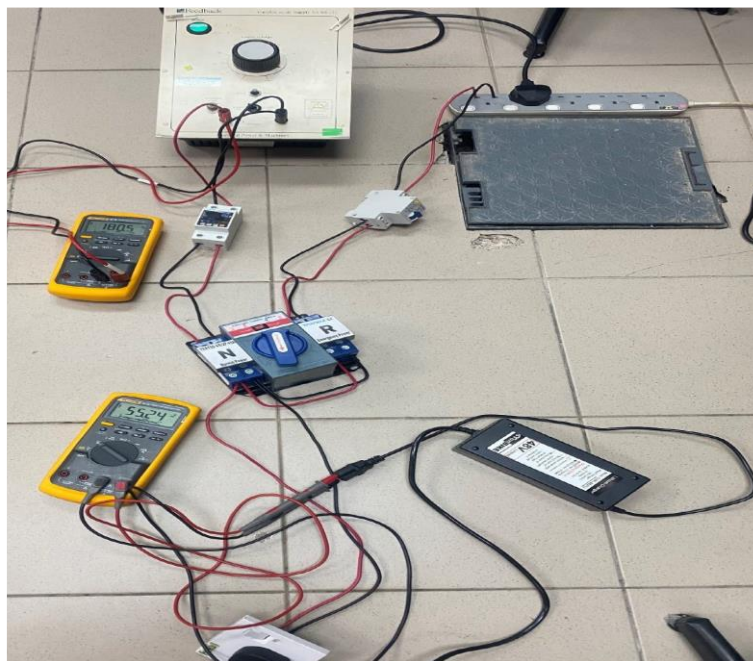

Fig. 6 Connection of testing of rectifier

3.4 Testing with Load (Battery)

The output, which is 48V lithium-ion battery is connected to the battery charger. The reading of the battery is tested with the multimeter. The reading of the battery before charging is 45.44V as shown in Fig. 7. The reading of the battery after charging by the charger is 46.84V as shown in Fig. 8. The readings of 45.44V before charging and 46.84V after charging suggest that the battery has gained some charge from the charger but is not yet fully charged. This is typical behavior for a battery that has been on charge for a short duration. The battery charger is tested to be compatible with the load which is 48V lithium-ion battery.



Fig. 7 The reading of the battery before charging



Fig. 8 The reading of the battery after charging

4. Conclusion

This project successfully developed a multiple input battery charger for e-bikes, leveraging both utility power and solar energy. The implementation of smart MCBs, ATS, and the integration with a private Wi-Fi network allowed for efficient monitoring and control via the Smart Life mobile application. The charging system demonstrated effective protection against voltage fluctuations, with alarms set for undervoltage and overvoltage conditions to safeguard the rectifier. The project validated that solar charging is a viable and environmentally friendly alternative to traditional charging methods, potentially reducing carbon footprints and promoting sustainable transportation.

Future work should focus on enhancing the efficiency and accessibility of solar charging stations. Research could explore advanced solar panel technologies to improve performance in cloudy or shaded environments, and cost-effective solutions to lower the initial investment for users. Additionally, expanding the smart features of the charger, such as incorporating predictive maintenance and remote troubleshooting capabilities, could further improve user experience and system reliability. Collaboration with government and private sectors to increase the availability of public solar charging stations and to promote the adoption of e-bikes through incentives would also be beneficial. Continued innovation and support in this field are essential to advancing sustainable and efficient urban transportation solutions.

Acknowledgement

The authors would like to thank the Faculty of Electrical and Electronic Engineering, Universiti Tun Hussein Onn Malaysia for its great deal of support.

Conflict of Interest

Authors declare that there is no conflict of interests regarding the publication of the paper.

Author Contribution

*The authors confirm contribution to the paper as follows: **study conception and design:** Yeak Zu Yuan; **data collection:** Yeak Zu Yuan; **analysis and interpretation of results:** Yeak Zu Yuan; **draft manuscript preparation:** Yeak Zu Yuan, Md Zarafi Ahmad. All authors reviewed the results and approved the final version of the manuscript.*

References

- [1] A. Bigazzi and K. Wong, "Electric bicycle mode substitution for driving, public transit, conventional cycling, and walking," *Transportation Research Part D: Transport and Environment*, vol. 85, p. 102412, 2020. doi: 10.1016/j.trd.2020.102412.
- [2] Energy5 Your Way, "Charged Up: Pros and Cons of Solar Charging Stations for Your E-Bike," 2023. [Online]. Available: <https://energy5.com/charged-up-pros-and-cons-of-solar-charging-stations-for-your-e-bike>.

- [3] "Smart MCB." [Online]. Available: <https://smarden.in/smart-mcb/> [Accessed: June 5, 2024]
- [4] T. Culverhouse, "Automatic transfer switch (ATS)," TechTarget, Feb. 2017. [Online]. Available: <https://www.techtarget.com/searchdatacenter/definition/Automatic-transfer-switch-ATS> [Accessed: June 5, 2024]
- [5] "Pros and cons of copper and aluminum wire," Regency Supply Insights. [Online]. Available: <https://insights.regencysupply.com/pros-and-cons-of-copper-and-aluminum-wire> [Accessed: June 5, 2024]