

Air Quality Monitoring System using IoT

Nurul Syahidah Razak¹, Mariyam Jamilah Homam^{1*}

¹ Department of Electronic Engineering, Faculty of Electrical and Electronic Engineering
Universiti Tun Hussein Onn Malaysia, Batu Pahat, 86400, Johor, MALAYSIA

*Corresponding Author: mariyam@uthm.edu.my

DOI: <https://doi.org/10.30880/eeee.2024.05.02.015>

Article Info

Received: 11 July 2024

Accepted: 11 September 2024

Available online: 30 October 2024

Keywords

Air Quality Monitoring, Internet of Things (IoT), Long Range Module (LoRa) Sensors, Real-time Monitoring

Abstract

Air pollution originating from vehicles and industries has become a serious problem posing a threat to human life. Therefore, air quality monitoring is crucial for both outdoor and indoor applications to safeguard a promising future and ensure a healthier life. This project developed an air quality monitoring system that allows users to monitor and examine air quality directly at a specific location using the Internet of Things (IoT). The system employs two types of sensors: fine dust sensor (GP2Y1010AU0F) and temperature with humidity sensor (DHT11) which transmit data to NodeMCU ESP32. This microcontroller processes and sends the data to the Blynk web server. The project also incorporates Long Range (LoRa) module as the transmitter and receiver for the sensor data. Results are compared with TESTO 650i. There were some inconsistencies with readings which could be due to sensors' accuracy or environmental factors. The integration of this system with cloud storage enhances the efficiency of information delivery. An IoT-based system like this is essential for users who wish to conduct real-time remote monitoring. Ultimately, this project serves as a method to detect fine dust and monitor air quality readings including temperature and humidity.

1. Introduction

Air pollution has emerged as one of the most pressing environmental issues, significantly impacting health and the environment [1]. Traditional air quality monitoring methods face challenges such as high costs and lack of real-time data [2]. The Internet of Things (IoT) offers a cost-effective solution by enabling real-time data collection and analysis [3]. This project proposes an IoT-based air quality monitoring system using GP2Y1010AU0F fine dust sensor and the DHT11 temperature and humidity sensor, transmitting data to an NodeMCU ESP32 microcontroller and then to the Blynk web server for real-time monitoring [4]. The system also incorporates LoRa module to enhance transmission range. This IoT-based solution provides an efficient, scalable method for air quality monitoring, addressing the limitations of traditional methods and contributing to efforts in mitigating air pollution's adverse effects [5].

2. Methodology

Fig. 1 shows the block diagram for LoRa transmitter. The system begins with the DHT 11 sensor and the Sharp Dust GP2Y1010AU0F sensor sending data to the NodeMCU ESP32 microcontroller. Temperature and humidity data are sent by the DHT 11 sensor, while particulate matter data is sent by the Sharp Dust sensor to the NodeMCU ESP32. The data is then transmitted to the LoRa Transmitter, and subsequently, the data is sent to the Blynk Cloud. Fig. 2 shows the block diagram for LoRa Receiver. LoRa Receiver receives data transmitted over

LoRa network. The NodeMCU processes the received data from the LoRa module and formats it for transmission to the Blynk cloud and LCD. The data is then stored in the Blynk Cloud and displayed on the LCD.

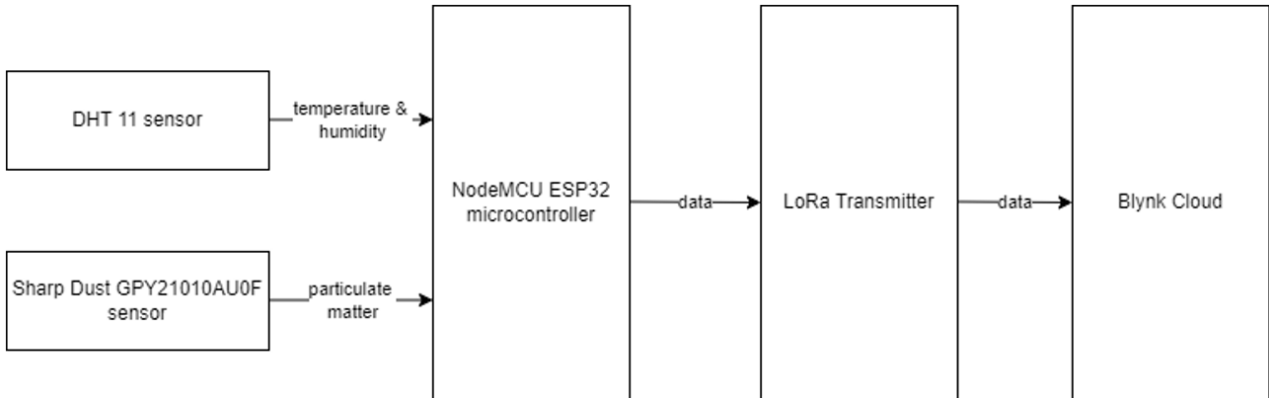

Fig. 1 The block diagram for transmitter

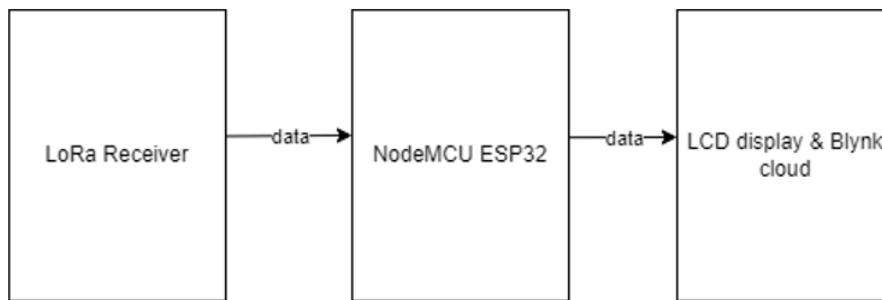

Fig. 2 The block diagram for receiver

Fig. 3 shows the flowchart for the operation of the air quality monitoring system. Initially, the system is started, and it is checked if power is received from the power bank. Once powered, data on temperature, humidity, and particulate matter are transmitted from two separate locations: Location 1 (Tun Fatimah (TF) College) and Location 2 (Tunku Tun Fatimah Library (PTTA)).

The NodeMCU ESP32 microcontroller with LoRa is then activated, and it is connected to Wi-Fi and the Blynk application. This setup allows data to be received from both locations. The collected data are stored in the Blynk application and displayed on an LCD screen.

The system uses a DHT11 sensor to measure temperature in degrees Celsius and humidity in percentage, and a GP2Y1010AU0F dust sensor to measure particulate matter in micrograms per cubic meter. These sensors operate autonomously at the specified locations. The sensor data are easily retrieved and transmitted using NodeMCU ESP32 and LoRa. All the collected data are carefully stored in the Blynk application, which is easy to use. Fig. 4 shows the prototype of the transmitter and Fig. 5 shows the prototype of the receiver.

Table 1 lists all the components needed for this project. Whilst, Table 2 shows the software requirement for the project and the purpose of the software in the project development.

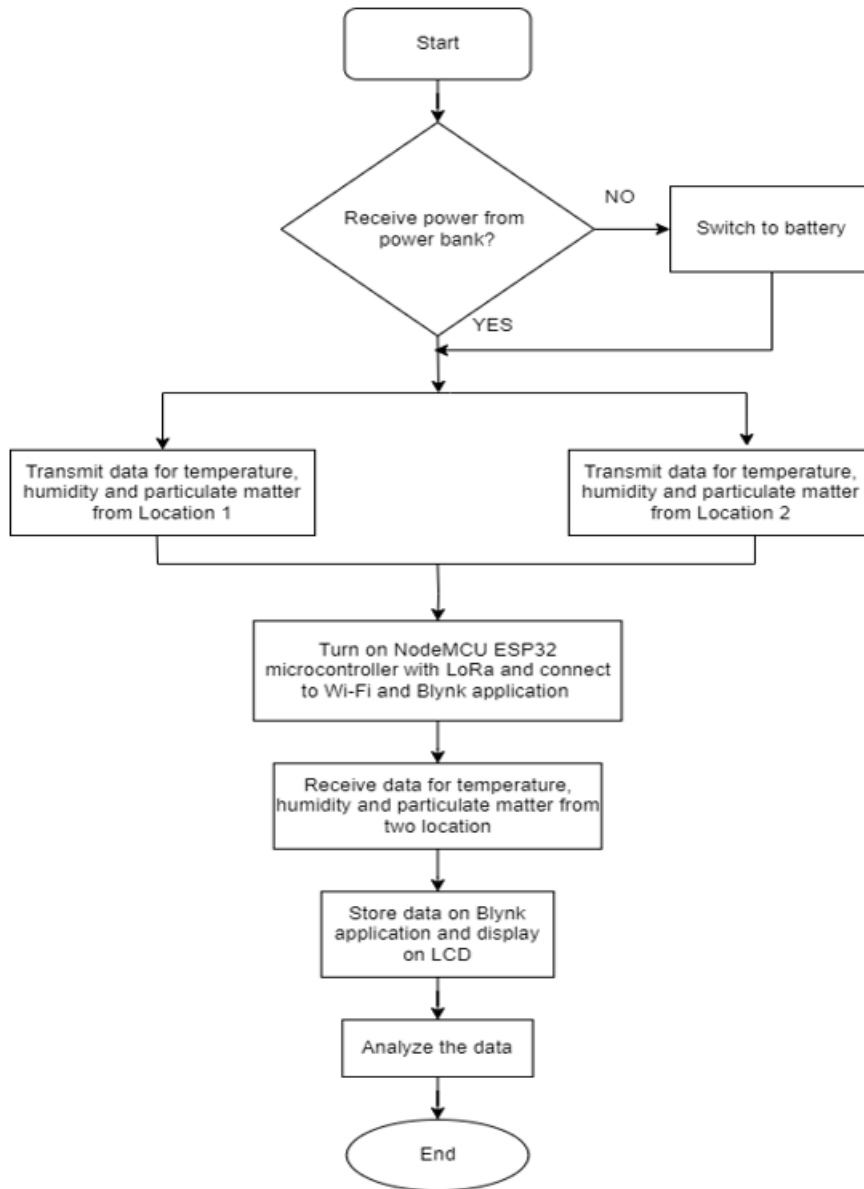

Fig. 3 Flowchart of overall project

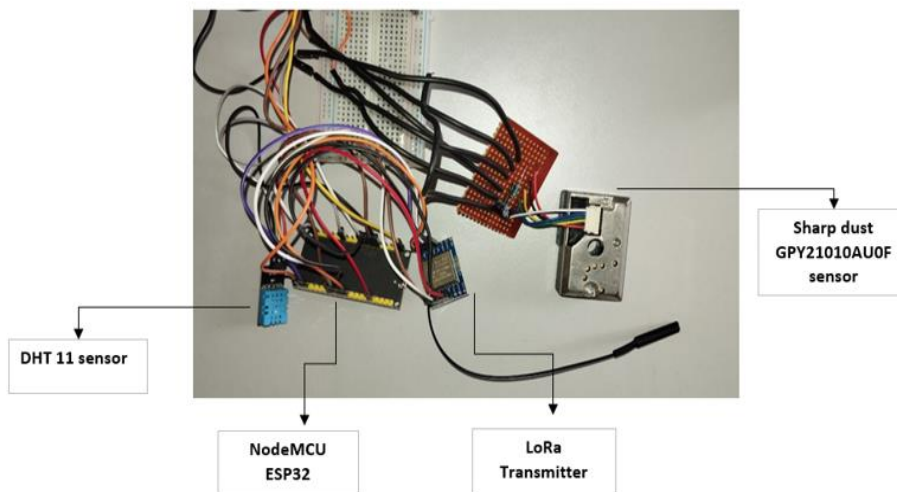

Fig. 4 Prototype of the transmitter

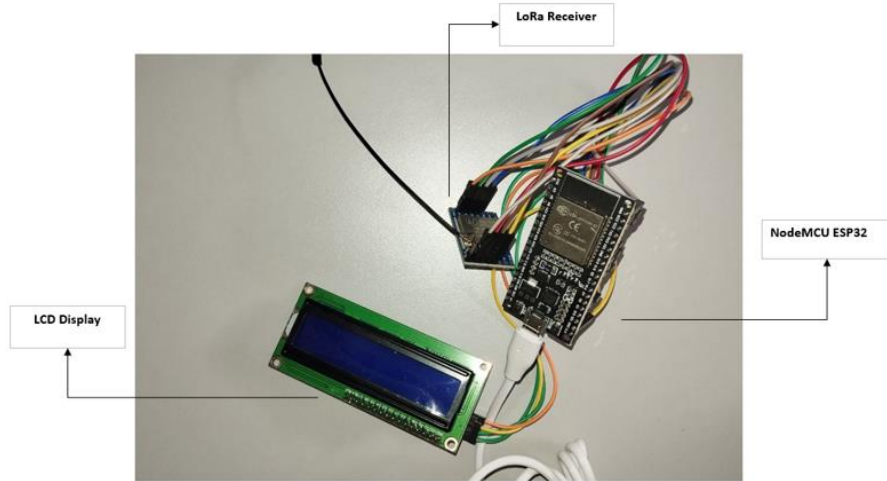

Fig. 5 Prototype of the receiver

Table 1 List of components and their functions

No	Components	Function
1	NodeMCU ESP32 microcontroller.	Primary microcontroller.
2	DHT 11 sensor.	Measure temperature and humidity.
3	Sharp dust GP2Y1010AU0F sensor.	Measure particulate matter (dust).
4	Longe-Range (LoRa) module.	Act as transmitter and receiver of the data.

Table 2 Software requirements and the purpose

No	Software	Function
1	AEDUINO IDE.	For programming the code and uploading the code into the microcontroller.
2	Blynk Cloud	Act as transmitter and receiver of the data.

3. Result and Analysis

Fig.6 shows the prototypes of the transmitters at both locations. In Fig. 6(a), the temperature, humidity, and particulate matter are tested at TF College while in Fig. 6(b) are tested at PTTA. Fig. 6(c) shows the data stored in Blynk Cloud that synchronized with the LCD in Fig. 6(d) and Fig. 6(e). That means the data sent by LoRa transmitter is stored in Blynk Cloud and displayed on the LCD. Fig. 6(d) and Fig. 6(e) show the results that are displayed on the Blynk Cloud and the LCD respectively.

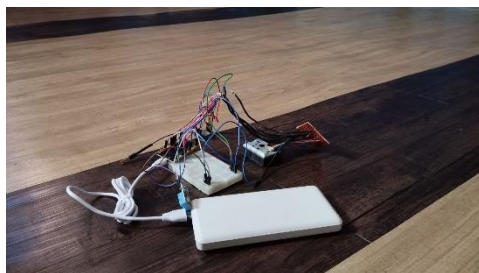

Fig. 6(a) Transmitter at TF College

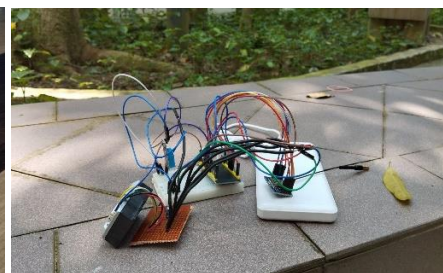

Fig.6 (b) Transmitter at PTTA

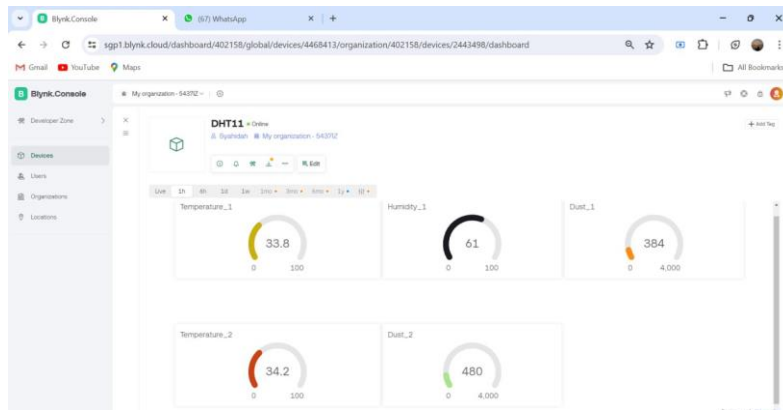

Fig. 6(c) Data stored in Blynk Cloud are synced with the data on LCD



Fig. 6(d) Data for temperature, humidity, and particulate matter displayed at TF College



Fig. 6(e) Data for temperature, humidity, and particulate matter displayed at PTTA

3.1 Comparison with TESTO 650i

result from the project is compared with TESTO 650i to determine which method is more effective, accurate, or suitable for a particular task. Fig. 7(a) shows the average temperature for TF College. The values measured by TESTO 650i and DHT 11 are not very much different. Fig. 7(b) shows the average humidity for TF College. In the morning, the result taken by TESTO 650i is higher than DHT 11, while at night the value is almost the same. Fig. 7(c) shows the temperature for PTTA. The TESTO 650i recorded significantly higher humidity levels in the morning compared to the DHT 11. However, during the night, the humidity levels measured by both sensors were almost identical. This suggests potential differences in sensor sensitivity or environmental conditions affecting the measurements. Fig. 7(d) shows the average humidity for PTTA. The humidity levels measured by both sensors in the morning were quite similar, with the TESTO 650i recording a slightly higher value. During the night, the DHT 11 sensor recorded a marginally higher humidity level than the TESTO 650i. This indicates that the measurements from both sensors are consistent, with minor variations possibly due to sensor accuracy or environmental factors.

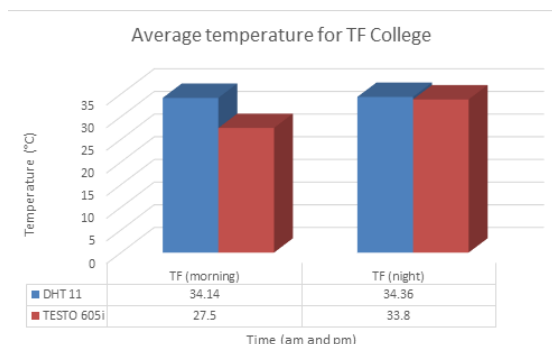

Fig. 7(a) Average temperature for TF College

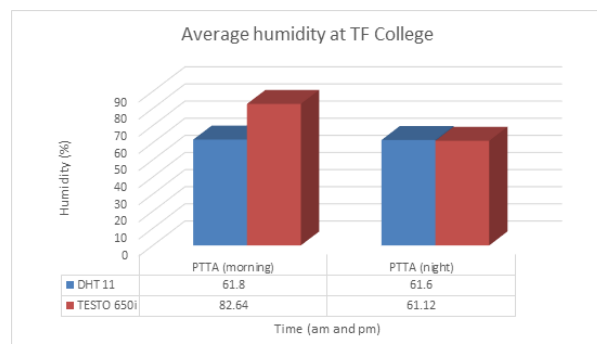

Fig. 7(b) Average humidity for TF College

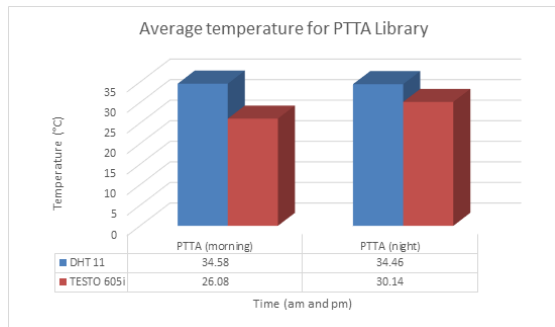

Fig. 7(c) Average temperature for PTTA

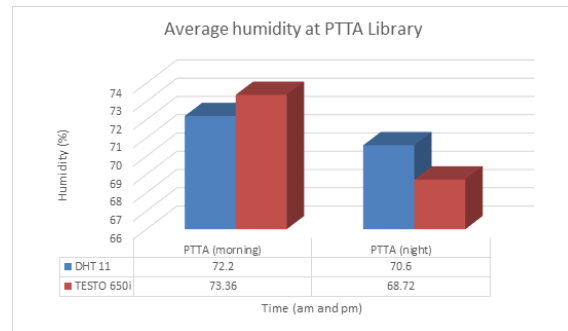

Fig. 7(d) Average humidity for PTTA

4. Conclusion

This project developed a portable air quality monitoring system using the NodeMCU ESP32 microcontroller, Sharp dust sensor GP2Y1010AU0F, and DHT11 sensor to measure particulate matter, temperature, and humidity. Comparison with TESTO 650i yields some differences in temperature and humidity and some inconsistencies were noted in particulate matter readings. Integrating the system with an IoT platform using LoRa communication modules and the Blynk app enabled data transmission and real-time monitoring of particulate matter, temperature, and humidity.

Acknowledgement

The authors would like to thank the Faculty of Electrical and Electronic Engineering, Universiti Tun Hussein Onn Malaysia for its support.

Conflict of Interest

Authors declare that there is no conflict of interests regarding the publication of the paper.

Author Contribution

The authors confirm contribution to the paper as follows: **study conception and design:** Nurul Syahidah Razak; **data collection:** Nurul Syahidah Razak; **analysis and interpretation of results:** Nurul Syahidah Razak; **draft manuscript preparation:** Nurul Syahidah Razak, Mariyam Jamilah Homam. All authors reviewed the results and approved the final version of the manuscript.

References

- [1] World Health Organization. (2018). Air quality guidelines: Global update 2018. World Health Organization. Retrieved from <https://www.who.int/publications/i/item/9789241550213>.
- [2] Smith, A. (2019). Air pollution and respiratory diseases. Medical Journal.
- [3] S. Kumar, "Advances in Sensor Technology," IEEE Transactions, 2022.
- [4] Nguyen, H., & Nguyen, T. (2021). Low-cost IoT based air quality monitoring system using Arduino. Proceedings of the International Conference on IoT and Smart Technology, 10(2), 123-130.
- [5] Sayed, M., & Hassan, Y. (2019). Design and implementation of an IoT based air quality monitoring system. Proceedings of the International Conference on Environmental Science and Technology, 5(1), 45-50.