

Smart Solar Powered Plant Irrigation Water Sprinkler Agriculture Robot

Kamelia Wahid, Mahyuzie Jenal*

¹ *Department of Electrical Engineering, Faculty of Electrical and Electronic Engineering, Universiti Tun Hussein Onn Malaysia, Parit Raja, 86400, MALAYSIA*

*Corresponding Author: mahyuzie@uthm.edu.my

DOI: <https://doi.org/10.30880/eeee.2025.06.02.048>

Article Info

Received: 27 June 2025

Accepted: 25 August 2025

Available online: 30 October 2025

Keywords

Solar Power Plant Irrigation, Sensor, Irrigation robot, Automated, Eco-friendly.

Abstract

This work intends to solve many problems like reducing wastage of water, harnessing natural energy and helping human do work more efficiently. As a result, it has taken the initiative to prevent water waste by developing a smart solar power plant irrigation water sprinkler plant. The project created an automated plant watering system and has distributed wireless network of sensor that are placed in mobile. An algorithm was developed with threshold values of sensor that was programmed into microcontroller-based gateway to control water quantity. Besides by integrating a solar panel provides a renewable energy source, reducing the reliance on external power supplies such as electricity or batteries. This makes the irrigation robot self-sustaining and capable of operating in remote or off-grid areas. As a result, the project is a success and able to provide sufficient water to the plants. Besides, water waste and energy consumption can be reduced since the project uses renewable energy so it is eco-friendly.

1. Introduction

Agriculture is an essential occupation that involves farming plants and taking care of animals for food, fiber, and other needed items, and it plays an important part in the survival of humans and society. It supplies most of the food consumed worldwide, guaranteeing people's sustenance and nutrition. In addition to producing food, agriculture provides jobs and livelihoods, which boosts economies, especially in rural areas where farming is the main source of income for many populations. However, depending on the activities involved, agriculture can also have an impact on a nation's biodiversity. Food grains, fibers, and raw materials are the three most important agricultural products [1]. Throughout human history, significant technological developments have been used to boost agricultural output while utilizing limited resources. However, rising population and climate change continue to threaten food supply and demand. Farmers spend almost 70% of their time monitoring and understanding crop condition rather than performing farm work. To support agricultural growth, we need precision and advanced technologies. To increase yields, farmers use site-specific methods known as precision farming. Besides improving crop production, they also employ various cropping strategies, such as growing different crops together or using intensive methods throughout the year. To meet these demands, modern technologies and service-based solutions will help produce more food. Integrating cutting-edge technologies is essential in the pursuit of sustainable agriculture in order to maximize productivity and reduce environmental impact [2]. An important development in contemporary farming methods is Solar-Powered Irrigation water Sprinkler Robot. This innovative system ensures appropriate water distribution while conserving resources by automating irrigation procedures using renewable solar energy [3].

Traditional irrigation systems typically require huge, expensive piping designs, which can be both costly and difficult to maintain. In order to transport water throughout agricultural fields, these systems rely on an extensive

system of pipelines and sprinklers, which may result in inefficiencies. For many farmers, particularly those in regions that are developing, the high cost of piping and the difficulty of installation pose significant challenges. Uneven water distribution can also be a result of conventional irrigation systems more likely for leaks and breakdowns. This can occasionally result in overflow in certain places, wasting precious water supplies while underirrigating other areas. The risk of leaks and inefficiencies wastes water, raises operational costs, and reduces crop yields, highlighting the need for more efficient, cost-effective, and dependable irrigation solutions.

2. Literature Review

2.1 Farming Innovation for Sustainable Living

Farming innovation involves using new technologies, techniques, and organizational structures to make agriculture more productive, efficient, and environmentally sustainable as shown in Fig 1. Key strategies include precision farming, regenerative practices, and vertical farming, along with modern tools like automation and IoT devices to monitor resources such as water and pest control. This allows for resource efficiency and reduces environmental impact. Solar-powered irrigation systems play a major role by using sunlight to generate electricity which power water pumps [4]. As climate change, water scarcity, and food security become pressing concerns. Some the new developments include the application like recycled wastewater, rainwater harvesting, and solar-powered sprinkler robots becoming important [5]. These technologies help reduce labor, save time, and improve efficiency. Overall, the evolution of irrigation reflects human creativity in addressing agricultural challenges and adapting to changing environmental needs.

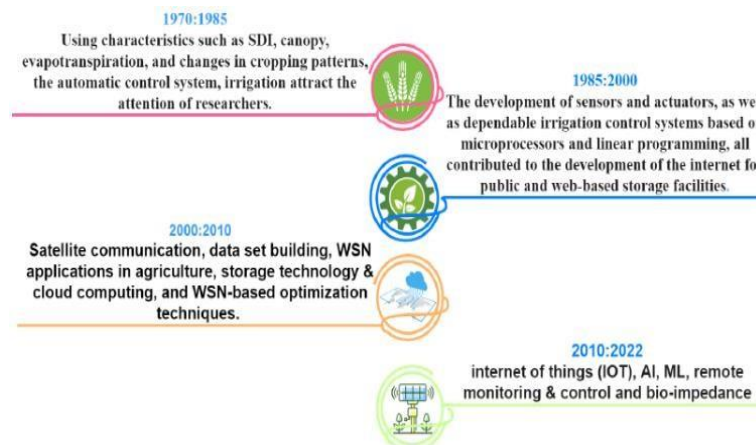

Fig. 1 The evolution of the irrigation system

2.2 Smart Irrigation Water Sprinkler Robot

The plant irrigation sprinkler robot system combines robotics, automation, and precision irrigation to efficiently water plants. It features a mobile robot with a built-in water tank and sprinkler that moves around the field, spraying water as it goes eliminating the need for complex piping systems [6]. By using real-time data, automation, and adjustable spraying mechanisms, the robot ensures water is delivered accurately and only where needed. Ultrasonic sensors help the robot navigate fields safely by detecting and avoiding obstacles. This system reduces water waste through targeted watering methods like drip and sprinkler systems, preventing runoff and conserving resources while improving crop yields. In addition to efficient water usage, the robot also offers IoT connectivity, allowing users to monitor and control the system remotely through mobile apps or web platforms. It can run on solar power, making it energy-efficient and environmentally friendly. The robot is suitable for use in small gardens, large farms, and public spaces due to its scalable and adaptable design. Optional features like nutrient mixing and programmable spraying patterns enhance its performance. Overall, this robot represents a modern, sustainable solution for smart irrigation, offering cost savings, increased efficiency, and reduced environmental impact.

2.3 Solar-Powered Irrigation Robot

In today's fast-paced world, many people struggle to find time or motivation for planting and maintaining greenery. To address this, a smart solar-powered irrigation robot offers an effective and sustainable solution. This advanced system automates plant watering using solar energy, making it ideal for those with limited time. Equipped with solar panels, rechargeable batteries, electric motors, and water storage, the robot can operate independently by harnessing sunlight and storing energy for use even on cloudy days [7]. The robot ensures

efficient and precise irrigation by delivering water directly to plant roots, reducing waste and improving overall water usage. Its accurate navigation system guarantees even distribution, preventing over or under-watering across the field. This not only enhances crop quality and yield but also minimizes manual labor, allowing farmers to focus on other important farming tasks. In summary, the solar-powered irrigation robot combines renewable energy with automation to promote sustainable agriculture and make plant care more accessible and efficient.

3. Methodology

This part explains and depicts the techniques and procedures used throughout the project's conception and development. The method's description should be more detailed before it is implemented. Therefore, this chapter will be used to review the project's block diagram, circuit design for the chassis robot and flowchart system of the project.

3.1 Design of the Project

Figure 2 shows the block diagram for the smart solar power irrigation water sprinkler agriculture robot project. It also illustrates the functionality and connectivity of the components that allow effective and smart farming. The ESP32 microcontroller is the system main component and holds responsibility for controlling the robot's automation. The system is powered by a solar power system. The solar panel is connected to a solar charger controller and it regulates the battery's charging process, preventing overcharging and damage. Other than that, some crucial components are used by the robot to sense and regulate its environment. When navigating fields, the robot avoids collisions by using an ultrasonic sensor to identify surrounding obstacles. A live video stream from an ESP32-Cam module is very helpful for remotely keeping an eye on the robot's environment. The Blynk platform, a mobile app interface that enables the user to remotely watch and control the robot in real time, transmits this stream together with sensor data. Blynk makes it highly responsive and user-friendly by enabling commands for turning on or off the water pump, manually controlling the robot, and monitoring visual and sensor guidance.

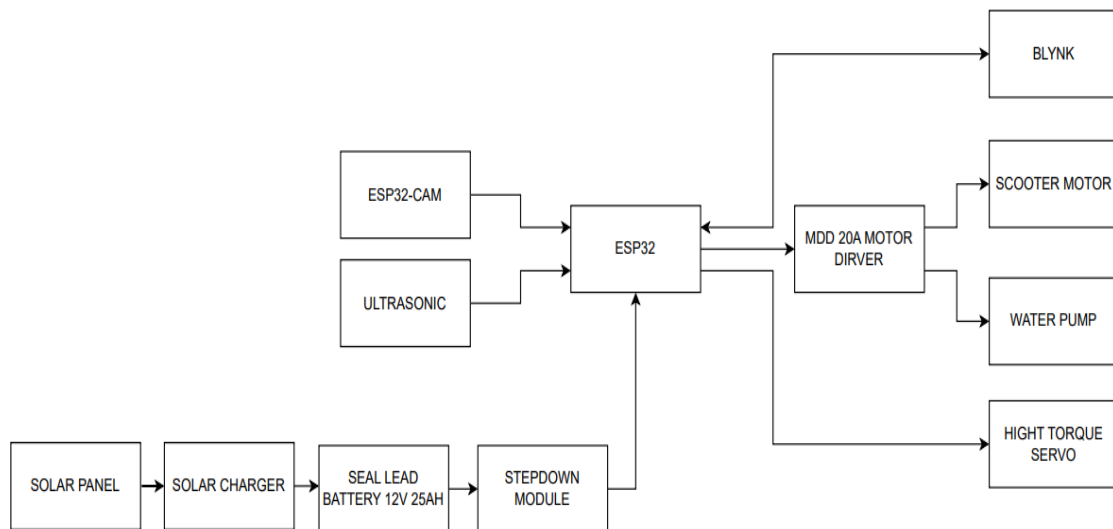

Fig. 2 Block diagram for the project

3.2 Circuit Design for the Chassis Robot

Figure 3 shows the circuit design shows a smart solar powered plant irrigation water sprinkler agriculture robot. Other than that, it has components such as sensors, ESP microcontroller, high pressure water pump and others. The connectivity of the components and the controller make it the system to automatically work for instance control the flow of energy.

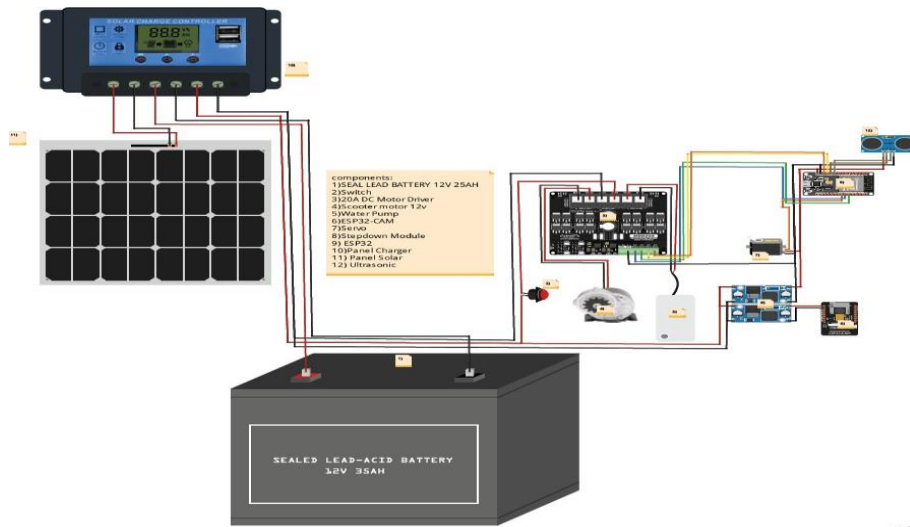

Fig. 3 Circuit Design for the Chassis Robot

3.3 Flowchart System of the Project

This flowchart begins with system initialization, where the ESP32 microcontroller boots up and connects to a Wi-Fi network. The ESP32 microcontroller powers up and establishes a connection with a Wi-Fi network during system initialization, which is where the flowchart starts. This step is important because it makes it possible to integrate the robot with the Blynk software, which allows smartphone operation of the robot remotely. It also develops a connection with important components during startup, such as the ultrasonic sensor, which aids in identifying any obstructions in the robot's route, and the ESP32-CAM, which offers a real-time video feed. Once started, the robot enters its main operating mode, where it uses the ESP32 to read sensor data and receive commands from the Blynk app. The water pump can be activated manually or automatically during ideal times like early morning or late afternoon to water plants efficiently. The robot moves forward using a 12V scooter motor controlled by a 20A DC motor driver, but only if no obstacles are detected by the ultrasonic sensor. Users can also control its direction forward, backward, left, or right via app buttons, allowing it to navigate around obstacles or tight spaces. All actions are based on real-time data, user input, and video feedback, making it a smart and reliable tool for modern precision farming

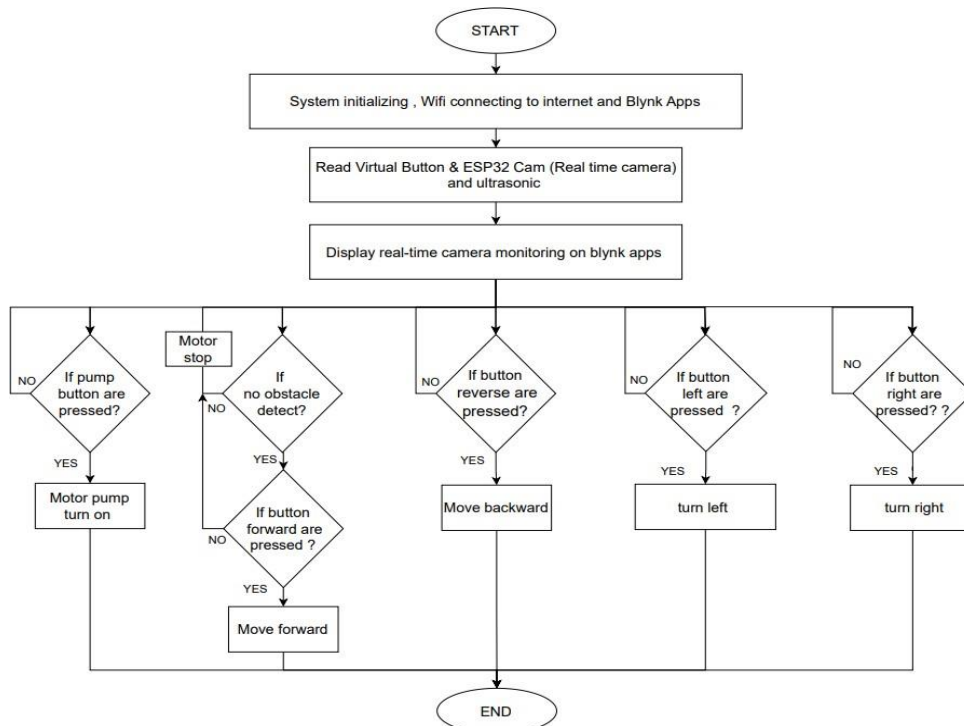

Fig. 4 Flowchart system of the project

4. Result and Analysis

The conclusions of this work and the results achieved in the performance analysis of smart solar powered plant irrigation water sprinkler agriculture robot. Key parameters such as voltage, current, power output obstacle detection accuracy were evaluated. Integration with the Blynk platform enabled real-time monitoring and alerts, enhancing system reliability and user convenience. Overall, the results demonstrate the system’s effectiveness in meeting the project objectives.

4.1 Electrical Parameters of PV System Without Loads for during sunny and cloudy day

This section shows the results and discussion the data testing of the solar panel without load for output values of horizontal axis and output values for 45° axis during sunny and cloudy day as shown in Figure 5.



Fig. 5 (a) Horizontal placement; (b) 45° tilted placement

Table 1 Comparison of Output Values of Solar Panel Without Load between Horizontal and 45° Axis Condition during sunny day.

	Horizontal Axis	45° Axis
Total Power (W)	415.44	473.59
Average Power (W)	46.16	52.62

Table 2 Comparison of Output Values of Solar Panel without Load between Horizontal and 45° Axis Condition during cloudy day.

	Horizontal Axis	45° Axis
Total Power (W)	319.29	377.49
Average Power (W)	35.48	44.59

Based on the data, the solar panel tilted at a 45° angle consistently produced higher power output than the horizontal setup in both sunny and cloudy conditions. On sunny days, the tilted panel generated 473.59 W with an average of 52.62 W, compared to the horizontal panel's 415.44 W and 46.16 W average. Even under cloudy skies, the tilted panel outperformed with 377.49 W total and a 44.59 W average, versus the horizontal setup’s 319.29 W and 35.48 W average. This highlights that a 45° tilt allows better alignment with the sun’s rays, improving efficiency even in less ideal weather.

4.2 Irradiance Test

Figure 6 shows the irradiance test analysis is conducted in order to measure the amount of solar energy received by the surface of the solar panel. It is typically expressed in watts per square meter (W/m²). This analysis is crucial because the performance of a PV system is directly influenced by the level of solar irradiance that is being received. Without sufficient irradiance, the solar panel cannot generate the necessary power to operate the connected system effectively. The test was conducted for three days to ensure more reliable data.

The graph clearly shows that difference in solar radiance between horizontal surface and a 45 tilted surface throughout the day. The trend lines indicate that the 45 tilt captures more sunlight, especially in the morning and afternoon which results in higher irradiance than horizontal surface.

4.3 System Operation by Blynk

The Blynk program allows for real-time monitoring of irrigation activities to improve efficiency, and the project incorporates the use of a smart solar-powered irrigation water spray robot. This method efficiently powers the

robot's irrigation mechanism by utilizing solar energy. By using the Blynk app on a smartphone, consumers can remotely operate the system, plan automated watering periods and keep an eye on environment of farming. The Blynk application user interface for mobile system monitoring in Table 3.

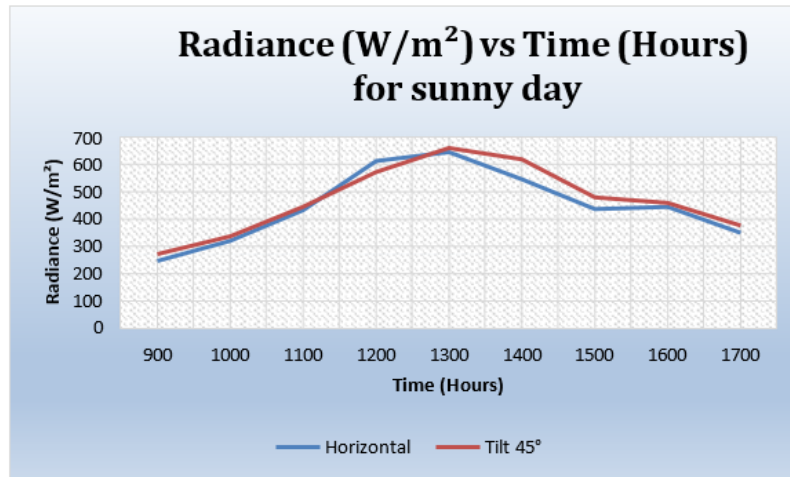

Fig. 6 The graph of Irradiance Test during sunny day

Table 3 The Blynk System

Application	Description
	<ul style="list-style-type: none"> • There are 4 keys in the remote for controlling the Irrigation Robot. This is interfaced to the controller. The operation of the keys is: <ul style="list-style-type: none"> • Forward • Reverse • Left turn • Right turn • There is distance value for monitor ultrasonic sensor and LED indicator to show there is object at in front.
	<ul style="list-style-type: none"> • The robot irrigation also shows the real time of image from ESP32-CAM.

5. Conclusion

In conclusion, the Smart Solar-Powered Irrigation Water Sprinkler Robot effectively combines renewable energy, automation, and modern technology to enhance agricultural practices. Powered by solar energy, the system operates sustainably and cost-efficiently, making it ideal for remote and off-grid farming. By integrating

sensors, a microcontroller, and wireless control, the robot provides precise irrigation, reduces water and energy waste, and supports real-time monitoring and decision-making. This innovative solution not only increases crop yields and minimizes manual labor but also promotes eco-friendly and adaptable farming methods, offering a scalable and practical approach to sustainable agriculture.

Acknowledgement

The authors would like to thank and express the deepest gratitude the Faculty of Electrical and Electronic Engineering, Universiti Tun Hussein Onn Malaysia for its support. Their guidance and assistance have been instrumental in the successful completion of this endeavor.

Conflict of Interest

Authors declare that there is no conflict of interests regarding the publication of the paper.

Author Contribution

Study conception and design: Nur Kamelia Binti Abdul Wahid, Mahyuzie Bin Jenal; **Data collection:** Nur Kamelia Binti Abdul Wahid; **Analysis and interpretation of results:** Nur Kamelia Binti Abdul Wahid, Mahyuzie Bin Jenal; **Draft manuscript preparation:** Nur Kamelia Binti Abdul Wahid, Mahyuzie Bin Jenal. All authors reviewed the results and approved the final version of the manuscript.

References

- [1] Rodriguez, M. a. B. (2024, April 24). Why is agriculture important? Benefits and its role Maryville Online. Maryville University [Online]. Available <https://online.maryville.edu/blog/why-is-agriculture-important/>
- [2] Khan, N., Ray, R. L., Sargani, G. R., Ihtisham, M., Khayyam, M., & Ismail, S. (2021). Current Progress and Future Prospects of Agriculture Technology: Gateway to Sustainable Agriculture. *Sustainability*, 13(9), 4883. [Online]. Available <https://doi.org/10.3390/su13094883>
- [3] You, L. X., Shariffudin, N., & Hasan, M. Z. (2021). Development of Solar Powered Sprinkler Robot Based on Watering Plant Using IOT Approach. *Journal of Physics Conference Series*, 2107(1), 012024. [Online]. Available <https://doi.org/10.1088/1742-6596/2107/1/012024>
- [4] Saif. (2024, October 9). Top 5 Innovations In Irrigation Technology You Should Know About. Jebsen & Jessen Technology Turf & Irrigation. [Online]. Available <https://turftech.jjsea.com/blog/top-5-innovations-in-agricultural-irrigation-technology>
- [5] DIG Corp | The History and Evolution of Irrigation Techniques. (n.d.). [Online]. Available <https://www.digcorp.com/the-history-and-evolution-of-irrigation-techniques/>
- [6] BC, U., S, P., & International Research Journal of Modernization in Engineering, Technology and Science. (2024). PLANT IRRIGATION WATER SPRINKLER ROBOT. *International Research Journal of Modernization in Engineering Technology and Science*, 06(solar power irrigation robot). [Online]. Available https://www.irjmets.com/uploadedfiles/paper//issue_5_may_2024/57750/final
- [7] Snsct, S. R. (2023, December 19). SOLAR POWERED SPRINKLER IRRIGATION ROBOT. [Online]. Available <https://www.linkedin.com/pulse/solar-powered-sprinkler-irrigation-robot-sarvesan-r-snsct-xzowc>.