

## IoT Based Smart Pet Cage

**Thineswari A/P Pulainthran<sup>1</sup>, Jais Lias<sup>1\*</sup>**

<sup>1</sup>Faculty of Electrical and Electronic Engineering,  
Universiti Tun Hussein Onn Malaysia, 86400 Parit Raja, Johor, MALAYSIA

\*Corresponding Author Designation

DOI: <https://doi.org/10.30880/eeee.2022.03.01.007>

Received 19 January 2022; Accepted 06 March 2022; Available online 30 June 2022

**Abstract:** In this modern era, there is a lot of technological improvement in pet cages. The world is moving rapidly toward automated or smart mechanisms. The manual operation of pet cages may not be efficient for the modern world. Pet ownership is a wonderful experience that everyone should enjoy at least once in their lives. Pets are, without a doubt, animals. A pet is a companion as well as a sentient being. True, caring for a pet and ensuring that they remain healthy is a difficult responsibility, but with the appropriate information, it may be made a little easier. The owners worry about their pet's food consumption and its safety. There is a high chance that the food will get spoiled if left outside for a long time. This cage can sense the difference in temperature in the surrounding. A temperature sensor is added to this project for to detect the changes in the surrounding temperature. If the sensor senses the level of the temperature exceeded more than required, a notification will be sent to the owner and the cage gate will be open so that the pet can go to a safer place. A weight sensor is added to this project for feeding purposes based on a required weight. The feeding system in this cage also can dispense food accordingly based on its weight automatically. A water level sensor is also added to feed water for the pet. If the water level goes below than required level the water will start pumping the water into the feeder bottle automatically. IoT system is built in this project to operate manually the cage which allows the owner to open/close the cage manually. The simple cage was successfully built to set up the device into it so that it would make the testing process easier for result purposes.

**Keywords:** Pet Cage, Temperature Sensor, Feeding System, Dispense Food, IoT

### 1. Introduction

Nowadays, we can see many pet owners are going to work and they are worried about their pets at the home alone. Some really care about their pet as willing to send them to a pet care center. The smart cage was set up automatically. It has been created to assist pet owners in being more comfortable and relaxed. Assist animals in maintaining a healthy lifestyle. This smart cage is made from automatic trash disposal, self-cleaning automatic feeder sewage employing object detection and CCTV surveillance, and so forth. Detecting objects is a difficult task in computer vision. To recognize moving objects in

---

\*Corresponding author: [jaisl@uthm.edu.my](mailto:jaisl@uthm.edu.my)

2022 UTHM Publisher. All rights reserved.

[publisher.uthm.edu.my/periodicals/index.php/eeee](http://publisher.uthm.edu.my/periodicals/index.php/eeee)

the backdrop, various techniques have been utilized, including temporal differencing, background removal, and optical flow [1].

To raise a healthy pet, each meal's pet feeding must be carefully studied. When pets are not fed on time, it directly impacts their health. It can lead to malnutrition as well as a variety of ailments and disorders. As an outcome, by managing the feeding operation using a mobile application, this proposed machine will provide a solution to the problem mentioned earlier. It can feed a pet on time by scheduling it, setting the food quantity, and altering the food amount if the pet hasn't eaten its last meal. Finally, the system can figure out how much food should be provided each day. To calculate the amount of food to feed a pet per day, basic information such as the breed and weight of the pet can be filled in. Because the equipment is IoT-based, it can be used to track the amount of food fed to the pet at each meal to limit the risk of illness [2]. A new embedded development board and a new Wi-Fi development board are used in this design. The feeder now has more exact control of food and water delivery according to testing, and it employs IoT technology for remote control. You can use a remote camera to monitor the pet's behavior in real-time, and you can use your phone to monitor the feeding situation in real-time [3]. Therefore, this project aims to design and build an IoT-based smart pet cage with a safety feature that can open the gate when the temperature reaches a high temperature. Then, the system can measure and record data collection of temperature reading and the servo count of food dispensers and finally, the IoT system was implemented in the prototype.

A smart pet feeding machine that allows pets and their owners to share images of their pets' daily routines on Facebook. Pets can transmit a photo by pressing the NuriPet machine's pedal. Additionally, when pet owners use the NuriPet application to control the machine remotely, the machine feeds pet automatically. A pet feeder is made and built using a 3D printer to implement the device [4]. Smart cage is made up of six different parts. These modules include an automatic faces cleaner, a food provider, a comfortable environment temperature and light management, and a health monitor that are used to monitor and care for dogs when their owners are not there. A dependable safety agent is built to monitor the irregular current of the conveyance and analysis the dog's movement to secure the dog's safety in the smart cage [5]. The CC3200 makes use of the Yocto Project Linux kernel's compilation function, which allows it to automate pet feeding and watering, as well as perform regular and quantitative feeding procedures. The feeder now has more exact control of food and water delivery according to testing, and it employs IoT technology for remote control. You can use a remote camera to monitor the pet's behaviour in real-time, and you can use your phone to monitor the feeding situation in real-time [6,7].

## 2. Materials and Methods

### 2.1 IoT Based Smart Pet Cage Block Diagram

The input of this project are temperature and humidity sensor (DHT22), weighing sensor (HX711) and water level sensor, the control unit is ESP32(WIFI module) and the output are servo motor, water pump and LCD module. Figure 1 shows the block diagram of this project.

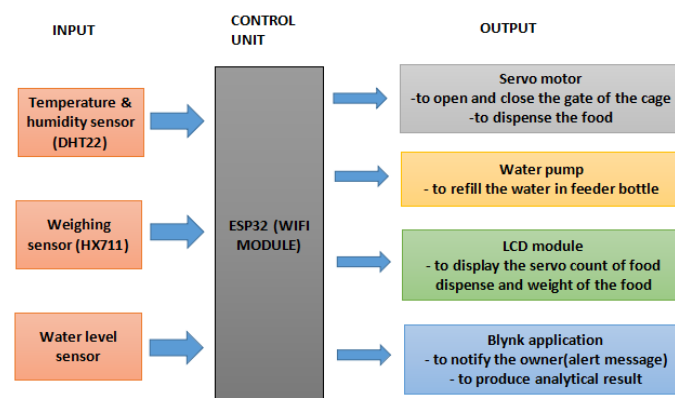

Figure 1: Block diagram of IoT base smart pet cage

## 2.2 Methods

Figures 2 and 3 show the process flowchart for automatic mode. All the process shows incorrect order accordingly. The purpose of this flow chart is to give an overview of the steps for this project automatically.

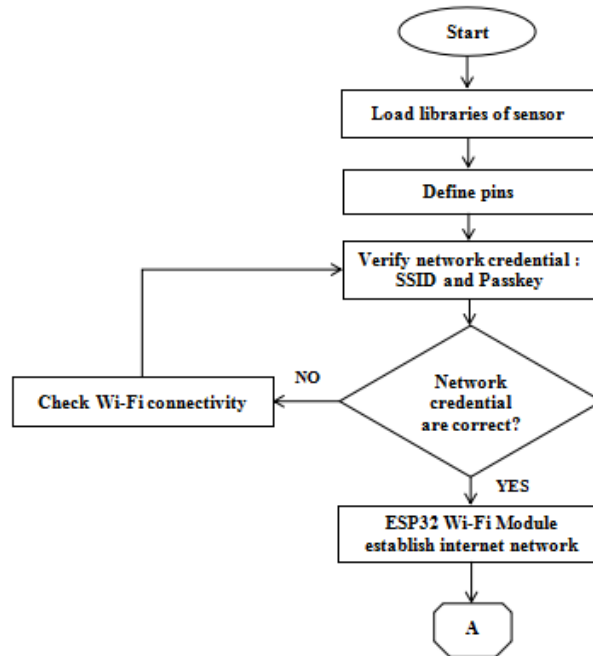

Figure 2: Process flowchart (automatic mode)

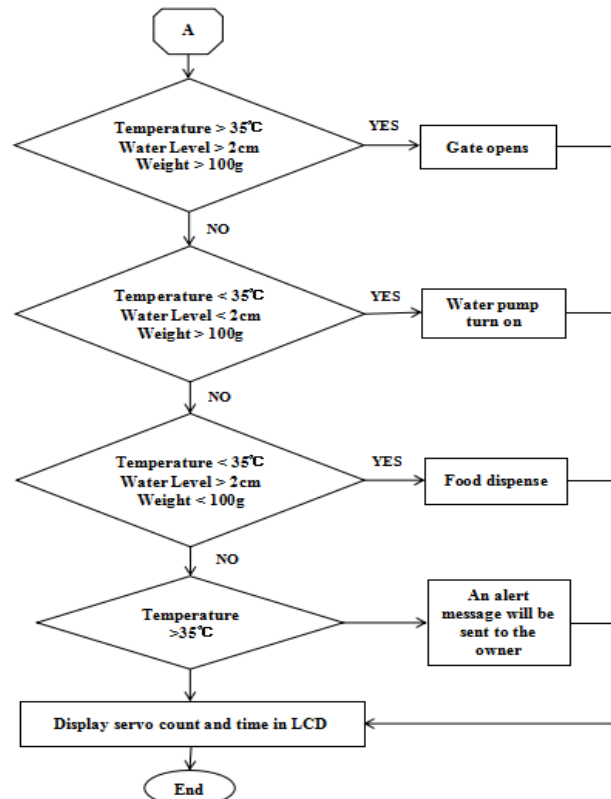

Figure 3: Process flowchart (automatic mode)

Figure 4 shows the process flowchart for manual mode. The manual process of the pet cage is shown step by step accordingly. This manual mode function is to help the user to utilize if the automatic mode is failed or for any other maintenance purpose. The purpose of this flowchart is to give an overview of the steps of this project manually.

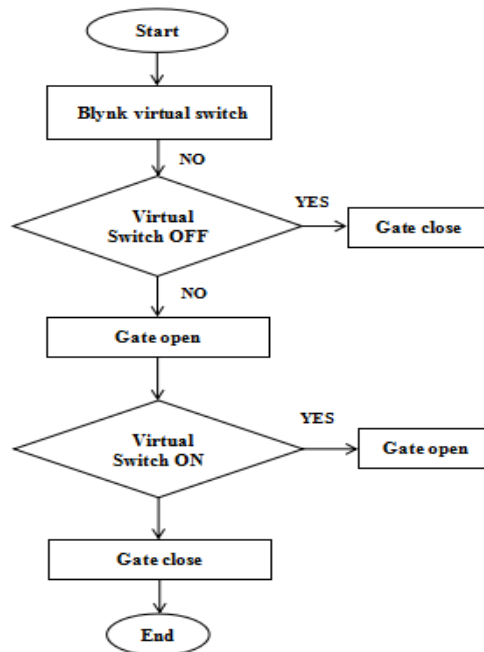

Figure 4: Process flowchart (manual mode)

### 2.3 Electronic Setup

All the sensors' connections are combined in this circuit diagram. Figure 5 shows the schematic diagram of this project.

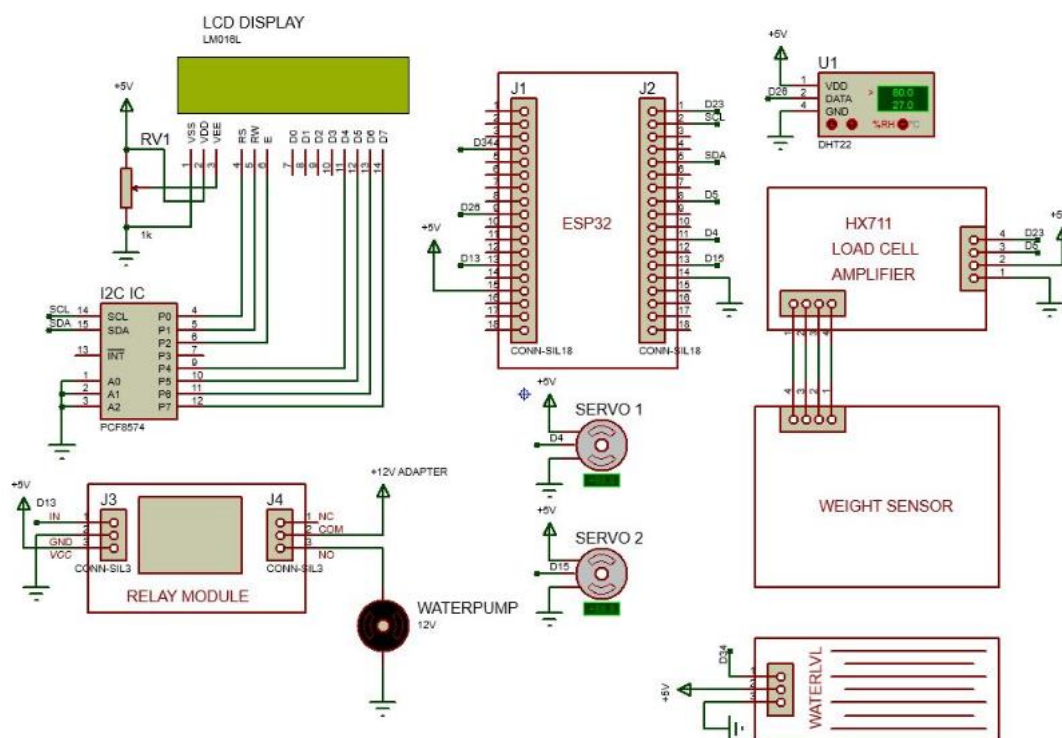

Figure 5: Schematic diagram of IoT based smart pet cage

### 3. Results and Discussion

#### 3.1 Prototype Setup

The outputs of this project are dispensed food by detecting the amount of food in the food tray using the weight sensor (HX711), filling up the feeder bottle by detecting low-level water using water level sensor from mini electronic water pump and opening the gate of the cage if the temperature sensor (DHT22) detects a high temperature. The data, which is obtained by a temperature sensor, DHT22 can be displayed through the Blynk application on a mobile phone. Then, the crucial part in the making of IoT based smart pet cage is where it is going to be placed for conducting the testing and obtaining some data. So, all the sensors were placed on a cage as a prototype, and it was ready to test and record data. The prototype of pet cage is shown in Figure 6.



**Figure 6: Prototype of pet cage**

Three testing conditions were carried out throughout this project, which is: a) gate opens when the temperature reaches above 35 degrees, b) food dispenses when weights below 100 grams and c) water refill when reaches below a certain level

#### 3.2 Experiment 1: The gate opens when the temperature reaches above 35 degree

In this experiment, a hairdryer is used to raise the temperature. DHT 22 work instantly right after the system connected to the internet and showed the surrounding temperature reading on Blynk application. The gate of the cage will be open automatically if the temperature is 35°C and above which allows the pet to get out of the cage if the house on fire. Figure 7 shows the gate opens when the temperature reaches above 35°C.



**Figure 7: Gate of the cage open due to high temperature**

### 3.3 Experiment 2: Food dispense when weights below 100 grams

In this experiment, the servo motor has been tested together with weighing sensor HX711 to dispense food. The servo motor and weighing sensor (HX711) work instantly, right after the system is connected to the internet and displays the weight on the weighing sensor. The servo motor will rotate 90° automatically if the weight on the weighing sensor is below 100gram so that the food can dispense food automatically for the pet inside the cage. The amount of food dispensed per rotation is 40 to 50 grams. Figure 8 shows the arrangement of food dispense in the cage.



**Figure 8 Arrangement of food dispenser**

### 3.4 Experiment 3: Water refill when reaches below a certain level

In this experiment, the water level sensor is tested with a mini electric water pump to fill up the water in the feeder bottle. The water level sensor and mini electric pump work instantly right after the system is connected to the internet. The mini electric pump will automatically start pumping the water outside to the bottle feeder when the water level is below 2 cm. Figure 9 shows the arrangement of the water level sensor and the mini electric pump in the cage.



**Figure 9: Arrangement of water level sensor and mini electric water pump**

### 3.5 Blynk System

The profile for IoT Based Smart Pet Cage was created in the Blynk application using a mobile phone. The application is available to be downloaded from any application store on a mobile phone. Figure 10 shows the completed Blynk profile for this project. This profile is named IoT Based Smart Pet Cage. There is one gauge meter which is for temperature reading and one button for controlling the gate of the cage manually. A line and bar chart were added for monitoring purposes [4]. A notification is also built into this app so that users can get notified when the surrounding temperature exceeds a normal temperature, and the gate is opened. Figure 10 shows the complete Blynk profile of this project.



**Figure 10: (a) Blynk profile of this project, (b) Notification that gate of the pet cage is open due to high temperature**

Figure 11 shows the line chart of temperature readings and the bar chart shows the gate is open and close in real-time. This line chart visualizes the reading result as soon as the system was online. It took a few moments for the fan to be taken action.

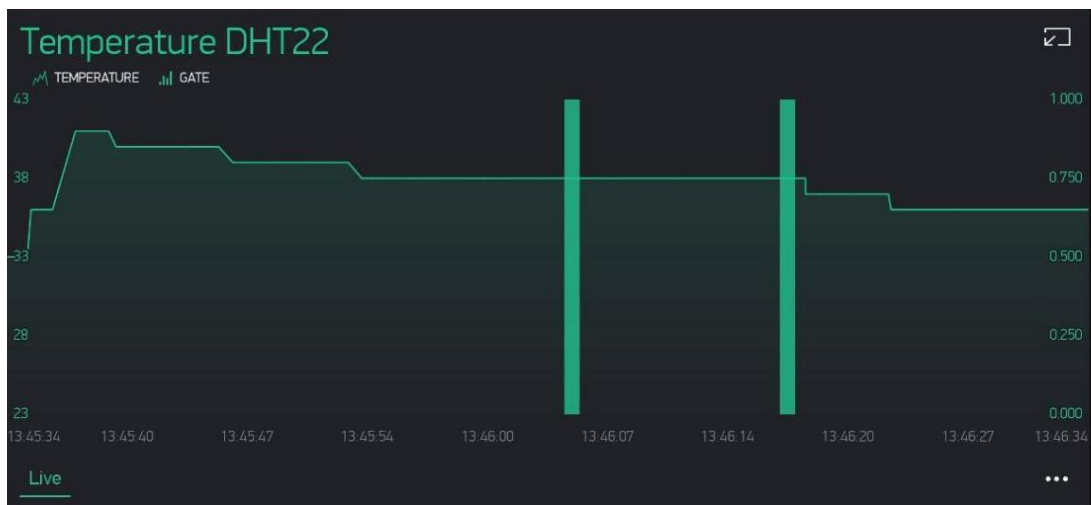

**Figure 11: The line chart of temperature readings and the bar chart shows the gate is open and close in real-time**

### 3.6 Data of Servo Count

From Figure 12, we are able to know the amount a puppy consumes food every day and get an average number. As per research, a normal healthy puppy (6months) eats 300gram to 400gram. We know that each rotation dispenses 40 grams of food from the dispenser.

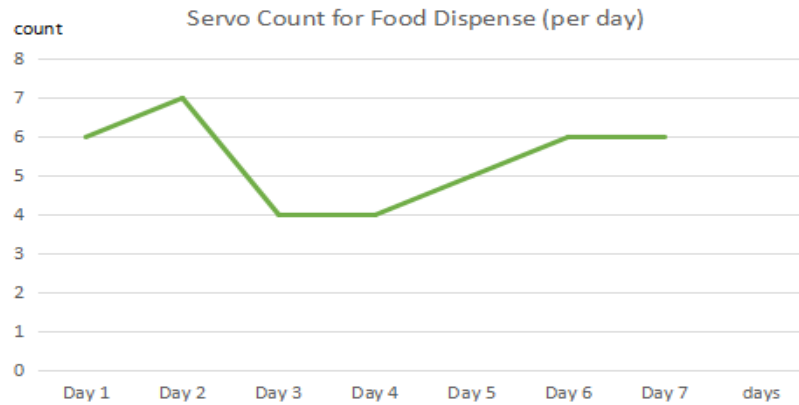

**Figure 12: Data of servo count**

### 3.7 Data of Temperature

This data can acknowledge the owner of the surrounding temperature daily. Figure 13 shows the average temperature reading for one week that has been summarized.

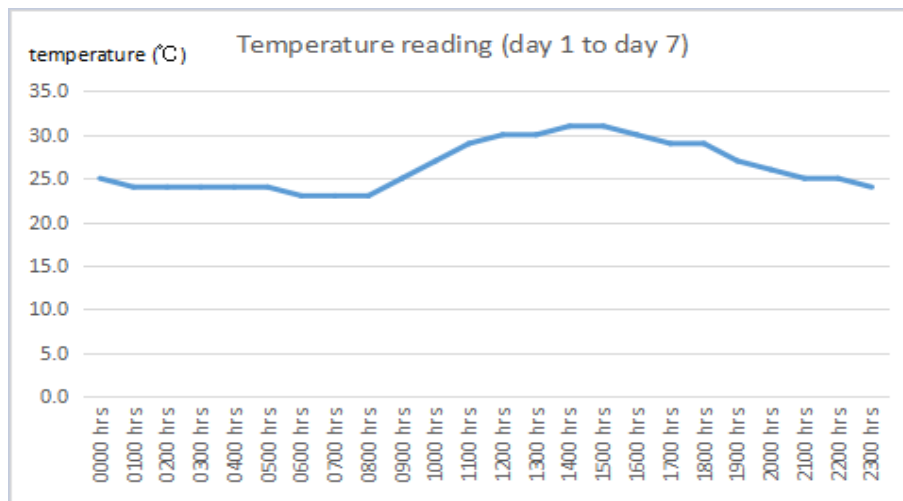

**Figure 13: The average temperature reading for one week that has been summarized**

## 4. Conclusion

In conclusion, an IoT-based smart pet cage is well designed, easy and affordable for pet owners. This project is IoT-based which can dispense the food and refill the water automatically and opens the gate when it detects a high temperature. The first objective has been achieved as a prototype design successfully. Next, the second objective is to dispense food by detecting less weight using a weight sensor and opening the gate when detecting a high temperature. Lastly, the objective of optimizing IoT implementation for the prototype through this project has been successful. The simple cage was successfully built to set up the device into it so that it would make the testing process easier for result purposes. This electronic system was successfully integrated with both hardware and software, which satisfied the objective of this project.



## **Acknowledgement**

The authors would like to thank the Faculty of Electrical and Electronic Engineering, Universiti Tun Hussein Onn Malaysia for its support.

## **References**

- [1] P. Suksaengjun, D. Thanapatay, J. Chinrungrueng and S. Nobuhiko, "Smart cage using object detection," 2015, pp. 1-5.
- [2] M Ibrahim, H Zakaria and EE Wei Xian, "Pet food autofeeder by using Arduino, " 2019, pp. 012-069.
- [3] B. Ma and N. Guo, "Design of Remote Pet Feeding System Based on ARM," 2020, pp. 1702-1704.
- [4] J. Jung, C. Ji, J. Sohn, H. Meng and B. Hwang, "NuriPet: A smart pet feeding machine for SNS," 2016, pp. 117-118.
- [5] K. S. Ng, P. Chen and P. Ting, "Smart Cage Implementation with Dependable Safety Agent for Dogs," 2017, pp. 231-232.
- [6] B. Ma and N. Guo, "Design of Remote Pet Feeding System Based on ARM," 2020, pp. 1702-1704.
- [7] Navindran A/L Alagari, & Lias, J, "IoT Based Smart Exhaust Fan," 2021, pp. 47-56.