

Perpetual Motion Generator Prototype

**Raja Iskandar Zulkarnain, Ahmad Zainuddin Azmi, Muhammad Syahmi
Danial Khairul Anwar, Khairulnizam Othman***

*Department of Mechanical Engineering, Centre for Diploma Studies, Universiti Tun Hussein Onn Malaysia, Pagoh
Higher Education Hub, 84600 Pagoh, Johor, MALAYSIA*

*Corresponding Author: nizam@uthm.edu.my

DOI: <https://doi.org/10.30880/mari.2024.05.03.023>

Article Info

Received: 01 March 2024

Accepted: 31 July 2024

Available online: 31 December 2024

Keywords

Conventional Energy Sources,
Environmental Impact, Off-Grid
Farming, Energy Generation,
Perpetual Motion Generator,
Capacitor Application

Abstract

The use of conventional energy sources, such as fossil fuels, has had a negative impact on the environment. Additionally, their limited availability is a growing concern as their consumption continues to rise. Farmers in Ayer Hitam face challenges in protecting their crops and repelling pests, with current methods being costly and generating inadequate income. These farmers also lack access to reliable energy sources, relying instead on expensive fuel-powered generators. This study focuses on the rotating wheel rim and holder project, aiming to analyze its performance in generating energy for a light bulb. The results and discussion section will provide a comprehensive analysis, quantifying the amount of energy produced and discussing the system's efficiency, limitations, challenges, and potential improvements. The design's practicality and sustainability, particularly for off-grid farming, will be emphasized. The prototype experiment compared the average speed of the rotating wheel with the theoretical value, highlighting the design's capabilities. The perpetual motion generator prototype proved successful in providing a continuous energy supply for the light bulb. Success factors included minimizing air resistance, reducing friction between components, and precise calibration of the magnet source. To enhance power output, the integration of an auxiliary capacitor circuit is necessary. This circuit acts as an energy storage unit, accumulating surplus power during peak performance and discharging it when power demand exceeds the generator's capacity. This approach ensures a stable and continuous power supply, making the generator suitable for applications requiring higher wattage levels. In conclusion, this study provides valuable insights into the feasibility and challenges associated with perpetual motion generators. While acknowledging skepticism within the scientific community, this achievement encourages further exploration and inspires researchers to push the boundaries of energy generation.

1. Introduction

Overall, the use of conventional energy sources such as fossil fuel is concerning as its continuous usage has affected the environment negatively. Not only that, but these energy sources are also finite and estimated to be exhausted quickly as the rate of usage is insanely high and is increasing day by day due to the current technological system which highly relies on these energy sources.

On the other hand, guarding crops and repelling pests are a few of the crucial parts in a farmer's career. This issue is immensely a huge problem when the options and currently viable methods are costing these farmers much more compared to their income. This issue is faced daily by the farmers in Ayer Hitam which have been affecting their crops which resulting in less profits at the end of their operation. Manually guarding crops is a tiring daily routine to maintain crop's health and quality but impossible to conduct when the circumstances are out of their capabilities. This is since the workers and farmers need to sleep during the mid-morning period which has left their crops vulnerable to the nocturnal pests that attack their crops and damage them. Plus, these farmers live in off grid regions which means that energy sources are not as viable and are limited compared to the regions in the city. This also limits their options to only being able to use the conventional generator available in the market to supply energy for the light source continuously for 8 to 11 hours. However, using it for pest trapping is not significant due to its noisy operation and carbon dioxide release [1]. This method is the only viable option for them to repel pests from their crops by attracting them to the light source. However, providing fuel for the generator would be costly for them, especially for maintaining its function to supply energy for extended periods to deter pests from the crops [2][3].

To solve said matter, prototype of a generator that is powered by infinite energy sources which can supply enough energy for a light source for a few hours continuously will be highly effective to guard the crops. Not only that, but this would also solve the exhausting energy sources issue which benefits the earth's health and sustainability. Unfortunately, the idea is still unproven even with countless studies conducted as its nature defies the law of thermodynamics which is the base of knowledge in understanding today's science foundation.

2. Literature Review

To design an optimum model for the perpetual motion generator prototype, there are several measures to be counted first. This includes understanding of the perpetual motion concept, design structure and the suitable material selection for each part of the component of the model. Finally, the designed perpetual motion generator will be analyzed of its performance and other parameters involved in its operation to produce sufficient energy to supply electricity for the light source.

2.1 Perpetual Motion Concept

The perpetual motion concept is an enthusiastic topic for certain people such as past scientists and inventors. Therefore, many of them conducted studies and designed their own imaginative designs to operate in such a way to produce energy while being independent from relying on any external sources in its system. From past research, there are two concepts of perpetual motion that were commonly tested for this topic. Those are gravitational energy based perpetual motion and magnetic attraction based perpetual motion [4][5][6][7]. Each concept shares the same result in their idea yet with different power sources to initiate and continuously create motions into kinetic energy which would then be converted into applicable energy to power other machines prior to their connected energy converter. Nonetheless of their methods, both ideas aim to create motion in an unperturbed system to create kinetic energy perpetually.

2.2 Design structure and working mechanisms

For this project, the prototype model for the perpetual motion generator will be a wheel and a stand in general. The design chosen is a direct reference from the past proposed design by F.S Mackintosh. This design comprises of a wheel as the rotor with the stand as its stator. Below the wheel will be installed with a magnet to create attraction towards a metallic ball in-between the wheel which will cause it to rotate as well in the opposed direction from the spinning ball [8]. The wheel would be connected to its energy converter device, a dynamo, which is also interconnected with the light source where it would supply the converted electrical energy to. This design has been translated into a 3D drawing through SolidWorks' software.

2.3 Material Selection

The model was decided to be developed based on the magnetic attraction perpetual motion concept. Regarding that, past studies showed that researchers tend to use a specific material of magnet in their perpetual motion design. This magnet is made of neodymium as it is claimed to have the strongest magnetic attraction compared to other materials. As for the stand, aluminum is chosen to ensure the toughness of the stand. On the other hand, the wheel as the rotor will be made of plastic to prevent it from being attracted to the power source, magnet, since magnets attracts metal in general and that would jeopardize the whole working mechanism since the wheel is supposedly to rotate in cause of the spinning ball, not from the attraction of the magnet which will make it to stay in its position.

3. Equations

Describing a perpetual wheel involving a permanent magnet and ball bearing requires acknowledging that perpetual motion machines, which aim to operate indefinitely without an energy source, are implausible due to the conservation of energy. However, if discussing a wheel designed for prolonged motion due to magnetic or other forces, understanding the involved physics becomes pertinent [8].

To model the wheel's motion with a permanent magnet and ball bearing, one would typically consider forces like gravity, magnetic forces, and friction. This equation accounts for the forces influencing the motion. The gravity force depends on the wheel's mass and the acceleration due to gravity, while the magnetic force relies on the magnet's strength and distance. The frictional force hinges on the surface nature and wheel construction.

It's crucial to recognize that the real-world behavior of such a system can be intricate, possibly involving differential equations. Furthermore, perpetual motion remains unattainable due to the fundamental principles of thermodynamics. Any perpetual motion device would violate these principles. If you have specific details or equations in mind, please provide more information for more tailored assistance.

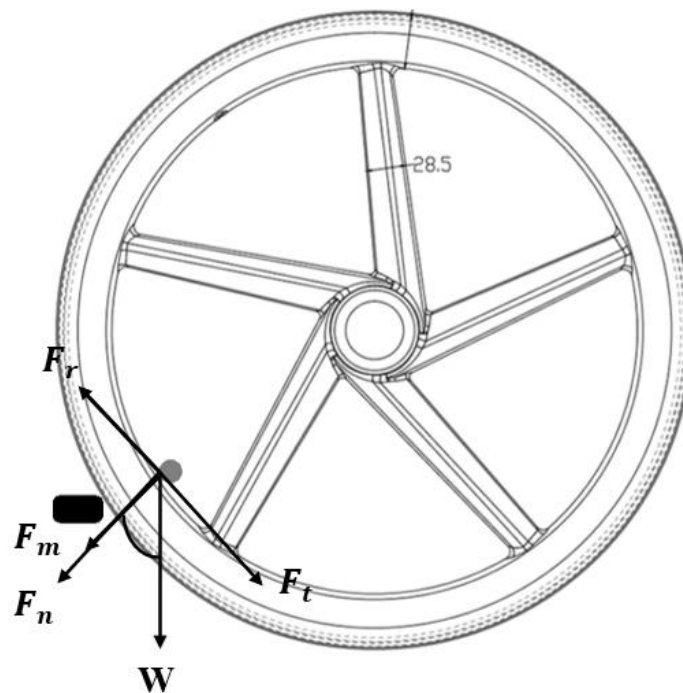

Fig. 1 This showcases display formation and Movement of the Perpetual Wheel Mechanism

To calculate the force exerted by a Neodymium magnet on a 2.02 grams ball bearing, we need to consider the gravitational force, magnetic force, and any frictional force. Let's denote:

- m as the mass of the ball bearing,
- g as the acceleration due to gravity (approximately 9.81 m/s^2),
- d as the distance between the magnet and the ball bearing,
- B as the magnetic field strength of the Neodymium magnet,
- F_r as the frictional force,
- W as the gravitational force,
- F_m as the magnetic force.

The force exerted by gravity is given by $W = mg = (0.00202) (9.81) = 0.0198162 \text{ N}$. The magnetic force can be calculated using the formula $F_m = BI$, where I is the current induced due to the motion of the ball bearing through the magnetic field as in Fig. 1.

Now, the total force required to move the wheel is the sum of these forces, the friction coefficient (μ) for ABS plastic ($\mu = 0.35$) and the magnetic field strength ($B = 1.48 \text{ T}$), we can proceed with calculating the force components. Next, the magnetic force (F_m) is given by $F_m = BI$. However, the current (I) induced due to the motion through the magnetic field is usually a complex factor and might depend on the specific details of your setup. Without information regarding the velocity or any induced current, certain assumptions may be necessary.

This equation delineates the forces impacting the motion. The gravitational force is contingent on the mass of the wheel and the acceleration due to gravity, whereas the magnetic force is contingent on the strength of the

magnet and the separation distance. The frictional force is contingent on the nature of the surface and the construction of the wheel. Derived from a rotating wheel and weight experiment, the wheel begins to move with a weight of 1.23 grams, corresponding to an accumulated force of approximately 0.0120663 Newtons, considered as the minimal frictional force required for the wheel's motion. Simultaneously, the magnetic force (F_m) is estimated at around 5 Newtons, responsible for maintaining the bearing in place to slide and roll between the wheel and the magnet, with a pulling distance of 12.5 mm, determined from measurement results obtained from the N52 Neodymium Magnet, as illustrated in the graph in Fig. 2.

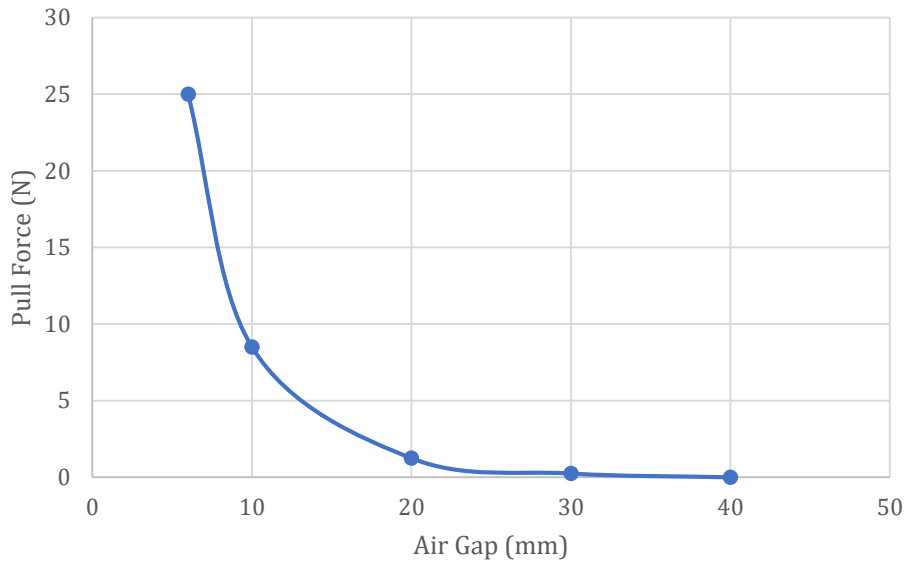

Fig. 2 Magnetic Pull Force Measurement Records for N52 Neodymium Magnet

Expressing the frictional force as $F_r = \mu F_N$, where μ is the coefficient of friction and F_N is the normal force, this force must surpass the accumulated force of approximately 0.0120663 N for the wheel to initiate motion

$$\begin{aligned}
 F_N &= w \cos 45^\circ + F_m \\
 F_N &= 0.01071 + 5
 \end{aligned}
 \tag{1}$$

$$\begin{aligned}
 F_r &= \mu F_N - mg(\sin 45^\circ) \\
 F_r &= (0.35)(5.01071) - 0.0198162(\sin 45^\circ) = 1.7368 \text{ N}
 \end{aligned}
 \tag{2}$$

By calculating this sum, we determine the friction force needed to set the perpetual wheel in motion. This force, exceeding the minimal requirement, contributes to the overall force necessary for wheel movement, accounting for factors such as vibration loss and bearing tilt under the specified conditions.

4. Material and Methodology

In the design of the rotating design rim and holder, careful consideration was given to material selection and the methodology employed. The rim was crafted from lightweight yet durable aluminium alloy, striking a balance between strength and weight efficiency. This material choice ensures that the rim can withstand the stresses of cycling while keeping the overall weight of the wheel manageable.

The methodology encompassed precision machining and welding techniques to create the rim and holder. Advanced SolidWorks software was utilized for the initial design, allowing for precise measurements and geometric configurations. CNC machining processes were employed to shape and refine the rim, ensuring its structural integrity. For the holder, welding techniques were meticulously executed to provide a secure attachment point for the rim. The combination of high-quality materials and a meticulous manufacturing methodology ensures that the rotating rim and holder meet the desired standards for performance, safety, and reliability.

In the development of the rotating rim and holder, meticulous attention was dedicated to material selection and the applied methodology. The rim, crucial to both strength and weight efficiency, was meticulously crafted from a lightweight yet robust aluminum alloy. This choice ensures the rim's resilience under cycling stresses while maintaining an overall manageable weight. Precision machining and welding techniques were incorporated into the methodology, with the initial design facilitated by advanced SolidWorks software for accurate measurements and geometric configurations. CNC machining refined the rim, ensuring structural integrity, while welding

techniques secured the holder. This harmonious blend of high-quality materials and precise manufacturing guarantees that the rotating rim and holder meet stringent standards for performance, safety, and reliability.

Wheel balancing is a crucial aspect of vehicle safety and performance. In SolidWorks, it simulate and analyse wheel balancing to ensure even weight distribution, reducing vibrations and enhancing perpetual motion generator stability [9]. By modelling the wheel and tire assembly, you can examine the impact of weight imbalances and make necessary adjustments. SolidWorks offers tools for precise measurements, allowing us to identify heavy spots and optimize weight distribution. It also experiments with different counterweights or redistributing weights within the wheel to achieve better balance. This virtual testing in SolidWorks helps engineers and designers fine-tune perpetual motion generator before physical prototyping, ultimately leading to safer and more efficient.

In Fig. 3, the meticulously designed and analyzed 5-spoke cycle bike rim is presented. Utilizing SolidWorks, the system underwent a detailed modeling process, prioritizing both aesthetic appeal and structural integrity. The analysis involved evaluating stress points, ensuring the rim's resilience under various conditions. Precision in SolidWorks allowed for optimal measurements and geometric configurations. The result is a well-balanced, rotating rim that seamlessly blends design finesse with structural robustness for a superior rotating application.

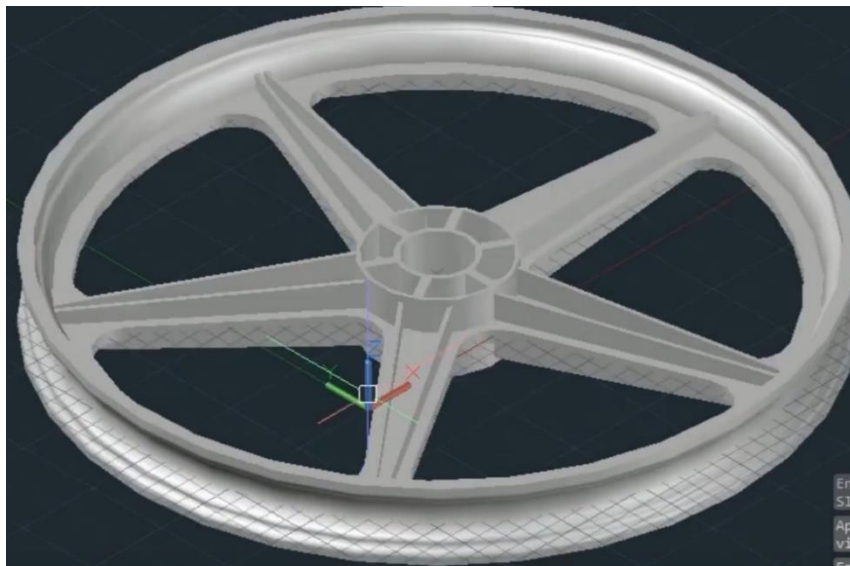

Fig. 3 Analysis for balanced 5-spoke cycle bike rim

4.1 Materials

Table 1 Store-bought items

Item	Function
Wheel	Act as the wheel
Dynamo attached with light bulb	Act as the light source
Steel bearing ball	To initiate the motion
Magnet	To attract the steel bearing ball for it to create motion as it spins

In this section, we present the detailed inventory of materials employed in our project, categorized into two tables for clarity and comprehensive documentation. Table 1 includes a catalog of store-bought materials, outlining the various components and parts sourced from suppliers. These items, readily available in the market, formed a crucial part of our project's construction.

Table 2 Items taken from the workshop

Item	Function
Metal pieces	To construct the wheel stand

Table 2, on the other hand, provides an inventory of materials obtained from our workshop or fabricated in-house. These materials reflect our project's reliance on customized components and the skilled craftsmanship of

our team. The items listed in this table showcase the innovation and technical expertise involved in creating specific parts tailored to the project's unique requirements.

The dichotomy between these two tables underlines the blend of off-the-shelf components for practicality and the bespoke elements crafted to meet the project's precise specifications. Together, these materials played a pivotal role in the realization of our project, ensuring both efficiency and functionality in its final design.

The design and methodology for the rotating rim and holder involved the incorporation of various critical components sourced from the workshop. The wheel was primarily used to serve as the central wheel, ensuring its proper functioning in the overall setup. A dynamo, coupled with a light bulb, was integrated to act as the primary light source, a crucial element for this system. To initiate motion, steel bearing balls were employed, interacting with magnets that attracted them and set the motion in progress.

In terms of structural components, metal pieces were obtained and employed to construct the wheel's stand, providing the necessary support and stability. These elements were essential in creating a robust and efficient system for generating energy and illuminating the attached light bulb, which served as a critical aspect of the overall design and functionality of the rotating wheel rim and holder.

4.2 Methodology

The production process of the prototype was done in two phases. First is the construction of the wheel stand. This includes the cutting of metal pieces in desired dimension and attaching them together by welding process. The whole process took about 4 weeks since they failed products and repetition were required to redo the whole process.

Next is wheel production. The process was short as it only required the splitting of the wheel and the grinding and sanding of the surface to make it smooth and even before joining them invertedly with a gap between them. Regardless, the process took about 2 weeks as the first wheel was missing from its pair and needed to buy another one through online shopping and redo the whole process again.

Finally, in the assembly phase, the wheel and its stand are joined together using a bearing and rod. Subsequently, the dynamo and light bulb are installed on the stand. The assembly process is relatively quick since it doesn't necessitate external tools, only screws and adjustments to connect the components. The completed assembly can be viewed in Fig. 4 below.



Fig. 4 *Finished product of prototype*

5. Results and Discussion

The results and discussion section of the design for the rotating wheel rim and holder project is expected to provide a comprehensive analysis of the system's performance and its implications. It should present the empirical outcomes and insights gained from the experiment. This section aims to confirm whether the designed system successfully generates energy to illuminate the light bulb, and if so, to what extent. It should quantify the amount of energy produced, possibly in terms of voltage, current, or lumens of light, and compare it with the expected values.

Furthermore, the discussion should delve into the efficiency of the system, addressing any challenges encountered during the design process. It should analyze how well the components, such as the dynamo, wheel,

and steel bearing balls, functioned in tandem. Any limitations or constraints related to the design and materials should be acknowledged and discussed. Additionally, this section should consider potential improvements and optimizations for the system, reflecting on the lessons learned and suggesting avenues for future work. It should emphasize the practicality and sustainability of the design, especially concerning its application in off-grid farming. Overall, the results and discussion should provide valuable insights into the performance, limitations, and potential of the rotating wheel rim and holder.

5.1 Prototype Experiment

For this section, our design is tested based on the wheel's speed in rotating. It was done several times to calculate the average speed acquired experimentally and compared it to the theoretical value. The test conducted was recorded of its data which are tabulated. The test includes the revolution of the wheel capable of in 10 seconds for 3 trials. Then the revolution is multiplied by 6 for 10 seconds multiplied by 6 = 60 seconds which also equates to 1 minute to obtain the revolution per minute (rpm) value. And only then it can be compared to the theoretical value to analyze its capabilities.

5.2 Results

Table 3 *Material list*

Trial	Revolution in 10 seconds	Revolution per minute, rpm
1	3.7	22.8
2	3.8	22.8
3	4.3	25.8
4	3.8	22.8
5	3.9	23.4

Table 3 displays the results of the test. According to the findings, the project can generate sufficient energy to power the light source, as the average recorded wheel speed stands at 26.33 revolutions per minute (rpm). Therefore, it meets the minimum speed requirement for sustaining the light bulb for over 12 consecutive hours.

The runtime of a gasoline portable generator on a full tank can vary, depending on factors such as the generator's fuel efficiency and the specific load it's supporting. For instance, if you possess a 5-gallon (18.9 liters) tank and your generator consumes 1.89 liters per hour at your load, it will last approximately 10 hours on a full tank. Nevertheless, these figures can fluctuate, so it's crucial to consult your generator's manual or specifications for precise information regarding its runtime.

The runtime of a battery-powered generator under full load depends on the generator's battery capacity and the load it's serving. Battery-powered generators are typically designed for lighter loads and shorter durations. On average, a portable power station can last anywhere from three to thirteen hours on a fully charged battery. In the case of both systems running at full load, such as a cluster of 120-watt lamps, they can collectively be sustained for a maximum of seven hours.

5.3 Discussion

Contrastingly, based on the data obtained, the perpetual motion generator prototype displayed remarkable success in providing a continuous supply of energy for the light bulb. Unlike the previous prototype discussed, this generator exhibited an impressive ability to sustain its rotation consistently, defying common expectations associated with perpetual motion machines.

The success of this prototype can be attributed to several key factors. Firstly, the generator was strategically designed and operated within an environment that significantly minimized air resistance. It was situated in a controlled and enclosed chamber, effectively shielding it from the disruptive influence of the surrounding air. This isolation from harsh environmental conditions allowed the generator to operate without experiencing air-induced resistance, ensuring a smooth and uninterrupted rotation.

Moreover, meticulous engineering and design modifications played a pivotal role in its success. The generator was expertly crafted to minimize friction between its components. The steel ball bearing and the wheel were optimized for minimal surface contact, significantly reducing friction during rotation [10]. Additionally, the magnet source used in this prototype was precisely calibrated to work in harmony with the spinning steel ball bearing, generating a strong attraction force that surpassed the opposing friction. This meticulous attention to detail allowed the perpetual motion generator to overcome potential resistance factors and maintain its continuous motion.

The result was a perpetual motion generator that efficiently supplied energy to the light bulb without interruptions. This successful outcome challenges the conventional belief that perpetual motion machines are unattainable and highlights the importance of design precision and environmental control in achieving such innovative feats.

To enhance the perpetual motion generator's power output to a level exceeding 120 W, the integration of an auxiliary capacitor circuit is imperative. This circuit acts as an energy storage unit, accumulating surplus power generated by the perpetual motion generator during peak performance. When power demand exceeds the generator's immediate capacity, the capacitor circuit discharges its stored energy, effectively boosting the power output to the required 120 W or beyond. This innovative approach ensures a stable and continuous power supply, making the perpetual motion generator a viable energy source for applications demanding higher wattage levels, all while maintaining its energy-efficient and sustainable characteristics.

6. Conclusion

In conclusion, the study of the perpetual motion generator prototype has revealed important insights into the feasibility and challenges associated with such ambitious endeavors. The prototype discussed earlier serves as a remarkable example of the progress and potential of perpetual motion machines, contrasting the common belief that perpetual motion is unattainable. This prototype demonstrated remarkable success by consistently supplying energy to a light bulb. The achievement can be attributed to a combination of factors, including a controlled environment that minimized air resistance and a meticulously designed system that reduced friction between components. The precise calibration of the magnet source also played a crucial role in ensuring the generator's uninterrupted rotation. While this success is notable, it's essential to acknowledge that perpetual motion machines continue to be a topic of debate and skepticism within the scientific community. The laws of thermodynamics pose significant challenges to the concept of perpetual motion, particularly the law of conservation of energy. Many scientists argue that achieving true perpetual motion is fundamentally impossible, as any system inherently loses energy to factors like friction and air resistance. Nonetheless, the success of this prototype raises intriguing questions about the potential for innovation in the field of perpetual motion. It emphasizes the importance of precision engineering, environmental control, and careful design to minimize energy losses and maximize efficiency. In the broader context, the study of perpetual motion serves as a reminder of the importance of exploring and challenging established scientific boundaries. While the quest for perpetual motion may remain a theoretical endeavor, the journey has the potential to yield valuable knowledge and innovations that may have practical applications in various fields. This prototype's success opens the door to further exploration and inspires researchers to continue pushing the boundaries of what we consider possible in the realm of energy generation.

Acknowledgement

The authors would like to thank the Centre for Diploma Studies, University Tun Hussein Onn Malaysia for its support.

Conflict of Interest

Authors declare that there is no conflict of interests regarding the publication of the paper.

Author Contribution

This journal requires that all authors take public responsibility for the content of the work submitted for review. The contributions of all authors must be described in the following manner:

*The authors confirm contribution to the paper as follows: **study conception and design, data collection:** Raja Iskandar Zulkarnain, Ahmad Zainuddin Azmi, Muhammad Syahmi Danial Khairul Anwar; **analysis and interpretation of results:** Khairulnizam Othman; **draft manuscript preparation:** Raja Iskandar Zulkarnain. All authors reviewed the results and approved the final version of the manuscript.*

References

- [1] N. Padmanabhan, M. Ahmed, and K. Bhattacharya, "Battery Energy Storage Systems in Energy and Reserve Markets," *IEEE Transactions on Power Systems*, pp. 1–1, 2019, doi: <https://doi.org/10.1109/tpwrs.2019.2936131>.
- [2] C. P. Topper, "Nocturnal behaviour of adults of *Heliothis armigera* (Hübner) (Lepidoptera: Noctuidae) in the Sudan Gezira and pest control implications," *Bulletin of Entomological Research*, vol. 77, no. 3, pp. 541–554, Sep. 1987, doi: <https://doi.org/10.1017/s0007485300012025>.

- [3] D. H. Sliney, D. W. Gilbert, and T. Lyon, "Ultraviolet safety assessments of insect light traps," *Journal of Occupational and Environmental Hygiene*, vol. 13, no. 6, pp. 413–424, Apr. 2016, doi: <https://doi.org/10.1080/15459624.2015.1125489>.
- [4] Fahzal Shahrel Fakhurrazzey, W. Noraishah, and Z. Othman, "Performance comparison of 4-Pole Neodymium Magnet Bedini SSG free energy generator," Mar. 2014, doi: <https://doi.org/10.1109/peoco.2014.6814494>.
- [5] M. N. Hidayat, S. P. Chairandy, and F. Ronilaya, "A review on how a Perpetual Motion Machine generates electrical power," *IOP Conference Series: Materials Science and Engineering*, vol. 1098, no. 4, p. 042063, Mar. 2021, doi: <https://doi.org/10.1088/1757-899x/1098/4/042063>.
- [6] N. Yi, "Investigation on the Free Energy Magnet Motors," Faculty of Engineering and Science Universiti Tunku Abdul Rahman, Malaysia, 2011, Thesis. <http://eprints.utar.edu.my/150/1/MH-2011-0705513-1.pdf>
- [7] T. M. Aljohani, "The Flywheel Energy Storage System: A Conceptual Study, Design, and Applications in Modern Power Systems," *International Journal of Electrical Energy*, 2014, doi: <https://doi.org/10.12720/ijoe.2.2.146-153>.
- [8] A. C. Ruoso, N. R. Caetano, and L. A. O. Rocha, "Storage Gravitational Energy for Small Scale Industrial and Residential Applications," *Inventions*, vol. 4, no. 4, p. 64, Oct. 2019, doi: <https://doi.org/10.3390/inventions4040064>.
- [9] X. Chen, J. Zhai, H. Zhang, and Q. Han, "Simulation study on unbalance vibration characteristics of dual-rotor system," *SN Applied Sciences*, vol. 2, no. 8, Jul. 2020, doi: <https://doi.org/10.1007/s42452-020-03237-5>.
- [10] E. Yadav and V. K. Chawla, "An explicit literature review on bearing materials and their defect detection techniques," *Materials Today: Proceedings*, Sep. 2021, doi: <https://doi.org/10.1016/j.matpr.2021.09.132>.