

Investigations on the Cross-hole Sonic Logging Test on Bored Piles at Bridge 29 in Section 8 for East Coast Rail Link (ECRL)

Siti Humairah Mohd Ajis¹, Karthigesu Nagarajoo², Rus Azlizan Mohd Ali³

¹Department of Transportation Engineering Technology, Faculty of Engineering Technology,
Universiti Tun Hussein Onn Malaysia, 84600 Panchor, Johor, MALAYSIA

²Faculty of Engineering Technology,
Universiti Tun Hussein Onn Malaysia, 84600 Panchor, Johor, MALAYSIA

³Section 8, Malaysia Rail Link Sdn. Bhd.
18-L3, Ecosky Commercial Unit, Jalan Ipoh, 68100 Kuala Lumpur, MALAYSIA

*Corresponding Author Designation

DOI: <https://doi.org/10.30880/peat.2023.04.02.127>

Received 28 June 2022; Accepted 13 July 2023; Available online 13 July 2023

Abstract: A bored pile made by cast-in-situ according to the design depth and heads is difficult to conduct quality control of concrete integrity and to check visually if there are any defects detected as it is embedded in the borehole. Therefore, this project is involved in the construction of ECRL project and focuses on the installation of bored pile and Cross-hole Sonic Logging (CSL) test which is evaluate the integrity of bored pile by identify defects inside the bored pile Then, research has been carried out by investigate the factor of concrete defects during bored pile installation. The results of CSL test were collected on bored pile in Bridge 29 at Section 8, Selangor. This project has used a total of five points of test as a reference to conduct research where the test points are P101-1, P101-2, P101-3, P101-4, and P101-5. An analysis is conducted in order to evaluate the integrity of bored piles and identify the defect inside the bored pile. The results show there are 3 piles are detected to have anomalies over total five piles even though all the anomalies are considered minor. Piles that consist of various defects have bigger value of grout volume as the gaps or voids need to be fill with concrete.

Keywords: ECRL, CSL, Bored Piles

1. Introduction

Deep foundation is one of the common foundations in the industry. One of the most frequently used deep foundations are bored piles. Bored piles or drilled shafts are deep, cylindrical, cast-in-place

*Corresponding author: karthi@uthm.edu.my

2023 UTHM Publisher. All rights reserved.

publisher.uthm.edu.my/periodicals/index.php/peat

concrete foundations poured in and formed by a bored excavation. The quality assurance of bored piles must be done because they relatively have high probability of having anomalies and tasks to remake shafts will be difficult to be done [1]. During bored pile installation, several factors can contribute to concrete defects. Table 1 shows some common factors to consider.

Table 1: Factor of defects during bored pile installation

Factor	Description
Concrete Mix Design	If the mix design is incorrect or inadequate, it can lead to various defects such as low strength, excessive bleeding, or excessive shrinkage.
Reinforcement Placement	Insufficient cover, misalignment, or improper spacing of reinforcement bars can lead to reduced structural integrity and durability.
Concrete Placement and Compaction	Inadequate vibration, improper pouring techniques, or insufficient compaction can lead to voids, honeycombing, or poor bond between the concrete and the surrounding soil or existing structure.
Curing Conditions	Inadequate or improper curing, such as insufficient moisture or temperature control, can result in low strength, cracking, or surface defects.
Ground Conditions	Soft or unstable ground can lead to settlement, misalignment, or bulging of the pile, affecting the integrity of the concrete.

Using one of the Non-Destructive Testing (NDT) can be a very valuable tool for assessing the integrity and quality of bored piles or drilled shafts without causing damage to the structure [2] [3]. Cross - hole sonic logging (CSL) test is one of the most accurate pile integrity tests to determine the integrity of deep foundation elements. CSL sends ultrasonic pulses through the concrete from one probe to another probe presents in a pile and detects the structural integrity based on the receiver waves [4].

1.1 Bored Piles

A bored pile is a cast-in-place concrete pile which means the pile is cast in the construction site while other concrete pile foundations such as spun pile and reinforced concrete square pile foundations use pre-cast concrete piles [5]. Bored piling is a common method used for constructing deep foundations in various types of construction projects, including bridges, tall buildings, and industrial complexes [6]. Mostly bridges and stations for ECRL project are used bored pile concrete foundation.

The installation of bored pile involves boring the hole, fabrication of steel cage, installation of steel cage, installation of steel casing, base cleaning, pouring concrete and testing for the bored pile. Figure 1 shows the bored pile workflow chart in ECRL project [7]. After the installation of bored pile, the integrity of the pile needs to be evaluated either using Low Dynamic testing or CSL testing.

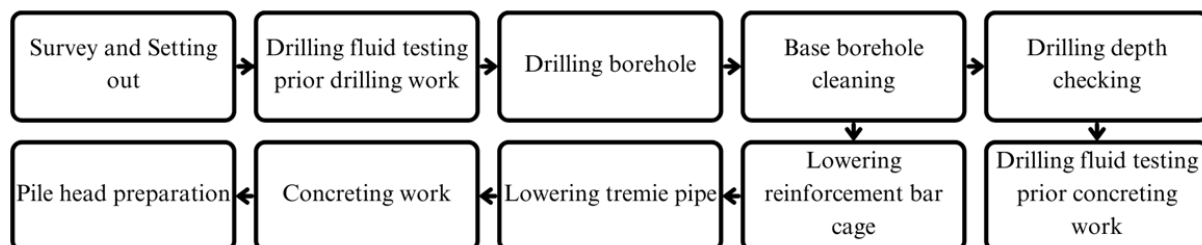

Figure 1: Flow chart of bored pile construction

1.2 Cross-hole Sonic Logging

CSL is NDT method that is commonly used for bored piles or drilled shafts [8]. It is categorized as an ultrasonic testing method, which involves the use of high-frequency sound waves to detect defects or anomalies in the structure [9]. CSL main principle is velocity of wave that is going through the concrete is varied proportionally with density of material and the elastic constant [10]. The velocity approximation can be calculated as function of distance and time from measuring travel time of a signal between transmitter and receiver [11] [12].

CSL test has several advantages over other non-destructive testing (NDT) methods and conventional testing methods which is it can detect small defects such as voids or cracks and provide detailed information about the thickness and diameter of the pile or shaft. CSL test also does not damage the pile or shaft being tested therefore, a safer and more cost-effective alternative to destructive testing methods. CSL can detect defects or anomalies early on before they become major problems that could require costly repairs or even compromise the safety of the structure [13].

The primary functionality for the cross-hole sonic logging test use in ECRL project has been considered in the international standard in the subject: ASTM D6760 – 08. In this standard, the test method covers procedures for checking the homogeneity and integrity of concrete in deep foundation elements. This standard also stated that CSL test “measures the propagation time and relative energy of an ultrasonic pulse between parallel access ducts (cross hole) or in a single tube (single hole) installed in the deep foundation element” [14].

2. Methodology

2.1 Methodology

In this project, the CSL test was conducted by contractor utilizing the bored pile in ECRL project which is located at Bridge 29 in Section 8. The goal was to evaluate the pile integrity of the bored pile for a better improvement in installing a bored pile. The required information on the CSL test is determined to guarantee that the project went smoothly. The interpretation of the results is discussed with the supervisor for a better understanding of this project aside from the previous research paper.

2.2 Equipment



Figure 2: Equipment for CSL test

There are three basic equipment to conduct the CSL test as shown in Figure 2 [15]. First equipment is cross-hole analyzer which is to measure the transmit time of ultrasonic pulses transmitted between pairs of access tubes or sensor installed in parallel holes. The analyzer can calculate the wave velocity

and assess the quality and uniformity of the material in the bored pile by comparing the measured transit time with known distances between access tubes.

Then, as cross-hole analyzer needs to transmit ultrasonic pulse and convert into electrical signal, the use of transmitter and receiver is a must to allow acoustic waves to pass through and reach the sensors embedded within the transducer without significant distortion or reflections. Lastly, a depth encoder or known as probe is an essential equipment that helps determine the depth or position of the transmitter and receiver within an access tube to ensures the depth measurement is synchronized with the data acquisition process.

2.3 Evaluation of Pile Integrity

The pattern of signal profiles is evaluated as the precedent criteria and followed by the depth for ECRL project. A severe distortion of the signal curve will indicate a poor homogeneity of concrete. For a consistent transmission of signal over depth, it is called “acceptable”. For a relatively minor reduction and slight delay, it considered as the “minor anomaly”, but it does not necessarily indicate a flaw or defective pile as there are many factors can cause this “minor anomaly”. For a severe distortion in signal or loss of signal at certain depth, it can be classified as the “major anomaly” [16].

Values of first arrival time (FAT) and relative energy for the acceptable, minor anomaly and major anomaly classification for interpretation of the results shall be referred as per Table 1 which indicates the criteria for evaluation of the concrete from the CSL test. Flaws should be addressed if they are indicated in more than 50% of the profiles. Defects must be addressed if they are indicated in more than one profile. If the defects or flaws indicated over the whole cross-section usually it requires repair or replacement [16].

Table 1: Range of FAT and energy reduction

Concrete Quality	FAT Increase (%)		Energy Reduction (dB)
Good	0 to 10	and	< 6
Anomaly	11 to 20	and	< 9
Poor/Flaw	21 to 30	or	9 to 12
Poor/Defect	> 31	Or	> 12

3. Results and Discussion

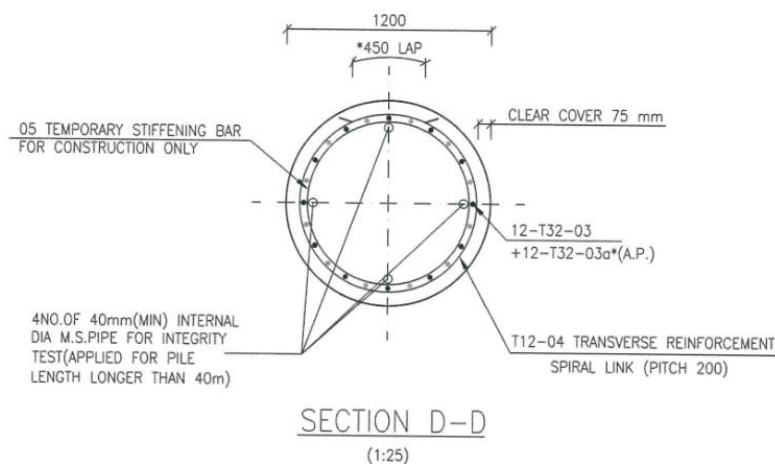

Figure 4: Cross section of top view of pile P101

The ultrasonic signal of compression waves is analyzed between four parallel pipes. Therefore, four pipes were already installed when the installation of bored pile since the number and position of the pipes recorded on the construction drawings as shown in Figure 4. The ultrasonic profile of CSL test for point P101-1, P101-2, P101-3, P101-4 and P101-5 are analyzed based on the evaluation of pile integrity and the record of grouting. Prior to this project, this test is conducted on the bored piles of length 40 m or above or pile diameter equals to or more than 1.5 m.

3.1 Cross-Hole Sonic Logging Test

Table 2: Summary of CSL test results for pile P101

Point	Profile	Length of Pile (m)	FAT Increase (%)	Energy Reduction (dB)	Reduction Energy Location (m)	Classification
P101-1	1-2	46.73	0 to 10	< 6	15.2	Acceptable
	1-3	46.73	0 to 10	< 6	11.2	Acceptable
	1-4	46.73	0 to 10	< 6	16.0	Acceptable
	2-3	46.73	0 to 10	< 6	21.0	Acceptable
	2-4	46.73	0 to 10	< 6	11.2	Acceptable
	4-3	46.73	0 to 10	< 6	25.0	Acceptable
P101-2	1-2	46.87	0 to 10	< 9	23.6	Minor anomaly
	1-3	46.87	0 to 10	< 6	10.8	Acceptable
	1-4	46.87	0 to 10	< 6	33.6	Acceptable
	2-3	46.87	0 to 10	< 6	23.6	Acceptable
	2-4	46.87	0 to 10	< 9	11.0	Minor anomaly
	4-3	46.87	0 to 10	< 6	11.0	Acceptable
P101-3	1-2	47.93	0 to 10	< 6	23.8	Acceptable
	1-3	47.93	0 to 10	< 6	44.0	Acceptable
	1-4	47.93	0 to 10	< 6	11.0	Acceptable
	2-3	47.93	0 to 10	< 6	25.4	Acceptable
	2-4	47.93	0 to 10	< 6	25.4	Acceptable
	4-3	47.93	0 to 10	< 6	25.2	Acceptable
P101-4	1-2	48.24	0 to 10	< 6	43.6	Acceptable
	1-3	48.24	0 to 10	< 9	13.4	Minor anomaly
	1-4	48.24	0 to 10	< 6	13.2	Acceptable
	2-3	48.24	0 to 10	< 6	13.6	Acceptable
	2-4	48.24	0 to 10	< 9	13.6	Minor anomaly
	4-3	48.24	0 to 10	< 9	13.6	Minor anomaly
P101-5	1-2	48.35	0 to 10	< 9	15.4	Minor anomaly
	1-3	43.55	0 to 10	< 6	16.4	Acceptable
	1-4	48.35	0 to 10	< 6	15.6	Acceptable
	2-3	43.55	0 to 10	< 9	16.4	Minor anomaly
	2-4	48.35	0 to 10	< 6	15.4	Acceptable
	4-3	43.55	0 to 10	< 6	16.4	Acceptable

Based on the Table 2, point P101-1 in configuration of 1-2 the delay of FAT and reduction of energy were detected at a depth of 15.2 m. Then, the delay of FAT and reduction of energy in configuration 1-3 were detected at the depth between 11.2 m while for configurations 1-4 is 16.0 m of depth. However, the reduction energy for all configurations in point P101-1 is not more than 6 dB which means the pile concrete quality can be classified as 'Good'.

The delay of FAT and reduction of energy shown at the depth between 23.6 m in configuration 1-2 for point P101-2. In configuration 2-4, the delay of FAT and energy reduction were start at 10 m and consecutively at the depth of 11 m, 20 m, 24 m, 27 m and 34 m. The energy reduction in both

configuration is below 9 dB which interpret the existence of defects. The concrete quality for pile at point P101-2 can be classified as ‘Minor Anomaly’ that results from various of factors.

Table 2 shows that point P101-4 has most configurations that classified as ‘Minor Anomaly’. Configurations 1-3, 2-4, 4-3 has value less than 9 dB of energy reduction which refers to existence of defects. The defects can be interpreted as there are gaps or voids in the concrete and the pile at point P101-4 need to monitor or conduct the CSL test again to make sure the pile is testing in sufficient curing time.

3.2 Grouting

Table 3 below shows the grouting construction record for pile test P101-1, P101-2, P101-3, P101-4 and P101-5. Based on Table 3, the grout volume at point P101-4 is higher than other point. This is because point P101-4 needs more concrete to fill the defects or voids in the pile since CSL test shows point P101-4 have more defects than other piles. The lowest recorded grout volume is in point P101-1 and point P101-3 as all the configurations for these two points shows the energy reduction are lower than 6 dB and the FAT delay in normal range.

Table 3: Grouting construction record

Point	Grouting Time (Hours)		Grout Volume (m ³)
	Starting Time	Ending Time	
P101-1	0930	0945	0.236
P101-2	0945	1000	0.242
P101-3	1000	1015	0.236
P101-4	1015	1030	0.254
P101-5	1030	1045	0.244

4. Conclusion

To sum up, the three objectives of this CSL test in ECRL project at Bridge 29 has been achieved and is proved as a testing to evaluate the pile integrity of the bored pile which can be applied not only for ECRL project but also other construction projects. A thorough review on installation of bored piles, and CSL test in ECRL project has been investigate. Also, the standards and approaches through the design of bored pile utilizing a variety of tools has been analyzed. The evaluation of pile integrity based on other standards and from past studies has been presented. In conclusion, the study of CSL test on bored piles has shed light on the importance of the pile integrity to ensure the structural integrity and load-bearing capacity based on the information of the thickness and diameter of the pile. The significance factors of defect of flaw in CSL test can be cause from construction errors, forming of air pocket during curing process, poor bonded concrete layers and cracks.

Acknowledgement

The authors would like to express their gratitude to Malaysia Rail Link Sdn. Bhd. For cooperating on this project. This project was conducted as part of a project sponsored by the Universiti Tun Hussein Onn Malaysia.

References

- [1] D. Sibit and G. Handayani, “The crosshole sonic logging (CSL) measurement system to measure the quality of physical model of bored pile,” *Journal of Physics: Conference Series*, vol. 739, p. 012051, 2016. doi: <https://doi.org/10.1088/1742-6596/739/1/012051>

- [2] A. Tulebekova, N. Shakirova, A. Zhankina, and Y. Muratov, “Non-destructive testing of bored piles,” *Technobius*, vol. 1, no. 3, p. 0002, Sep. 2021, doi: <https://doi.org/10.54355/tbus/1.3.2021.0002>.
- [3] G. Likins, F. Rausche, K. M. Webster, and A. Klesney, “Defect analysis for CSL testing,” Oct. 2007, doi: [https://doi.org/10.1061/40902\(221\)3](https://doi.org/10.1061/40902(221)3).
- [4] Alireza Kordjazi, J. T. Coe, and M. Afanasiev, “Nondestructive evaluation of drilled shaft construction anomalies using full waveform tomography of simulated crosshole measurements,” vol. 40, no. 1, Dec. 2020, doi: <https://doi.org/10.1007/s10921-020-00728-8>.
- [5] “Bored Pile Foundation Techniques and Benefits,” LiveAbout. <https://www.liveabout.com/bored-pile-advantages-also-referred-as-drilled-shafts-844753>
- [6] C. Facilitator, “Different types of pile foundation and their use in construction,” *Constro Facilitator*, Sep. 26, 2020. <https://constrofacilitator.com/different-types-of-pile-foundation-and-their-use-in-construction/>
- [7] H. R. Pasin, S. Ismanti, and H. C. Hardiyatmo, “The stability analysis of the bored pile foundation as liquefaction hazard mitigation at the university of tadulako reconstruction project,” vol. 1184, no. 1, pp. 012001–012001, May 2023, doi: <https://doi.org/10.1088/1755-1315/1184/1/012001>.
- [8] S. K. Bagui, S. K. Puri, and K. Subbiah, “Cross hole sonic test results for analysis of pile load test,” *Advances in Bridge Engineering*, vol. 1, no. 1, Dec. 2020, doi: <https://doi.org/10.1186/s43251-020-00017-4>.
- [9] “Non-Destructive Testing,” *Instrumentation Reference Book*, pp. 567–592, 2010, doi: <https://doi.org/10.1016/b978-0-7506-8308-1.00031-0>.
- [10] K. Beckhaus and H. Heinzelmann, “Ultrasonic integrity testing for bored piles -a challenge.” Available: https://www.ndt.net/article/ndtce2015/papers/027_Beckhaus_Karsten_Nachmeldung.pdf
- [11] R. E. Sheriff and L. P. Geldart, *Exploration seismology*. Cambridge; New York: Cambridge University Press, 1995.
- [12] R. E. Sheriff, “Encyclopedic Dictionary of Applied Geophysics,” Jan. 2002, doi: <https://doi.org/10.1190/1.9781560802969>.
- [13] S. Rodriaan, V. T. Frits, B. Wout, S. Evert and N. Ernst, “Detection of anomalies in diaphragm walls with crosshole sonic logging,” vol. 51, no. 4, pp. 369–380, Apr. 2014, doi: 10.1139/cgj-2013-0204.
- [14] “Test method for integrity testing of concrete deep foundations by ultrasonic crosshole testing,” doi: <https://doi.org/10.1520/d6760-08>.
- [15] “Crosshole sonic logging with the crosshole analyzer (CHAMP-XV),” *Pile Dynamics*. <https://www.pile.com/products/champ-xv/> (Accessed Jun. 27, 2023).
- [16] C. C. Construction. “Eclr-s1-br-ms-0026-rev 01-method statement for bored pile crosshole sonic logging test” Malaysia: China Communications Construction.