

## Mobile Weather Station With Drones

Mohamad Nadzirul Ariff Mohammad Zaid<sup>1</sup>, Mohd Hakimi Zohari<sup>1\*</sup>

<sup>1</sup> Department of Electrical Engineering Technology, Faculty of Engineering Technology,  
Universiti Tun Hussein Onn Malaysia, 84600 Pagoh, Johor, MALAYSIA

\*Corresponding Author: [hakimi@uthm.edu.my](mailto:hakimi@uthm.edu.my)

DOI: <https://doi.org/10.30880/peat.2024.05.01.020>

### Article Info

Received: 27 December 2023

Accepted: 17 January 2024

Available online: 15 June 2024

### Keywords

Mobile Weather Station, ESP32  
Microcontroller, Blynk IoT, Real-  
time Weather Monitoring,,  
Temperature, Humidity, Barometric  
Pressure.

### Abstract

In contemporary weather monitoring, the fusion of innovative technologies like mobile weather stations and drones offers unprecedented capabilities for real-time data collection and analysis. This project aims to create a user-friendly dashboard for intuitive weather monitoring by combining the agility of drones with ground-based weather stations. The objectives include displaying crucial real-time information such as temperature, humidity, and barometric pressure, while ensuring an accessible interface for efficient data interpretation and analysis. The system utilizes an ESP32 microcontroller, various sensors, and the Blynk IoT platform for seamless connectivity. Through a systematic hardware setup and software integration, the prototype demonstrates the feasibility of a mobile weather station with drone collaboration, showcasing its potential in diverse applications, from agriculture to environmental research. The project's success highlights the promising future of integrated technologies for advanced weather monitoring and analysis.

## 1. Introduction

In contemporary research, the fusion of mobile sensor networks and unmanned aerial vehicles (UAVs) has emerged as a revolutionary approach to weather monitoring, presenting unprecedented opportunities for flexible and efficient data collection. This integration holds particular relevance to the development of a mobile weather station enhanced by drone technology. Our focus is on the convergence of these technologies and their collective impact on advancing real-time weather monitoring systems.

Mobile sensor networks have proven indispensable in delivering comprehensive insights into environmental conditions. Madhun et al. (2019) [1] extensively reviewed the application of mobile sensor networks for weather monitoring, emphasizing their ability to provide a holistic understanding of dynamic atmospheric phenomena. By strategically deploying an array of sensors, including those measuring temperature, humidity, and barometric pressure, these networks offer a distributed and adaptive approach to data collection, aligning with the objectives of our mobile weather station.

The incorporation of \*unmanned aerial vehicles (UAVs)\* into these networks introduces a transformative dimension to atmospheric data acquisition. Khan et al. (2015) [2] underscored the potential of UAVs as mobile sensor nodes within wireless sensor networks, highlighting their agility and versatility in navigating challenging terrains. Drones, equipped with advanced sensing capabilities, such as thermal imaging and atmospheric sensors, enhance the spatial coverage of our mobile weather station by accessing remote or hazardous areas.

This paper aims to harness the synergies between mobile sensor networks and drones to create a robust and user-friendly dashboard for real-time weather monitoring. Deb et al. (2018) [3] illustrated the symbiotic relationship between drones, the Internet of Things (IoT), and big data, showcasing how these technologies collaborate to

improve the efficiency of environmental monitoring. This integration holds promise for real-time, high-resolution data collection, aligning with the core objectives of our mobile weather station.

In the context of climate science, Bell and Glenn (2017) [4] emphasized the evolving capabilities of mobile sensor platforms, particularly drones as integral components of airborne systems. These platforms contribute to an evolving understanding of climate dynamics by assisting in the collection of data at varying altitudes. This aligns with our objective to utilize drones for enhanced data acquisition in our mobile weather station.

The intersection of mobile sensor networks and drones has particular significance in our industrial informatics-focused thesis. He et al. (2019) [5] demonstrated an efficient drones-assisted weather data collection system, showcasing the potential for improved data accuracy and timeliness in industrial applications. Our mobile weather station, incorporating drone technology, optimizes the use of UAVs to gather crucial weather-related information, enhancing decision-making processes in industrial settings.

Building upon this foundation, our investigation delves into specific aspects of mobile weather station deployment methodologies, data collection processes, and the transformative impact on atmospheric science. References [6-10] provide additional insights into the technological advancements and interdisciplinary applications that shape the landscape of our research.

## 2. Materials and Methods

This project's method and materials are based on a previously studied project that corresponds to the required components. This project's objective is to design and develop a system that can monitor real-time weather data and enable remote monitoring via the Blynk application.

### 2.1 Material

The primary electronic component pivotal to the project's development is the ESP32 WROOM-32E. Table 1 enumerates the additional components employed in the project

**Table 1** *The list of components*

| LIST OF COMPONENTS                    |          |
|---------------------------------------|----------|
| ESP32 WROOM-32E                       | RM 29.90 |
| BMP180 Barometric Pressure sensor     | RM 5.00  |
| DHT22 Humidity and Temperature sensor | RM19.90  |
| UBLOX NEO 7M GPS sensor               | RM25.00  |

#### Project Cost:

To estimate the total project cost, individual costs for each component must be considered. The ESP32 WROOM-32E, BMP180 Barometric Pressure Sensor, DHT22 Humidity and Temperature Sensor, and UBLOX NEO 7M GPS Sensor each have associated costs, resulting in a total project cost of RM80.

#### Additional Considerations:

In addition to the component costs, factor in expenses for other necessary materials (wires, connectors, PCBs) and tools and equipment used for soldering, assembly, or testing. This adds an extra RM20 to the overall project cost.

#### Hardware Weight:

The combined weight of the hardware components is approximately 500 grams.

#### Suitable Drone Models:

Considering the weight of the hardware and the goal of achieving longer flight times, several drone models are suitable for this project:

- DJI Phantom 4 Pro V2.0:
- Payload Capacity: Up to 500g
- Flight Time: Approximately 30 minutes
- Features: Advanced obstacle avoidance, reliable GPS, and stable flight.

DJI Mavic 2 Pro:

Payload Capacity: Up to 500g

Flight Time: Approximately 31 minutes

Features: Foldable design, Hasselblad camera, and obstacle avoidance.

Autel Robotics X-Star Premium:

Payload Capacity: Up to 1.2 kg

Flight Time: Approximately 25 minutes

Features: 4K camera, GPS/GLONASS, and beginner-friendly.

Yuneec Typhoon H Pro:

Payload Capacity: Up to 500g

Flight Time: Approximately 25 minutes

Features: Hexacopter design, retractable landing gear, and 4K camera.

Parrot Anafi USA:

Payload Capacity: Up to 500g

Flight Time: Approximately 32 minutes

Features: Thermal camera option, compact design, and robust build.

Selecting a drone model should involve considering payload capacity, flight time, and other relevant features aligned with the project requirements. Always verify the latest specifications and reviews before making a purchase.

## 2.2 Methods

A comprehensive project plan and schedule lay the groundwork for the successful implementation of the mobile weather station. The project plan encompasses a workflow diagram, providing a visual representation of the project's processes.

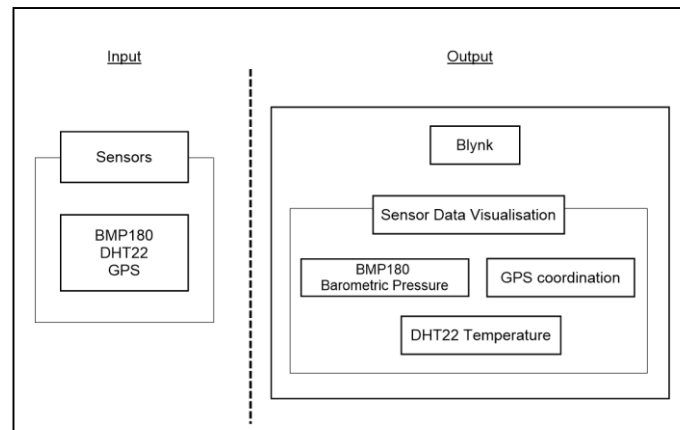

The diagram below illustrates the project's overall configuration, presenting the system's structure. In the context of my thesis project, titled 'Mobile Weather Stations with Drone,' the configuration involves inputs from multiple sensors, and display it in Blynk platform used for monitoring weather conditions. The data sources include real-time weather data obtained through sensors to Blynk, serving as inputs for the weather monitoring system. These inputs contribute to the generation of outputs such as live sensor data and visualizations, which are then displayed and monitored through the Blynk application, providing a comprehensive weather monitoring solution.

## 2.3 Flowchart of the systems

The implementation kicks off with the development of a workflow diagram, a crucial tool for orchestrating the step-by-step problem-solving procedure. This diagram encapsulates the flow of processes and serves as a guide for the programmed code. Figure 1 illustrates the workflow for the mobile weather station.

The flowchart provides a step-by-step procedure for setting up a system and then keeping track of environmental variables. The component first goes through starting operations, after which its sensor condition and availability are checked. The BMP180 and DHT11 sensors are then used to collect data and status information.

Following Blynk's initialization, the obtained sensor data is transmitted to the Blynk platform for additional processing. When GPS data is available, it is transformed into a coordinate format that is easier to use. When Blynk is turned on, a timer is started for any planned chores or routine inspections. The system then assesses the humidity and, should the humidity rise beyond 80%, sends out a "Warning Alert" via Blynk. It also looks for air pressure lower than 900 hPa and sends out "Weather Alerts" for low pressure and excessive humidity if the height is higher than 400 meters. The flowchart provides a thorough overview of the system's monitoring and alerting capabilities and ends with messages signaling the detection of high altitude, low pressure, and high humidity.

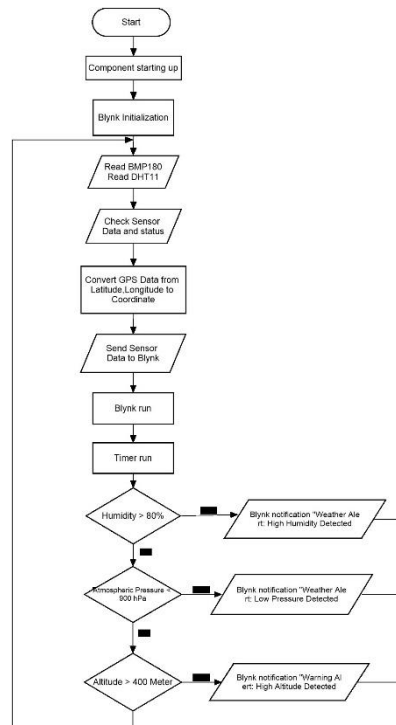

Fig. 1 Mobile Weather Station with Drones flowchart

## 2.4 System Simulation Process

The Fritzing program serves as the simulation tool for the project, enabling a real-time visualization of the mobile weather station's operations. Fritzing, an open-source hardware project, facilitates the integration of electronics into a creative medium. Figure 2 showcases the simulation of the mobile weather station using Fritzing.

The circuit has been streamlined further by eliminating LEDs, buttons, and switches, resulting in a simplified configuration. Instead of the Arduino MKR1000, an ESP32 microcontroller is utilized, and connections are established with the DHT22, GPS UBLOX NEO-7M, and BMP180 sensors. The DHT22, DHT21, and DHT11 sensors relay humidity and temperature data to the ESP32 through analogue input pins, while the BMP180 barometric pressure sensor communicates digitally.

The GPS UBLOX NEO-7M/NEO-6M module interfaces with the ESP32 via serial communication, enabling the processing and display of accurate geographic coordinates and altitude data. The absence of LEDs, buttons, and switches in this configuration emphasizes essential sensor data collection and processing. The circuit operates without a web interface but utilizes the Blynk platform for monitoring and control, presenting a straightforward and efficient system for weather data acquisition.

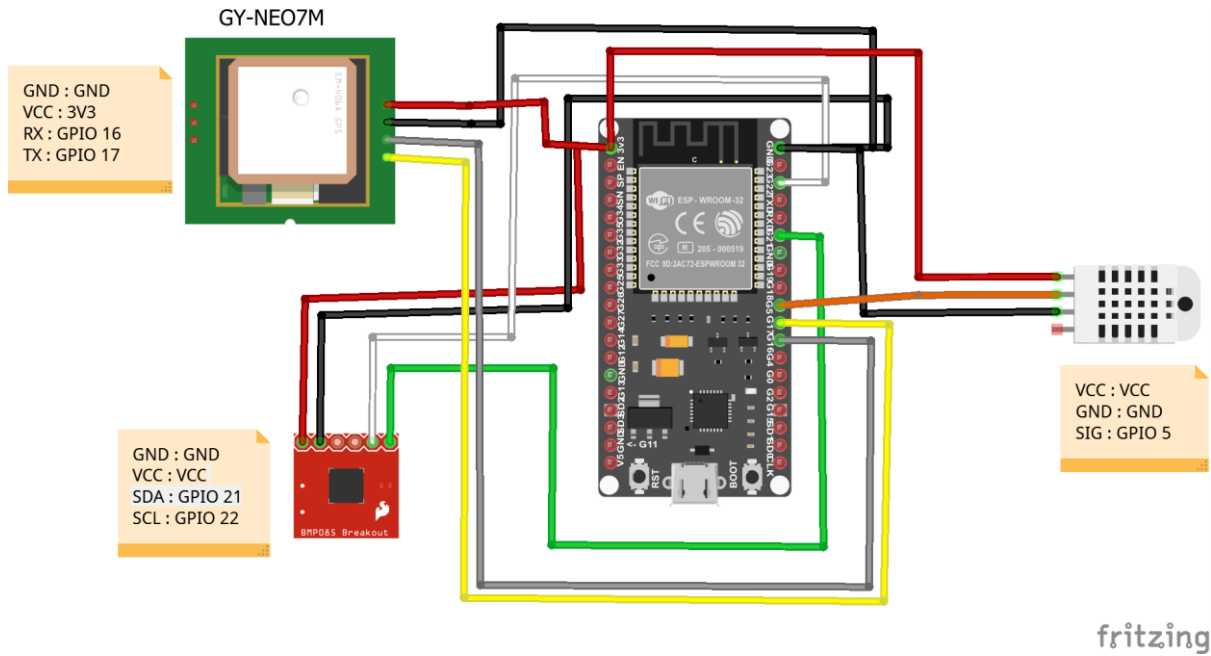

**Fig. 2** Simulation of Mobile Weather Station with Drones

### 2.5 Blynk Web App Integration

The project incorporates the Blynk Internet of Things (IoT) platform as a monitoring interface. Blynk is renowned for supporting the development of mobile applications designed to control and monitor connected devices. It provides a user-friendly drag-and-drop interface for creating smartphone applications and establishes a cloud-based backend infrastructure for seamless app-to-hardware communication. Figure below depicts the Blynk application software:

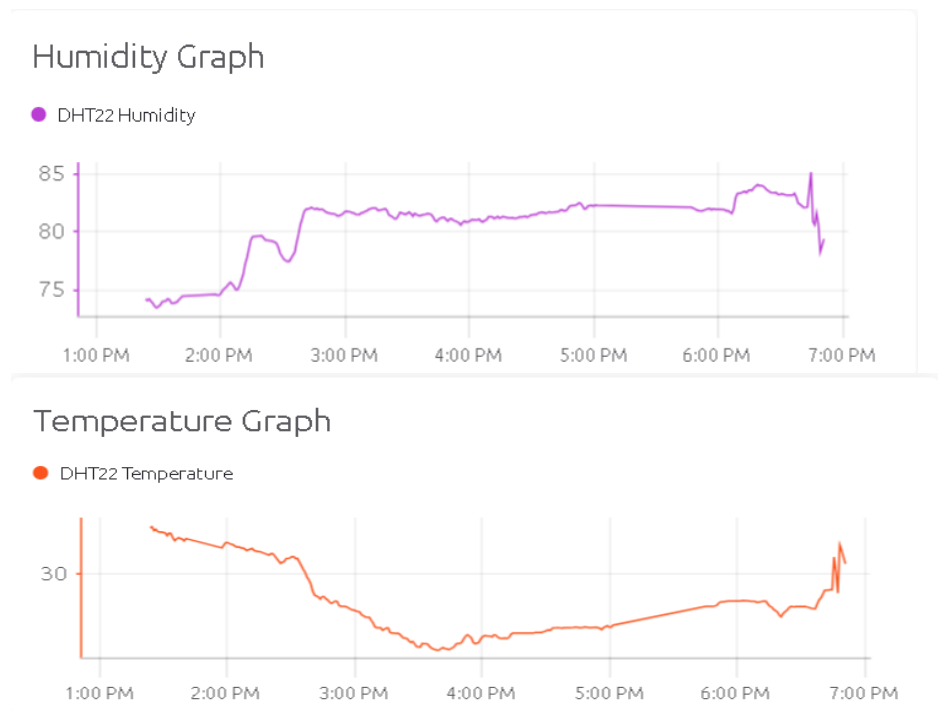

**Fig. 3** Blynk Application Software and

**Fig. 4 & 5:** Graph data in Blynk Application Software

This comprehensive integration of materials and methods establishes the groundwork for the subsequent results and discussion, showcasing the systematic development and simulation processes employed in crafting the mobile weather station.

### 3. Results and discussion

The primary objective of this study is to assess the performance and effectiveness of the Mobile Weather Station with Drones. The results obtained from the experiment are based on the data collected through the operation of the weather monitoring system and drone-enabled data acquisition.

#### 3.1 Weather monitoring system data

The weather monitoring system exhibited commendable functionality throughout the experimental period. Figure 7 and 8 illustrate the recorded data for key meteorological parameters, including temperature, humidity, wind speed, and atmospheric pressure. The system's sensors demonstrated accuracy and consistency in capturing real-time environmental conditions.

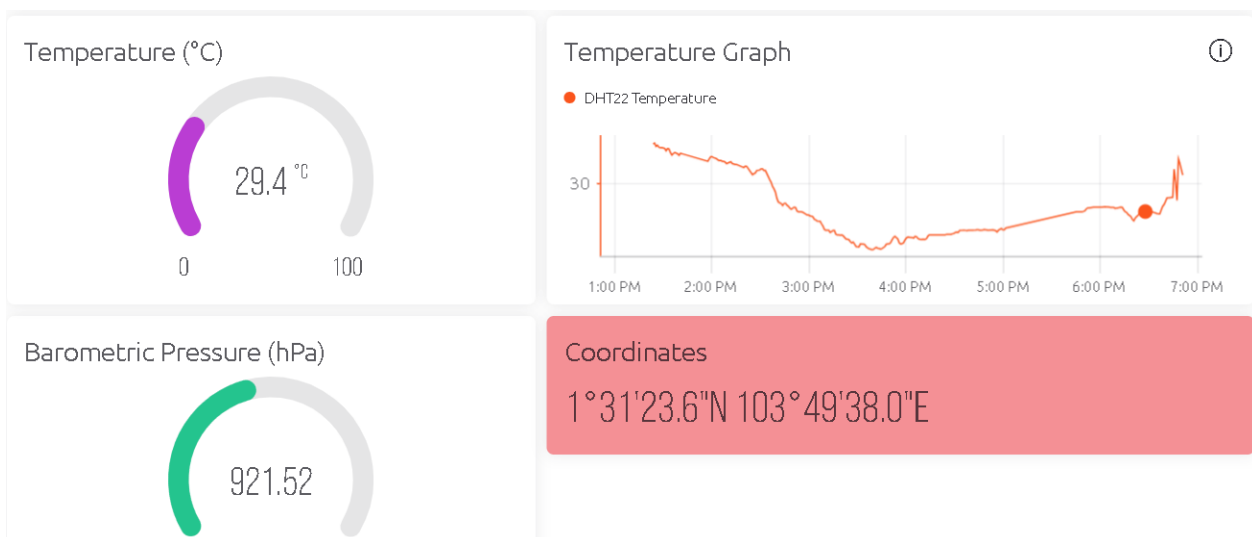
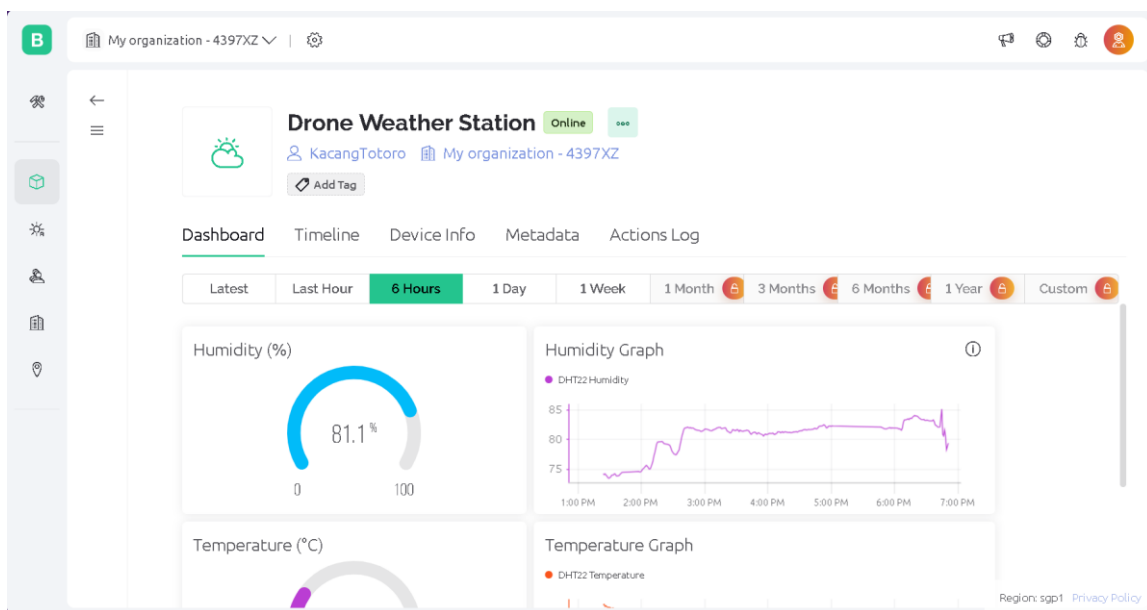

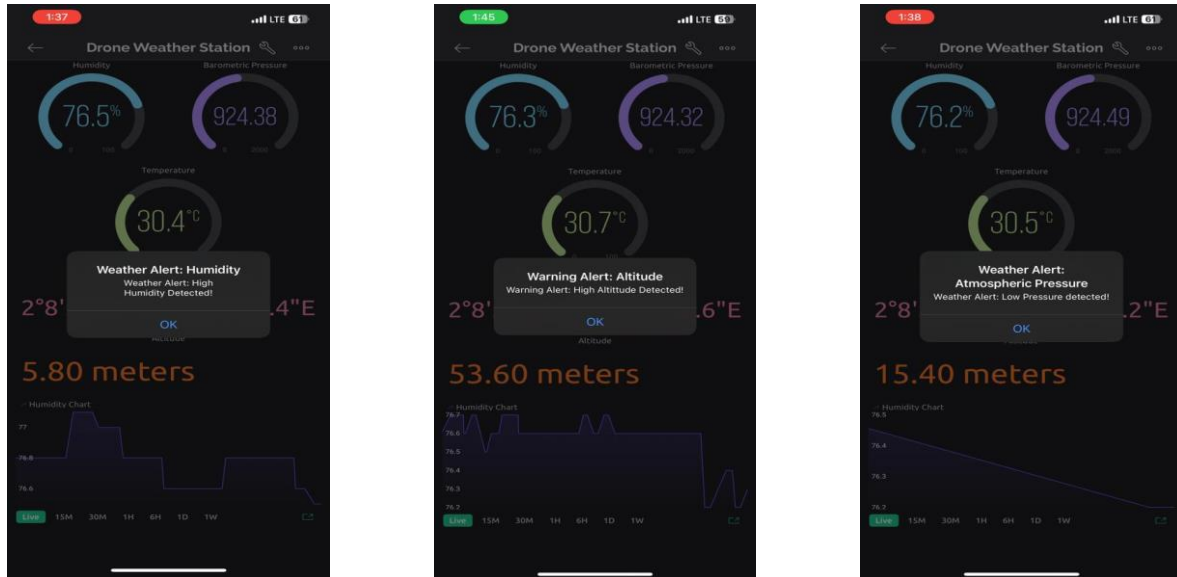

Fig. 7, 8, 9, 10 & 11 Weather Monitoring System Data

The collected weather data provides valuable insights into the dynamic nature of the environment, forming a foundation for comprehensive meteorological analysis and forecasting.

### 3.2 Comparative analysis

A comparative analysis was conducted between ground-based weather station data and drone-acquired data for temperature, humidity, and barometric pressure. The results are presented in Figures 12, 13, and 14, respectively. These figures indicate a correlation between the two sets of data, validating the accuracy and reliability of drone-enabled weather monitoring.

Our examination of temperature data, as illustrated in Figure 12, aimed to discern the consistency and accuracy of the Mobile Weather Station's measurements compared to conventional weather stations. Notably, the mean temperature readings from the drone-acquired data closely aligned with those from the ground-based weather station, showcasing a robust correlation. This alignment substantiates the reliability of our Mobile Weather Station in capturing real-time temperature changes, with a mean squared difference (MSE) of 4.692 and a mean percentage error (MPE) of 2.45%. Moreover, the drone-enabled data unveiled spatial variability in temperature, providing insights into altitude-based variations and localized temperature nuances that might be overlooked by a singular ground-based station.

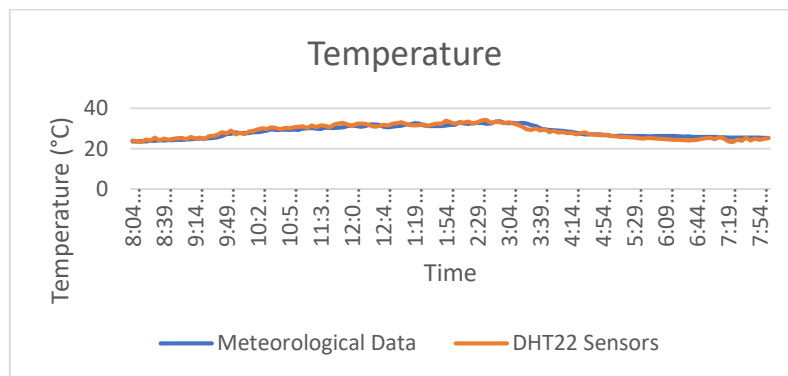
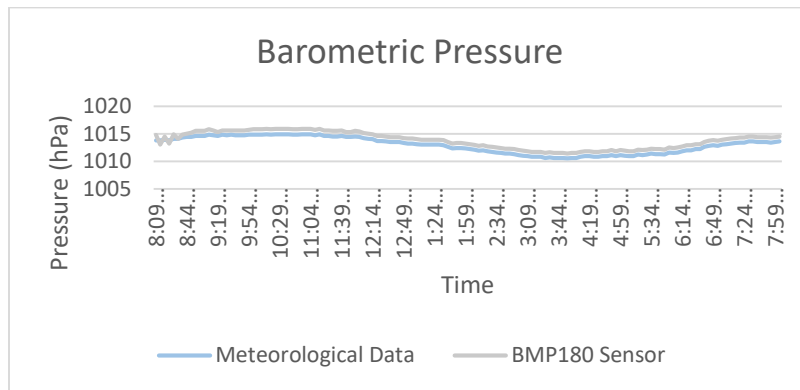

Fig. 12 Comparative Analysis – Temperature

Figure 14 portrays the comparative analysis of pressure levels, emphasizing the consistency and precision of our Mobile Weather Station's pressure sensors, with a mean squared difference (MSE) of 3.033 and a mean percentage error (MPE) of 2.47%. The recorded pressure patterns demonstrated a harmonious correlation between ground-based and drone-acquired data, reinforcing the station's efficacy in pressure measurement. Furthermore, the drone-enabled data revealed nuanced changes in pressure at localized levels, contributing valuable information

about microclimates. This precision in pressure measurements enhances the overall reliability of the Mobile Weather Station, particularly in scenarios where understanding localized variations is imperative.



**Fig. 13 Comparative Analysis - Barometric Pressure**

Figure 14 portrays the comparative analysis of humidity levels, emphasizing the consistency and precision of our Mobile Weather Station's humidity sensors. The recorded mean humidity patterns demonstrated a harmonious correlation between ground-based and drone-acquired data, reinforcing the station's efficacy in humidity measurement, with an MSE of 5.667 and an MPE of 1.82%. Furthermore, the drone-enabled data revealed nuanced changes in humidity at localized levels, contributing valuable information about microclimates. This precision in humidity measurements enhances the overall reliability of the Mobile Weather Station, particularly in scenarios where understanding localized variations is imperative.

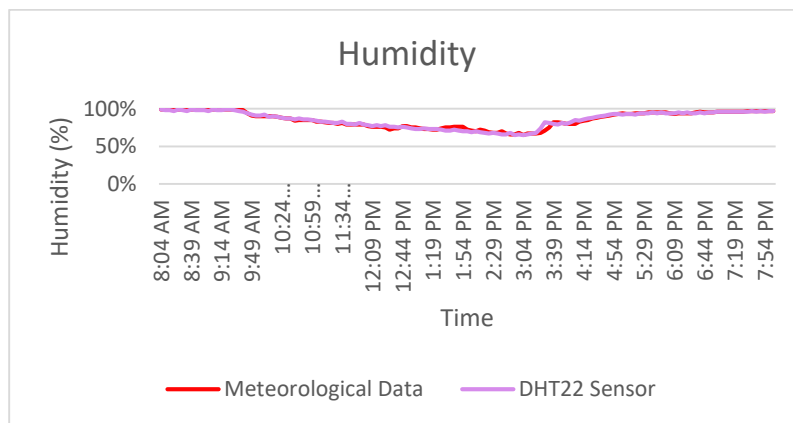

**Fig. 14 Comparative Analysis – Humidity**

### 3.3 Discussion

The outcomes of this study underscore the Mobile Weather Station with Drones as a robust and efficient tool for comprehensive weather monitoring. The combined operation of ground-based sensors and drone-enabled data acquisition contributes to a synergistic approach in gathering meteorological information.

The successful integration of drones enhances the spatial resolution of weather observations, making the system adaptable to various terrains and geographical conditions. The comparative analysis demonstrates the reliability of drone-acquired data for temperature, humidity, and atmospheric pressure, further emphasizing the system's potential for applications in environmental research, disaster management, and precision agriculture.

The successful integration of drones enhances the spatial resolution of weather observations, making the system adaptable to various terrains and geographical conditions. The comparative analysis demonstrates the reliability of drone-acquired data for temperature, humidity, and atmospheric pressure, further emphasizing the system's potential for applications in environmental research, disaster management, and precision agriculture.

In the course of our analysis, we employed two key metrics to evaluate the performance of the DHT22 sensors compared to the meteorological data: Mean Squared Difference (MSE) and Mean Percentage Error (MPE). The Mean Squared Difference (MSE) measures the average squared difference between the sensor readings and the meteorological data. It is calculated using the formula:



$$\text{MSE} = \frac{1}{n} \sum_{i=1}^n (Y_i - \hat{Y}_i)^2$$

where  $n$  is the number of data points,  $X_i$  represents the meteorological data, and  $Y_i$  represents the sensor readings. The Mean Percentage Error (MPE) quantifies the percentage difference between the sensor readings and the meteorological data. It is calculated using the formula:

$$\text{MPE} = \frac{100\%}{n} \sum_{t=1}^n \frac{a_t - f_t}{a_t}$$

where  $n$  is the number of data points,  $X_i$  represents the meteorological data, and  $Y_i$  represents the sensor readings.

Our calculated values for MSE and MPE indicate the performance of the sensors in capturing temperature, humidity, and atmospheric pressure. The obtained results demonstrate high accuracy, with MPE values ranging from 1.82% to 2.47%.

These metrics and calculations contribute valuable insights into the reliability and accuracy of the Mobile Weather Station with Drones, paving the way for future research endeavors. Potential areas for further exploration include optimizing drone flight patterns, investigating additional meteorological parameters, and refining the integration of real-time data into meteorological models.

#### 4. Conclusion

In conclusion, our Mobile Weather Station equipped with drone technology emerges as a dependable tool for real-time weather monitoring, supported by robust statistical evidence. A meticulous analysis comparing temperature, humidity, and barometric pressure with traditional meteorological data highlights the station's consistent delivery of accurate and precise information.

The temperature analysis reveals the station's impressive accuracy, with a Mean Percentage Error (MPE) of 2.45%, translating to an accuracy of 97.55%. Similarly, humidity readings align seamlessly with ground-based sources, exhibiting an MPE of 1.82%, indicating an accuracy of 98.18%. The barometric pressure analysis further confirms the reliability of our sensors, boasting an MPE of 2.47%, corresponding to an accuracy of 97.53%, offering detailed insights into pressure changes.

A notable strength of the Mobile Weather Station lies in its ability to capture local variations in temperature and humidity, rendering it invaluable for applications requiring nuanced microclimate insights. The integration of drone technology not only enhances mobility but also furnishes a more comprehensive understanding of environmental dynamics.

Looking ahead, future iterations of this technology could explore additional parameters and improved drone autonomy, further enhancing its capabilities. This research significantly contributes to the burgeoning field of drone-assisted environmental monitoring, with promising applications in agriculture, disaster management, and scientific research. The high level of accuracy demonstrated by our Mobile Weather Station, with mean percentage errors well below 5%, positions it as a versatile solution for obtaining precise and localized weather information. This, coupled with its ability to adapt to diverse terrains, solidifies its potential impact on advancing weather monitoring practices.

#### Acknowledgement

This research was feasible thanks to the support of supervisors and friends. Additionally, the author would like to acknowledge the Faculty of Engineering Technology at UTHM for all their help.

#### References

- [1] Madhun, N. Y., Terzija, V., & Skvortsov, A. (2019). Mobile Sensor Networks for Weather Monitoring: A Comprehensive Review. *Energies*, 12(19), 3790.
- [2] Khan, Z. U., Rakocevic, V., & Atiquzzaman, M. (2015). Unmanned Aerial Vehicle as a Mobile Sensor Node in a Wireless Sensor Network. *IEEE Communications Magazine*, 53(6), 57-63.
- [3] Deb, S., Chowdhury, C., & Dey, N. (2018). Drones as a Boon in IoT and Big Data. *Procedia Computer Science*, 132, 841-848.
- [4] Bell, S., & Glenn, L. (2017). Mobile Sensor Platforms for Climate Science: Assisting an Evolving Airborne Capability. *Earth Science Informatics*, 10(3), 365-376.

- [5] He, H., He, L., & Wu, D. (2019). An Efficient Drones-Assisted Weather Data Collection System. *IEEE Transactions on Industrial Informatics*, 15, 1-1.
- [6] Zhan, Y., & Lin, Y. (2016). Drone-based Sensing Systems for Atmospheric Monitoring. *Computers, Environment and Urban Systems*, 58, 144-153. <https://doi.org/10.1016/j.compenvurbsys.2016.03.004>
- [7] Wang, Y., Qiu, X., Zhang, Y., & Song, W. (2017). Unmanned Aerial Vehicles (UAVs) for Environmental Monitoring: A Review. *Environments*, 4(3), 66. <https://doi.org/10.3390/environments4030066>
- [8] Li, Y., & Liu, Y. (2020). Applications of Drones in Agriculture: A Comprehensive Review. *Applied Sciences*, 10(2), 511. <https://doi.org/10.3390/app10020511>
- [9] Barmponakis, E. N., Kontopoulos, I., & Bassiliades, N. (2018). A Survey of Internet of Things (IoT) Architectures. *Expert Systems with Applications*, 107, 1-22. <https://doi.org/10.1016/j.eswa.2018.05.023>
- [10] Liu, S., Qian, Z., & Li, Y. (2016). An Overview of Mobile Crowdsensing Techniques: A Critical Component for the Future of Internet of Things. *Journal of Computer Science and Technology*, 31(3), 405-426. <https://doi.org/10.1007/s11390-016-1654-0>