

Effect of Spring Buffer on Vehicle Dynamic Performance

Muhammad Khairul Najmi ¹, Syabillah Sulaiman^{1*}, Muhamad Asri

Azizul¹

¹ Department of Engineering Technology, Faculty of Engineering Technology, Universiti Tun Hussein Onn Malaysia, Pagoh Education Hub, 84600, Panchor, Johor, Malaysia.

*Corresponding Author: syabillah@uthm.edu.my

DOI: <https://doi.org/10.30880/peat.2024.05.01.035>

Article Info

Received: 28 December 2023

Accepted: 18 January 2024

Available online: 15 June 2024

Keywords

Spring Buffer, Vehicle dynamic, MATLAB Simulink, Arduino Uno, Ride comfort, GY-61/ADXL335 Acceleration Sensor

Abstract

This study investigates at the impact of spring buffers on vehicle dynamic performance, specifically their role as energy-absorbing components in mechanical systems. The issue statement focuses the differences on impact and efficacy of buffer springs dependent on design characteristics such as stiffness, damping qualities, and preload. Road roughness, a critical factor affecting both driving comfort and safety, has been discovered as a significant component in the vibration of the connected system, further impacting the dynamic response of the vehicle. The study's objectives include a thorough evaluation of the dynamic behaviour of buffer springs, the execution of tests to assess the dynamic impacts of different buffer springs, and a complete analysis of the effect of buffer springs on vehicle dynamic performance. The scope is confined to passenger vehicle, primarily focused on the Perodua Myvi, and analysing just unsprung and sprung motion. The process entails creating a prototype with code and circuits, using Fritzing for offline tests and Arduino with MATLAB Simulink for online experimentation. Acceleration sensors (GY-61/ADXL335) are used, and trials are carried out at speeds of 10 km/h, 15 km/h, and 25 km/h on a standardised bump. The results, obtained through Arduino and MATLAB Simulink analysis, highlight the varying effects of buffer springs on both sprung and unsprung masses under different conditions and speeds, providing valuable insights for optimising buffer spring design and improving overall vehicle comfort, safety, and performance and shows the silicon buffer much better than rubber buffer. The study, which compared rubber and silicon buffers in a Perodua Myvi, found that silicon buffers provided better impact reduction and ride comfort. Accelerometer data analysed using Arduino UNO and MATLAB Simulink revealed a direct proportional relationship between sprung and unsprung motion and vehicle speed.

1. Introduction

The suspension system of automotive is known to absorb vehicle vibration. The suspension two essential components are the spring and the shock absorber. By allowing the vehicle to absorb the vibrations or to lessen their severity, this makes for a comfortable driving experience. The dynamic elements that affect the comfort of

the ride (mechanical comfort is low and extremely low frequency vibration, shocks, and accelerations) and the level of high frequent vibration and noise (vibroacoustic comfort) [1].

Vibration-related problems frequently affect the comfort of driving. Vibration has several causes and effects on driving situations like lower acceleration levels of vibrations may cause fatigue structure of spine [2]. Spring buffers are frequently used in mechanical systems as energy-absorbing parts that reduce the effects of outside forces, reduce vibrations, and preserve system stability. However, depending on design factors including stiffness, damping properties, and preload, spring buffers precise impact and efficacy might vary. One of the most significant elements affecting the vibration of the linked system is road roughness, which not only affects the vehicle's comfort and safety while driving but also exacerbates the dynamic response of the bridge [3]. Therefore, it is necessary to research how spring buffer affects the functionality and behaviour of a vehicle's dynamic performance.

Vehicle dynamics is the study of how motor vehicles move. To establish the relationship between the force operating on the vehicle and the characteristics of their motion, assessed in qualitative and quantitative terms, applied mechanics technique are utilized [4]. The capacity of a vehicle to retain stability, maneuverability and control under diverse driving circumstances is referred to as vehicle dynamic performance. It affected things like the vehicle control system, weight distribution, suspension design, tire properties and aerodynamics.

The term ride comfort refers to the general satisfaction and health of the passenger in vehicle during travel. From the perspective of automotive engineering, the concept of ride comfort broadly refers to any oscillatory phenomenon that affects a vehicle passenger. The study of mechanical and acoustic oscillation in cars and how humans feel these is sometimes referred to as noise, vibration, and harshness (NVH) [5]. The analysis of vehicle ride suggests regulating vibration such that the passenger perception of discomfort doesn't rise over a specific threshold. The natural frequency of human body should be close to 1 Hz for smooth ride. For smooth rides, a suggested root mean square (RMS) of 0 g to 0.04 g, for medium rides, 0.04 g to 0.06 g and above 0.06 g for hardest rides [6].

Sprung mass and unsprung mass are words used in vehicle dynamics to describe the various components of a vehicle's suspension system. The sprung mass is the mass of the vehicle body and other components directly supported by the suspension system, where the unsprung mass is the mass of component not supported by the suspension such as wheel and tires [7]. For a half car model, the degree of freedom often refers to the quality of independent variables that characterise the system motion and the number of degrees of freedom in half car model is normally four. These degrees of freedom are the vertical motion of the car sprung mass, the vertical motion of the unsprung mass, the pitch motion of the sprung mass and the pitch motion of the unsprung mass [8].

In the context of mechanical engineering and building systems, a damper is a device or reduces the motion, oscillation, or vibration of a system. It is intended to disperse or absorb energy and lessen the motion amplitude [9]. Then, Helical compression spring are the basic elastic component of the suspension system. They connect the wheel to the body, store energy, absorb road imperfection shock, and sent the energy to the body. When evaluating the load, helical springs may be divided into three categories which are compression, tension, and torsion. Strain energy is the primary aspect to be taken into consideration while designing spring, which are often comprised of metal [10]. In a spring mass system, a cushioning buffer functions as a damper. Cushioning buffers, specifically for automobile use, increase driving comfort and stability on curves roads and also give superior breaking capabilities [11]. Additionally, the front and rear suspension coil spring are different. One type of suspension pad with high stock absorption is the Urethane buffer [12]. The spring buffer will put between helical spring on the shock absorber.

2. Material and Method

At early stage, literature review will be carried out regarding the vehicle dynamics performance, vehicle model, suspension system including damper, the degree of freedom of the vehicle and the related data acquisition system (DAQ) involve in the vehicle dynamic analyse. This process will lead the next activities whereas the development of offline sensor had been carried out. In this stage, the involvement of coding be tested to the sensor and DAQ to ensure that the integration between sensor and DAQ establish. After development of offline sensor success, the prototype that including the DAQ had been attached to the vehicle part such as at sprung and unsprung mass location.

2.1 Fritzing software

CAD software is typically used by electrical engineers, whereas designer prefer to work more manually. In addition to using an Arduino and other electronic prototyping kits, a breadboard, and manually connecting the circuits. This demonstrates that a copy and paste, trial and error method of self-education is appropriate. It is also makes possible the seeing drawing, seeing cycle in which the design is examined in a limited number of

modifications before being put to the test. For the experiment, the software that been used in this project to draw the circuit is fritzing. In Fig. 1 the circuit have Arduino Uno that connected four ADXL335 sensor for this experiment.

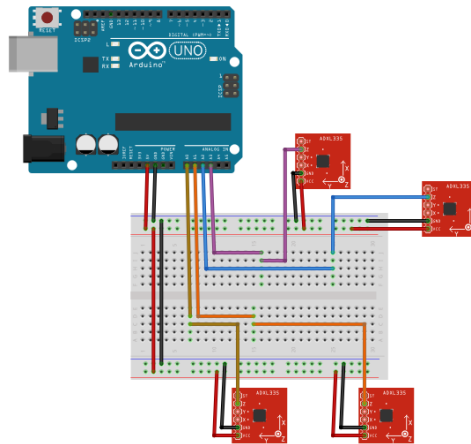

Fig. 1 ADXL335 sensor at sprung mass

2.2 Experiment setup

The decision of the sensor location is based on the literature review. When the attachment of prototype at vehicle part is success, the trial been set up and the comparison trial data with previous study been made. Next, the experiment will be carried out at three speeds based on the previous literature which are 10, 15 & 25 km/h. The collected findings will be analyzed by comparing the effect of vehicle dynamic performance based on different speeds applied.

The sensor had been put at the sprung mass (engine bay and absorber nut) as Fig. 2 and unsprung mass (at the lower arm) as Fig. 3 and the spring buffer had been put in the middle of the spring for rubber buffer and silicon buffer as Fig. 4. The sensor and the spring buffer will be put at the front and rear to get the data.

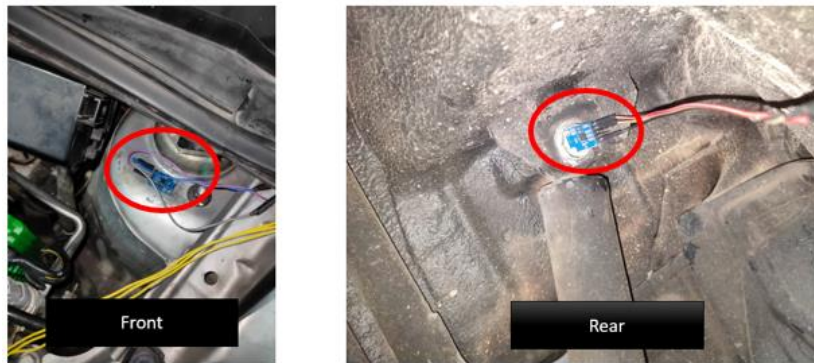

Fig. 2 ADXL335 sensor at sprung mass

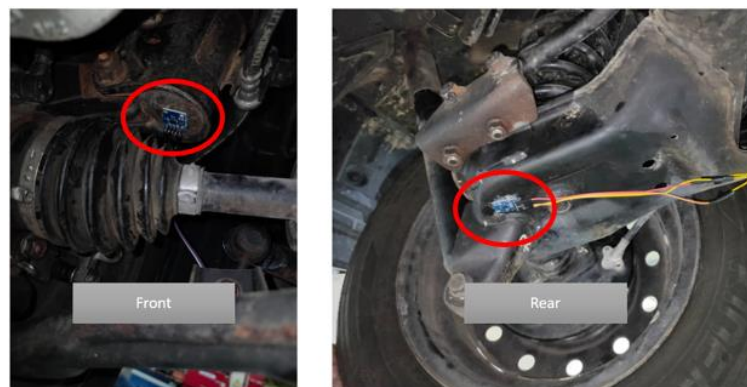

Fig. 3 ADXL335 sensor at unsprung mass



Fig. 4 Spring buffer setup

The Arduino Uno is used in the experiment as an actuator, communicating with MATLAB Simulink to collect data and been test on 2.44 meter \times 0.40 meter \times 0.07 meter (length \times width \times height) based on Fig. 5. The data been collected from vehicle that hit bump as Fig. 6.



Fig. 5 Actual speed bump setup



Fig. 6 Condition vehicle hit bump

3. Result and Discussion

The vertical acceleration measured with an accelerometer indicated that utilizing a buffer is superior to not using one. The graph was created to show the highest point when the vehicle was before, during, and after hitting the bump. Based on the investigation into driving comfort, the vehicle recommended using conventional springs for minimal vibration and comfort when driving. The finding for this research would indicate how the vehicle dynamics performance is impacted by changes in speed, as shown in Fig. 7. The acceleration reading had been used to demonstrate the outcomes, Fig. 8 depicting the vehicle acceleration in three conditions, with rubber buffer, silicon buffer and without buffer.

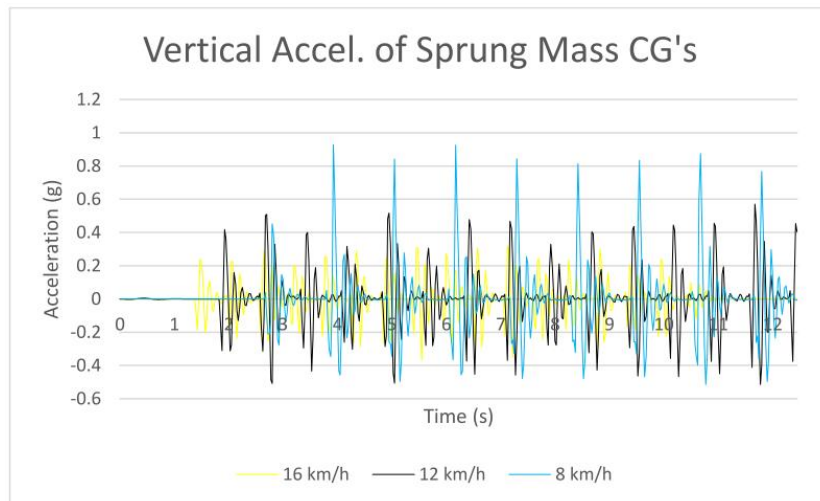

Fig. 7 Simulation result

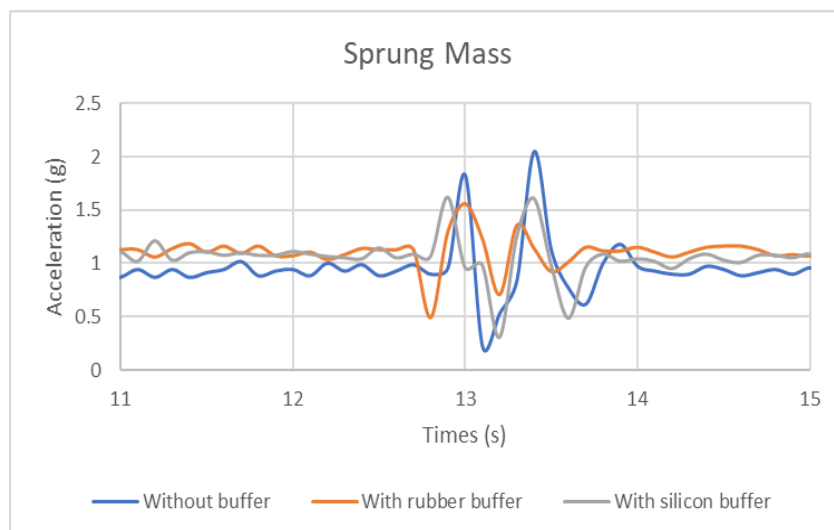
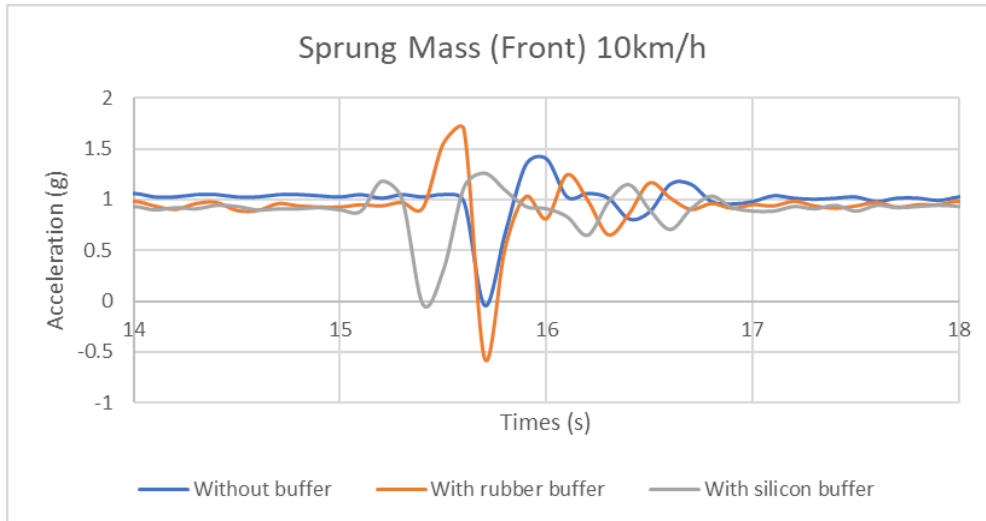

Fig. 8 Experimental Result

3.1 Sprung Acceleration

Experiment with sprung mass acceleration on ride comfort on speed bump that is 2.44 meter × 0.40 meter × 0.07 meter (length × width × height). The outcome is obtained by three parameters which is rubber buffer, silicon buffer and without buffer. The parameter is compared in g force unit which 1g equal to 9.81 m/s². The test is conducted in 10 km/h, 15 km/h, 25 km/h.



(a)

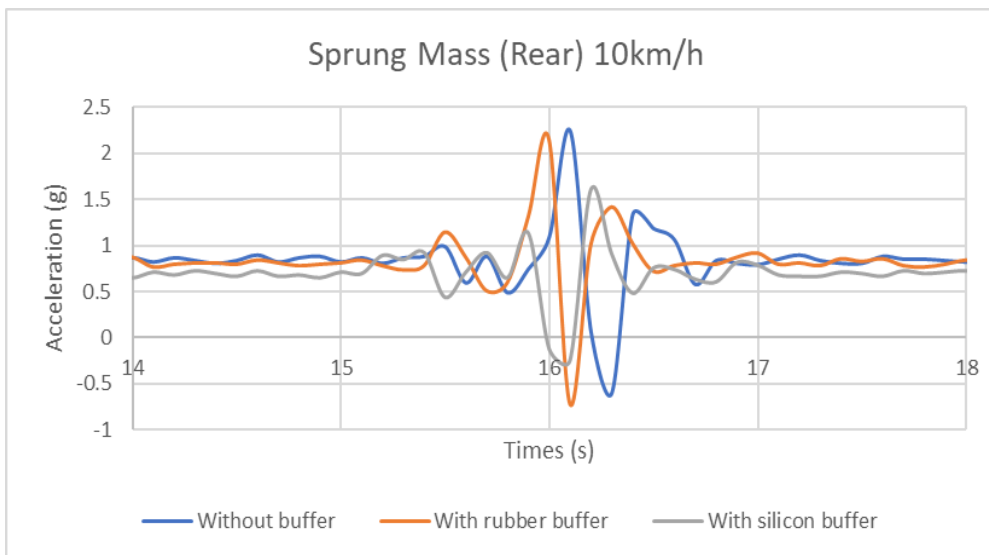

(b)

Fig. 9 Result sprung mass (a) front at 10 km/h; (b) rear at 10 km/h

Fig. 9 shows the result of sprung mass at 10 km/h that been compare which is rubber buffer, silicon buffer and without buffer at the absorber when the vehicle hit bump.

In graphs, there are three critical point shows which are the first point that before hit the bump for absorber without buffer is 1.045 g (front) and is 2.242 g (rear), for rubber buffer is 1.693 g (front) and is 2.151 g (rear), then for silicon buffer is 1.181 g (front) and is 1.136 g (rear). The second point shows the vehicle during impact are -0.045 g (front) and -0.606 g (rear) for the absorber without buffer, rubber buffer are -0.556 g (Front) and -0.712 g (rear) then for silicon buffer is -0.034 g (front) and -0.242 g (rear). The last for critical point that after cleared bump are 1.397 g (front) and 1.333 g (rear) for the absorber without buffer, the rubber buffer is 1.034 g (front) and 1.424 g (rear), then for the silicon buffer is 1.261 g (front) and 1.606 g (rear).

From that, the analysis has been made based on three critical point of the three parameter that shown the silicon buffer absorb more vibration to give the driver and passenger more comfort while drive the vehicle than absorber without buffer and rubber buffer.

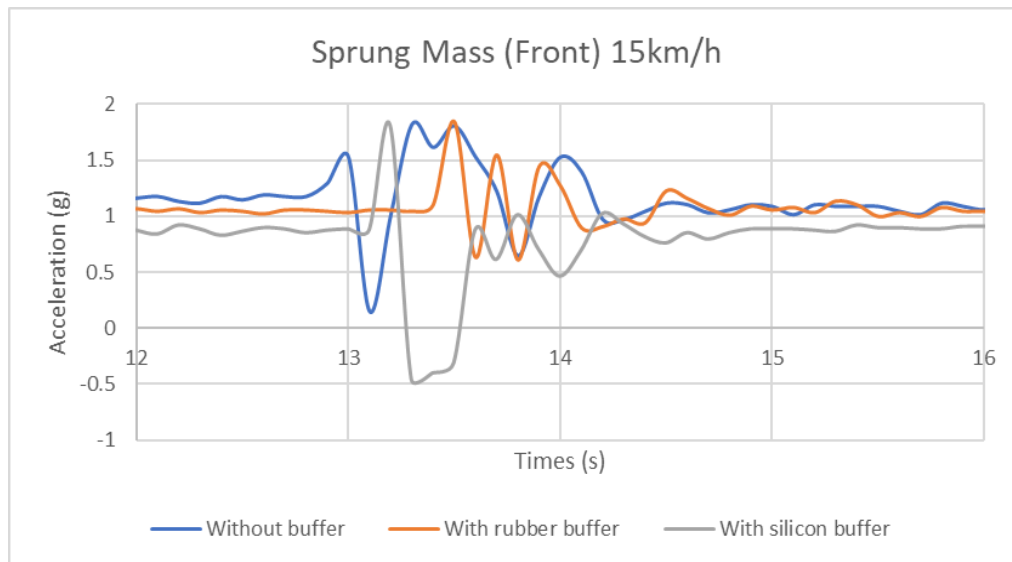

(a)

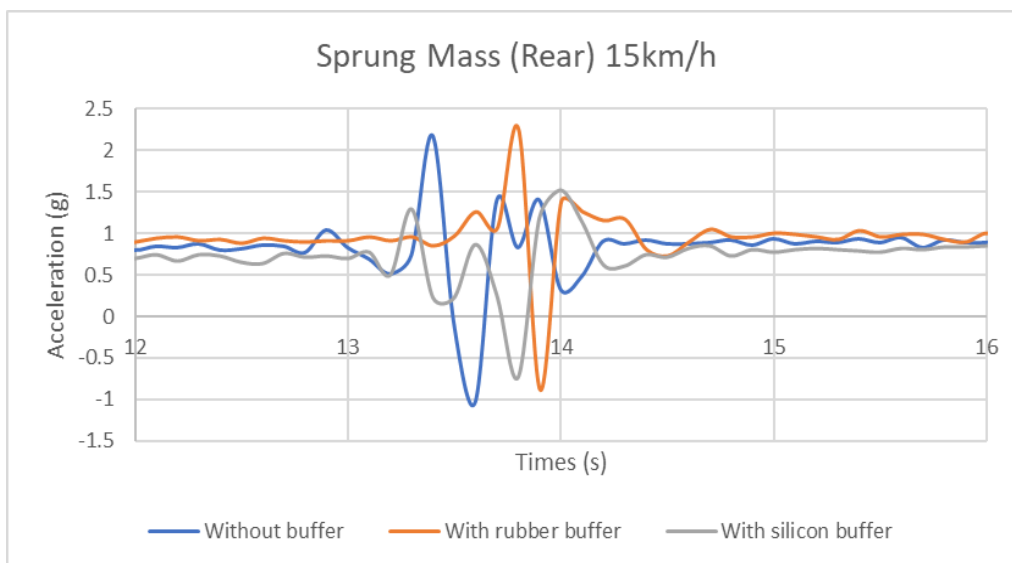

(b)

Fig. 10 Result sprung mass (a) front at 15 km/h; (b) rear at 15 km/h

The data that been gather in Fig. 10 shows the result of absorber without buffer, with rubber buffer and silicon buffer at speed 15 km/h for sprung mass that been compare at the absorber when the vehicle hitting the bump.

In the graph, there are three critical point shows which are the first point that before hit the bump for absorber without buffer is 1.529 g (front) and is 2.181 g (rear), for rubber buffer is 1.840 g (front) and 2.242 g (rear), then for silicon buffer is 1.106 g (front) and 0.863 g (rear). The second point show the absorber during the impact is 0.147 g (front) and -1.030 g (rear) for the vehicle that without buffer, rubber buffer is 0.636 g (Front) and -0.878 g (rear), then for silicon buffer is -0.454 g (front) and -0.727 g(rear) it is cause by the noised from the sensor that the graph gets like that. The last for critical point that after cleared the bump is 1.823 g (front) and 1.393 g (rear) for the absorber without buffer, the rubber buffer is 1.545 g (front) and 1.378 g (rear), then for the silicon buffer is 0.875 g (front) and 1.515 g (rear).

The analysis of the sprung mass at a speed 15 km/h shown the silicon buffer is better compared to absorber without buffer and absorber with rubber buffer by absorbing the vibration of the vehicle give driver and passenger more comfort.

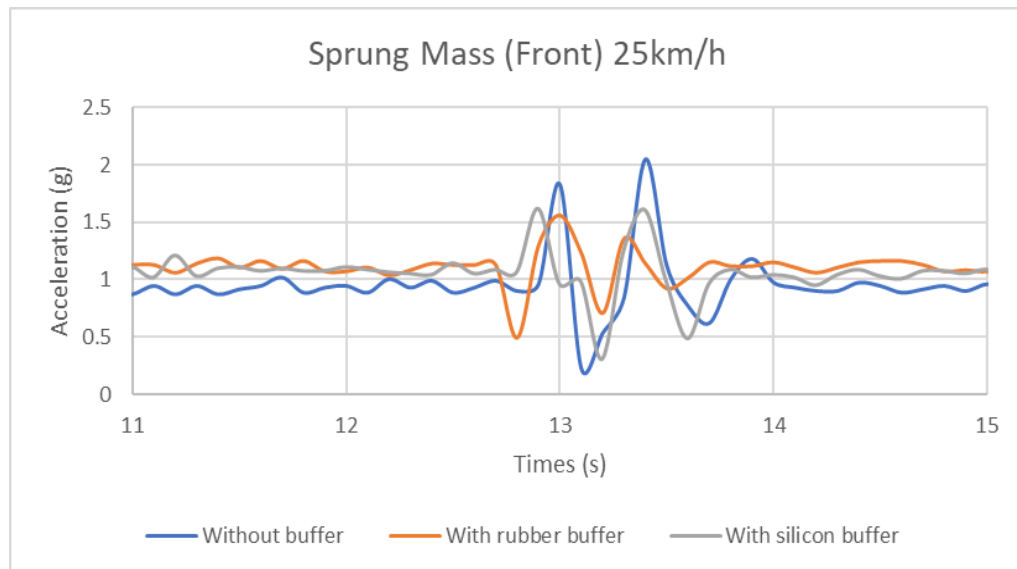

(a)

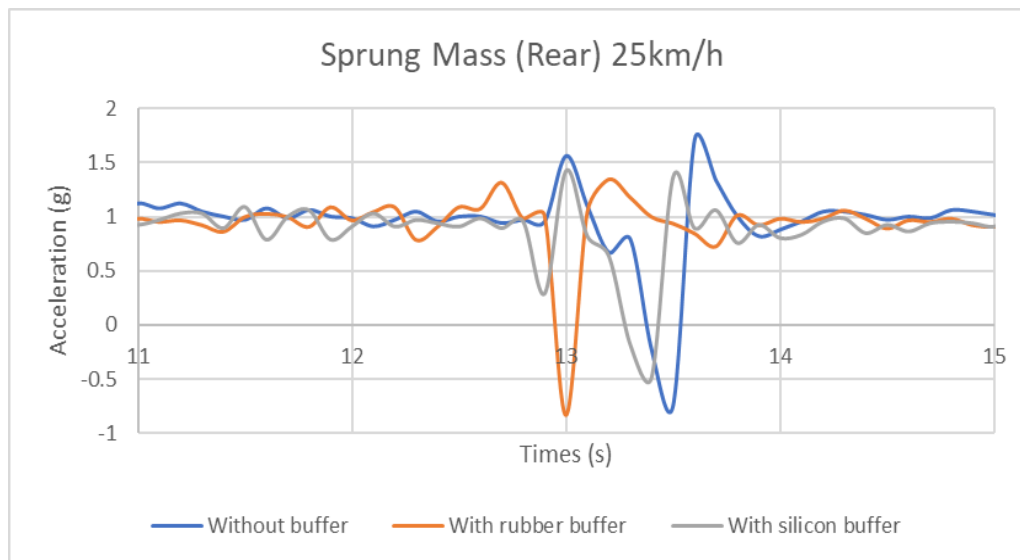

(b)

Fig. 11 Result sprung mass (a) front at 25 km/h; (b) rear at 25 km/h

From Fig. 11 shows the result of vehicle without buffer, with rubber buffer and silicon buffer at speed 25 km/h for sprung mass that been compare at the suspension when the vehicle hit bump.

In the graph, there are three critical point shows which are the first point that before hit the bump for absorber without buffer is 1.823 g (front) and is 1.560 g (rear), for rubber buffer is 1.125 g (front) and is 1.318 g (rear), then for silicon buffer is 1.625 g (front) and is 1.424 g (rear). The second point shown the vehicle during the impact is 0.220 g (front) and -0.742 g (rear) for absorber without buffer, rubber buffer is 0.488 g (Front) and -0.833 g (rear) then for silicon buffer is 0.306 g (front) and -0.484 g (rear). The last for critical point that after cleared the bump is 2.044 g (front) and 1.712 (rear) for absorber without buffer, for rubber buffer is 1.556 g (front) and 1.181 g (rear), then for the silicon buffer is 1.163 g (front) and 1.363 g (rear).

The comparison between three parameters silicon buffer offers much better for ride comfort then absorber without buffer and absorber with rubber buffer due to the g force that produce is low in experimental data that been collect.

3.2 Unsprung Acceleration

In this experiment, the measuring acceleration of unsprung mass was considered due to the measurement that not supported by an absorber when riding on speed bump that have dimension 2.44 meter \times 0.40 meter \times 0.07 meter (length \times width \times height). There are three parameters in this experiment which are rubber buffer, silicon buffer and without buffer.

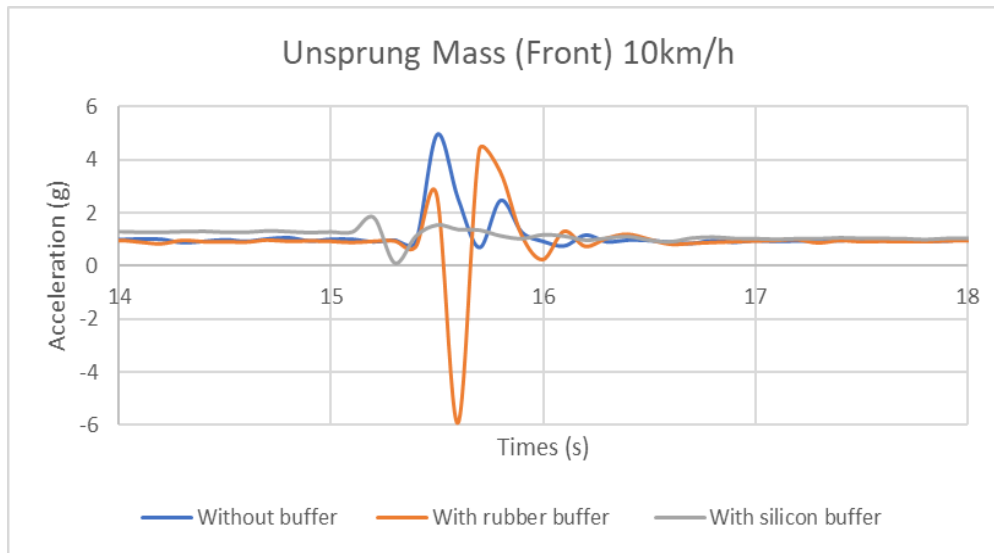

(a)

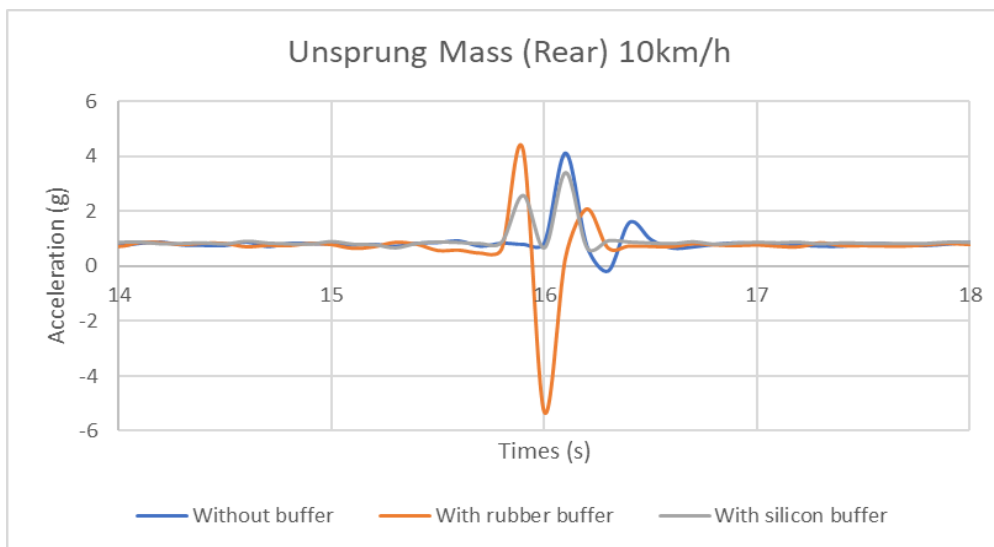

(b)

Fig. 12 Result unsprung mass (a) front at 10 km/h; (b) rear at 10 km/h

The comparison between rubber buffer, silicon buffer, and without buffer when hit bump is shown in Fig. 12 for unsprung mass. The data obtained from that clearer understanding of the peak point between the three conditions of the buffer. In the graph there are three critical points, the first point is the position of the vehicle before hitting the bump. The second point is during the impact and the last point is after clearing the bump.

The result of the absorber without buffer before hitting the bump is 4.937 g (front) and 4.121 g (rear), for the rubber buffer is 2.656 g (front) and 4.283 g (rear) then the silicon buffer is 1.837 g (front) and 2.592 g (rear). The second point during the impact for absorber without buffer is 0.671 g (front) and -0.175 g (rear), for rubber buffer are -5.921 g (front) and -5.297 g (rear) than silicon buffer are 0.093 g (front) and 0.669 g (rear). The third point is after clearing the bump for absorber without buffer are 2.453 g (front) and 1.594 g (rear), for rubber buffer are 4.343 g (front) and 2.094 g (rear) than for silicon buffer are 1.546 g (front) and 3.427 g (rear).

Upon analysis on the absorber at speed 10 km/h for unsprung mass shown the silicon buffer given more comfort for vehicle. This enhancement is due to the discovery that the silicon buffer results in reduced g-forces during the experimental simulation of hitting a speed bump.

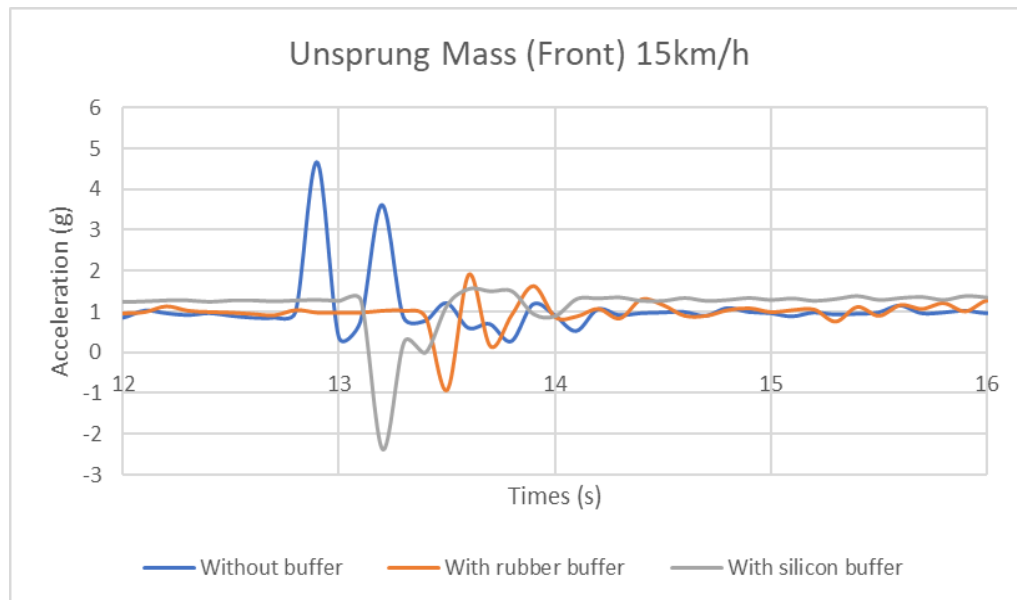

(a)

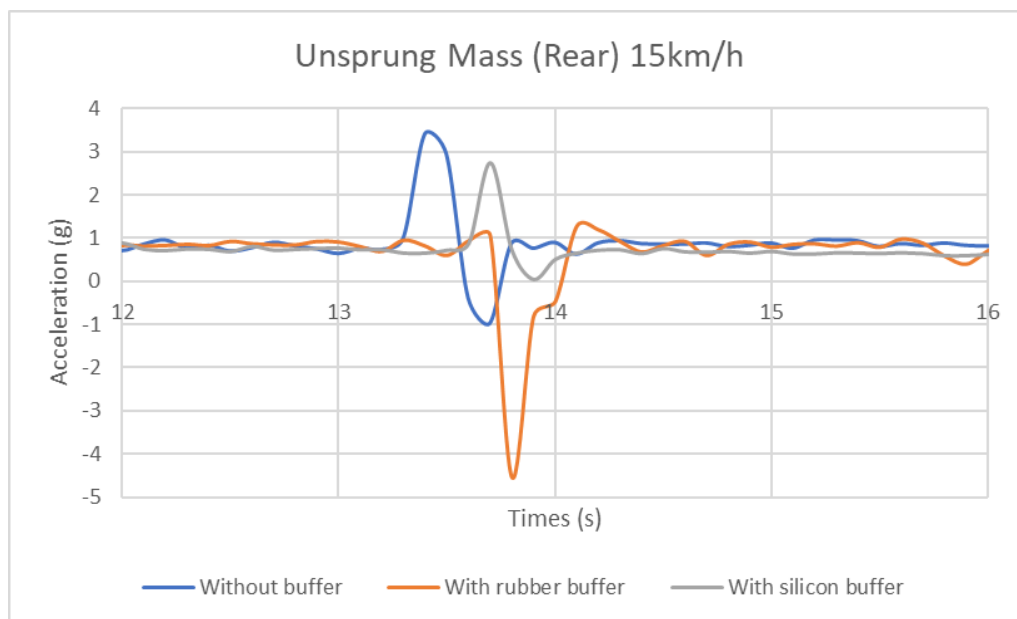

(b)

Fig. 13 Result unsprung mass (a) front at 15 km/h; (b) rear at 15 km/h

The result shown the waveform for unsprung mass in speed 15 km/h as in Fig. 13. There are three critical point and three condition that before the vehicle hitting the bump, during the impact and after cleared the bump for all condition on the absorber.

The data will be gathered from the graph which are for the first point is absorber without buffer before hitting bump are 4.671 g (front) and 3.405 g (rear), for rubber buffer are 1.921 g (front) and 1.067 g (rear), then silicon buffer are 1.267 g (front) and 2.747 g (rear). The second point that during the impact for absorber without buffer are 0.390 g (front) and -0.986 g (rear), for rubber buffer is 0.156 g (front) and -4.540 g (rear) then for silicon buffer is -2.360 g (front) and 0.038 g (rear). The third point after cleared the bump for absorber without buffer are 3.625 g (front) and 0.864 g (rear), for rubber buffer is 1.640 g (front) and 1.283 g (rear) then for silicon buffer is 1.546 g (front) and 0.728 g (rear).

From the data had been gathered, the silicon buffer shown the better result by absorbing the vibration during hitting speed bump in speed 15 km/h then absorber without buffer and absorber with rubber buffer give smoother and more comfortable ride for both driver and the passengers while driving the vehicle.

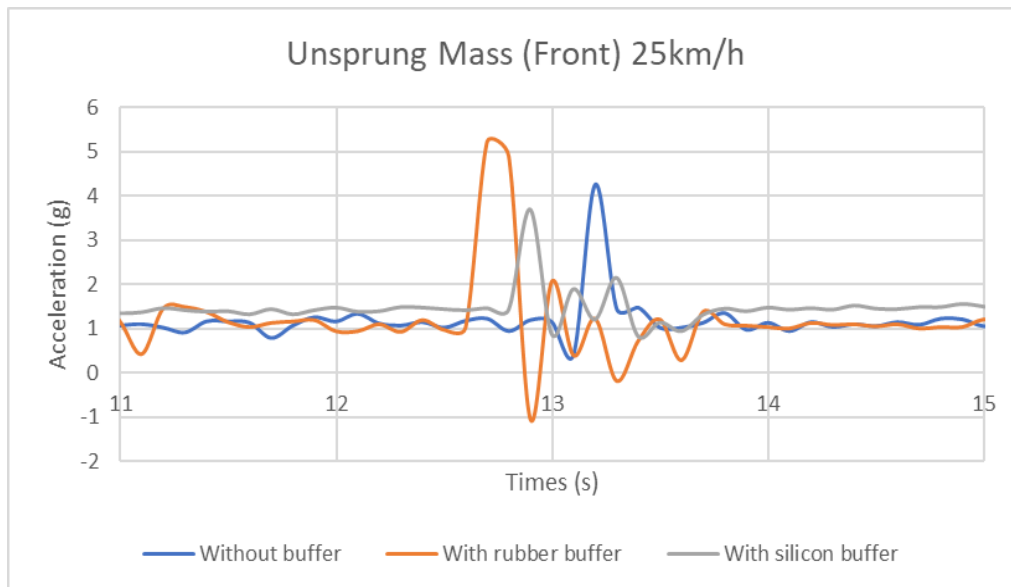

(a)

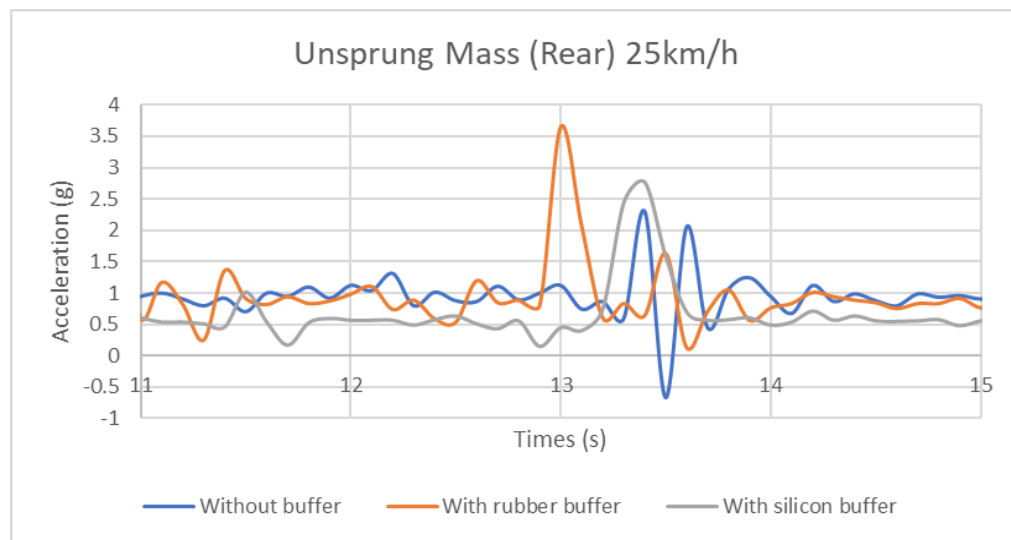

(b)

Fig. 14 Result unsprung mass (a) front at 25 km/h; (b) rear at 25 km/h

The data have been recorded in Fig. 14 for a speed of 25 km/h during the experiment. The graph shows the different in the wave form from the three parameters which are the absorber without buffer, rubber buffer, and silicon buffer. The purpose of the experiment is to see the comfort of the vehicle during hitting a speed bump.

From the graph, there are three critical point that consider which are before hitting bump, during the impart and after cleared the bump. The first point for absorber without buffer is 1.140 g (front) and 2.297 g (rear), for rubber buffer is 4.890 g (front) and 3.648 g (rear), then for silicon buffer is 3.697 g (front) and 0.563 g (rear). The second point for the absorber without buffer is 1.040 g (front) and -0.662 g (rear), for rubber buffer is -1.046 g (front) and 0.608 g (rear) then for silicon buffer is 0.872 g (front) and 0.155 g (rear). The last point for absorber without buffer is 4.250 g (front) and 2.054 g (rear), for rubber buffer get 2.062 g (front) and 1.635 g (rear) then for silicon buffer get 1.895 g (front) and 2.776 g (rear).

The analysis based on three conditions of the absorber shown the silicon buffer can absorb more vibration due to the vehicle that hitting the speed bump and can give comfort while driving the vehicle compared to the absorber without buffer and absorber with rubber buffer.

3.3 Root Mean Square (RMS) of Vehicle ride test

The root mean square (RMS) can be used to calculate average value of a set of integers. It is typically used to describe the magnitude or intensity or a quality. To measure the RMS, each value must be squared. The mean (average) is then calculated. The RMS provides a method for depicting the overall “effective” or “typical” value of a dataset by using both positive and negative value. It is frequently used in mathematics, physics, engineering, and statistics to analyse and compare data.

Table 1 RMS of Vehicle Ride Motion (Front)

Type	Without buffer			Rubber buffer			Silicon buffer		
Speed	10 km/h	15 km/h	25 km/h	10 km/h	15 km/h	25 km/h	10 km/h	15 km/h	25 km/h
Sprung	1.047 g	1.358 g	0.821 g	0.921 g	1.133 g	1.253 g	0.845 g	0.763 g	1.160 g
Unsprung	1.056 g	1.027 g	1.317 g	1.195 g	1.033 g	1.548 g	1.543 g	1.595 g	2.078 g

Table 2 RMS of Vehicle Ride Motion (Rear)

Type	Without buffer			Rubber buffer			Silicon buffer		
Speed	10 km/h	15 km/h	25 km/h	10 km/h	15 km/h	25 km/h	10 km/h	15 km/h	25 km/h
Sprung	0.728 g	0.725 g	1.266 g	0.708 g	0.874 g	0.973 g	0.502 g	0.528 g	0.869 g
Unsprung	0.752 g	0.774 g	0.985 g	0.885 g	0.877 g	1.019 g	0.804 g	0.597 g	0.393 g

The table presents the root mean square (RMS) value for vehicle ride motion while hitting a bump obstacle based on the data provided in Table 1 and Table 2. The data discusses the subtle dynamics, demonstrating how the buffer and speed selection affects the acceleration profiles in both the sprung and unsprung states. In addition, the table demonstrates a significant decrease in acceleration after overcoming the bump obstacle for silicon buffer then absorber without buffer and rubber buffer. From that evident, the vertical acceleration of the vehicle with silicon buffer has potential to positively impact to the vehicle ride comfort.

4. Conclusion

In conclusion, the dynamic behaviour of buffer springs which are important components in mechanical systems for energy absorption and vibration reduction, was thoroughly investigated. The tests, conducted on a Perodua Myvi and analysing both sprung and unsprung motion at speeds of 10 km/h, 15 km/h, and 25 km/h, indicated significant differences between rubber and silicon buffers.

Then, the analysis of the impact on the sprung mass, both rubber and silicon buffers revealed their usefulness in lowering acceleration during the first impact and affecting the following rebound after hitting a bump. The silicon buffer consistently displayed reduced acceleration values, showing its potential for improving ride comfort. Furthermore, for the unsprung mass, both buffer types efficiently reduced acceleration during impact, with the silicon buffer consistently outperforming the rubber buffer across different speeds.

The data collected by the accelerometers using Arduino UNO and MATLAB Simulink, then converted the data into Microsoft Excel in order to create a graph for sensor. The data from the sensor show that relation between sprung, unsprung and vehicle speed is directly proportional.

Acknowledgement

The author would like to thank the Faculty of Engineering Technology, Universiti Tun Hussein Onn Malaysia for providing the necessary facility during this study.

References

- [1] D. Dacova, "Ride comfort in road vehicles: a literature review," 2021.
- [2] R. A. Bonney and E. N. Corlett, "Vibration and spinal lengthening in simulated vehicle driving," 2003.
- [3] G.-Q. Zhang, B. Wang, Q. Zhu, and Y.-L. Xu, "Dynamic behavior and ride comfort of a vehicle moving on a long suspension bridge within multi-mode lock-in regions," *Journal of Wind Engineering and Industrial Aerodynamics*, vol. 234, p. 105345, Mar. 2023, doi: 10.1016/j.jweia.2023.105345.
- [4] O. V. Oțăt, I. Dumitru, L. Racilă, D. Tutunea, and L. Matei, "Analysis on the Dynamic Performance of Vehicles," *Advanced Engineering Forum*, vol. 42, pp. 71–78, Sep. 2021, doi: 10.4028/www.scientific.net/aef.42.71.
- [5] B. Heiřing and M. Ersoy, "Ride Comfort and NVH," in *Chassis Handbook*, Vieweg+Teubner, 2011, pp. 421–448. doi: 10.1007/978-3-8348-9789-3_5.
- [6] S. Hegazy and C. Sandu, "Vehicle Ride Comfort and Stability Performance Evaluation," 2018, [Online]. Available: <http://www.sae.org>
- [7] Rajesh Rajamani, *Vehicle Dynamics and Control*, Frederick F. Ling. New York: Springer-Verlag, 2006. doi: 10.1007/0-387-28823-6.
- [8] [8] T. D. Gillespie, *Fundamentals of Vehicle Dynamics*. Warrendale, PA: SAE International, 1992. doi: 10.4271/R-114.
- [9] "Fundamentals of Mechanical Vibration - S Graham Kelly," 1999.
- [10] A. Jain, S. Misra, A. Jindal, and P. Lakhian, "Structural analysis of compression helical spring used in suspension system," 2017, p. 020080. doi: 10.1063/1.4990233.
- [11] T. A. Jadhav, M. P. Angaj, and V. N. Kapatkar, "Finite Element Analysis of Helical Coil Spring with Cushioning Buffer," 2019. [Online]. Available: www.ijert.org
- [12] S. S. Patil and Prof. Dr. K. H. Inamdar, "A Review on Vehicle Suspension with Urethane Buffer," *Int J Res Appl Sci Eng Technol*, vol. 11, no. 1, pp. 424–426, Jan. 2023, doi: 10.22214/ijraset.2023.48584.