

# Three Phase Power Supply for Induction Motor and Power Factor Correction Trainer

Abdul Hafiz Loh Bojeng<sup>1</sup>, Rasida Norjali<sup>1\*</sup>, Mohamad Syah Rizal Abdullah<sup>1</sup>

<sup>1</sup> Faculty of Engineering Technology, University Tun Hussein Onn Malaysia,  
86400 Pagoh, Johor, Malaysia

\*Corresponding Author: [rasida@uthm.edu.my](mailto:rasida@uthm.edu.my)

DOI: <https://doi.org/10.30880/peat.2024.05.02.006>

## Article Info

Received: 26 June 2024

Accepted: 10 July 2024

Available online: 25 November 2024

## Keywords

Three Phase, Power Supply, Single Phase, stability, dependability, efficiency

## Abstract

Three phase power supply is commonly used in high total load demand because the ability to supply ever-higher power densities is particularly important to experience ever-higher densities. This power supply can help to generate power to high voltage equipment such as induction motor and power factor correction trainer. The lack of a three-phase power supply at Makmal Peralatan dan Pengujian at UTHM Pagoh will affect the quality and scope of teaching and research activities conducted in these labs. This project aims are to provide the three-phase power supply at Makmal Peralatan dan Pengujian at UTHM Pagoh and adding on some safety future and to improve hands on experiences for students in laboratory. This Three-Phase Power Supply Optimization Project aims to enhance the efficiency, stability, and reliability of three-phase power distribution systems. The objective of the Three-Phase Power Supply Project is to produce 230V for single phase and 415V for three phases and to evaluate the performance of three-phase power distribution systems' stability, dependability, and efficiency. Industrial and commercial electrical networks require three-phase power because it offers a more stable and balanced power supply than single-phase systems. The main goal of this project is to give facility to this laboratory with some safety future which can remotely trip and real time monitoring for three-phase power systems.

## 1. Introduction

A three-phase generator produces three voltages with the same frequency and magnitude, separated by 120 degrees electrically. Three-phase generators produce alternating-current electrical energy, which is then transmitted through three-phase circuits and wiring. A three-phase circuit consists of three single-phase circuits connected by three or four wires. Two wires are required to separate each generated phase or wave. Single waves can supply power to single-phase motors and loads from a three-phase circuit. Three phase circuits are preferred over single-phase circuits in industrial settings [1].

Based on a survey conducted at Makmal Peralatan dan Pengujian at UTHM Pagoh, this lab is experiencing issues due to an insufficient number of three-phase power supplies. This restriction can substantially affect the quality and scope of teaching and research activities conducted in these labs. The absence of three-phase power leads to a range of issues. The primary issue is the limitations of experiments because there will be many advanced experiments and practical classes will be done in this lab that will require three-phase motors, transformers, power factor trainer and other equipment that cannot be conducted without a three-phase power

supply. This will impact on reducing the hands-on learning opportunities for students. The second issue is impact on educational which students will be distracted from understanding and preparedness for real-world applications because of there is absence of three phase supply that cannot provide a complete and realistic learning experience. This will be a disadvantage for students for their future careers. Consequently, the quality of education suffers, lowering students' confidence and competence in dealing with real-world scenarios.

The aim of this project is to develop a Three Phase Power Supply for High Voltage Equipment at Makmal Peralatan dan Pengujian at UTHM Pagoh. The objectives include designing a three-phase power supply for the laboratory, constructing it to facilitate advanced research projects requiring three-phase power, and verifying its performance with induction motors and trainers. The project will generate a three-phase power supply with an output voltage of 415V for three-phase and 230V for single-phase, incorporating a power meter for monitoring. It involves designing and implementing a three-phase power supply system with a 40A molded case circuit breaker (MCCB), Miniature Circuit Breaker (MCB), 40A Earth Leakage Circuit Breaker (ELCB), and a Digital Power Meter to ensure continuous and reliable power distribution within the Electrical Power Lab. Additionally, the project includes developing systems for regular assessment and improvement to meet evolving educational requirements.

Several related past projects have been conducted based on similar systems but with different applications. The first project is titled "Design, Simulation, and Construction of an Automatic Three-Phase Power Selector System." This project involved creating and constructing a fully autonomous system that ensures a continuous and reliable electrical supply for critical infrastructure. [2] Another project, "Optimization Design of a Three-Phase Balanced Power Supply for Vehicle Mobile Power," investigated the impact of unbalanced power on vehicle mobile power supplies, which could potentially cause injury. [3] Additionally, "Modeling of a High Voltage Three-Phase Power Supply Using a Five-Limb Magnetic Shunt Transformer" focused on modeling a high voltage magnetic shunt transformer. [4] Moreover, the project "Design of a Three-Phase Class E Power Amplifier Based on a Wireless Power Transmission System" aimed to increase output power and efficiency, particularly for wireless charging applications. [5] Lastly, the project "Design of a Three-Phase Three-Switch PWM Current Source Rectifier/Inverter of Induction Heating Power Supply for Forging Applications" concentrated on generating electric energy by heating metal bodies with electromagnetic induction and efficiently converting this heat energy. [6]

## 1.1 Electrical Power Systems

Benjamin Franklin was known for the discovery of electricity. Born in 1706 and started investigating electricity in the early 1750s. Particularly the research of kite experiment, confirmed the nature of electricity. The awareness of lightning is extremely powerful and dangerous. The famous 1752 kite experiment consisted of a pointed metal piece on top of the kite and a metal key at the base end of the kite thread. The string passed through the connected key to a Ley den jar.

Electric power systems deliver energy in real time. Real-time power generation, transportation, and supply occur now that the light switch is turned on. Electric power systems are different from water and gas storage systems. Generators produce energy based on demand. Figure 2.1 shows the basic parts of an electric power system. The system begins with the generation of electrical energy in the power plant, which is then converted to high-voltage electricity in the power station for efficient long-distance transportation. Power plants convert various forms of energy into electricity. Electrical energy is generated using multiple energy sources, including heat, mechanical, hydraulic, chemical, solar, wind, geothermal, and nuclear. High-voltage (HV) power lines in the transmission zone of the electric power system transfer energy efficiently across long distances to consumption locations. Substations convert high-voltage electricity into lower-voltage energy, then distributed via power lines to residential, commercial, and industrial consumption [7]. Basic electrical theory revolves around two fundamental elements:

- Voltage
- Current

Voltage, often referred to as electrical potential difference, is the force that pushes electric charges through a conductor. It is measured in volts (V) and represents the energy per unit charge available to move electrons from one point to another within a circuit [8]. Current, on the other hand, is the flow of electric charge through a conductor, typically measured in amperes (A). It indicates the rate at which the charge flows and is essential for the functioning of electrical devices [9].

## 1.2 Electrical Phase

A phase is determined by the electric load distribution that corresponds to the type of unit, which may be a single-phase or three-phase electrical system. Single-phase has less power and requires only two wires, but three-phase requires three or four wires. There are two type of phases that is commonly used:

- Single-Phase

- Three-Phase

This AC sine wave is equivalent to single phase power as the sine wave's highest point on the waveform is known as the peak, or  $V_{peak}$ . There is a dashed line below. This is the  $V_{rms}$  ( $rms = \text{Root Mean Squared}$ ). In this case, the voltage between the hot and neutral wire is  $120V_{rms}$ . This is the voltage used in normal 120V outlets in the household. The equipment ground sign is connected to the neutral wire. In normal circuit operations, a neutral wire carries current but is grounded. In a control panel or residential application, a neutral wire is distinguished by the white insulation [10].

A three-phase power waveform consists of three single phase waveforms with a 120-degree phase shift with three phases. The following single-phase sine wave begins 120 degrees after the previous one ends. After 120 degrees, the next sine wave begins. Three phases are more potent than one phase. This clarifies the reason why most industrial motors are three-phase. Three phase motors are smaller compared to single phase motors with the same horsepower [11]. A synchronous generator generates voltages for a three-phase power system. In a balanced system, the three instantaneous voltages have identical amplitudes but differ by a phase angle of 120.

## 2. Methodology

The methodology and processes involved in project development, focusing on a logical sequence to accomplish objectives. Starting with requirement gathering and practical studies, covers both hardware and software development. Hardware development includes designing and implementing physical components and software development involves creating wiring circuits, schematic diagram and project design modules. According to block diagram below, the three-phase power supply system features several safety features, which provide many advantages, especially in terms of protecting the incoming supply before it reaches the intended load. The system ensures the power supply's integrity and stability by placing a series of protective components along the current flow path from the source to the load.

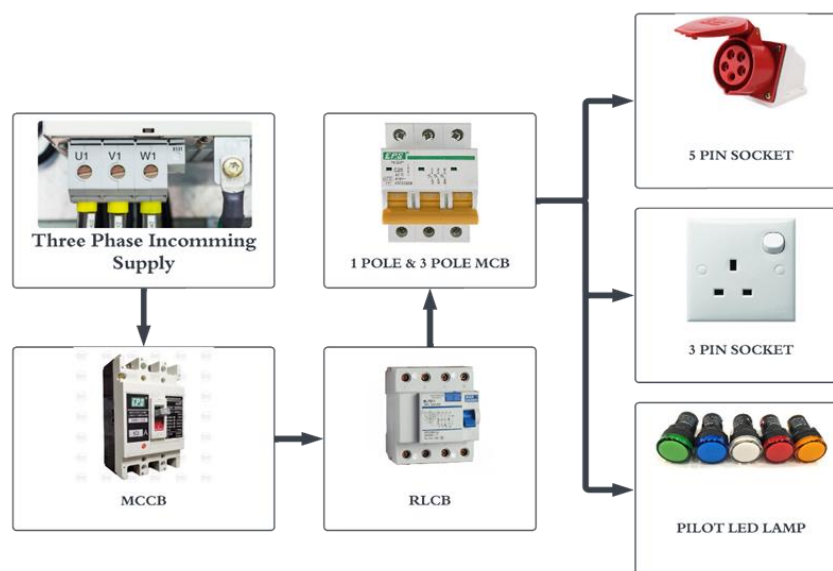

**Fig. 1** Block Diagram

### 2.1 Schematic wiring Circuit

Before beginning any wiring work, it is essential to plan the layout by creating a schematic wiring diagram. This diagram serves as a blueprint, helping to coordinate the placement of all wiring and components. Figure 2 shows a schematic diagram for a three-phase power supply. The process begins with the incoming supply passing through the Molded Case Circuit Breaker (MCCB), which ensures stability by allowing the supply to flow only at safe levels. If the supply is unstable, the MCCB cuts it off to protect the system. The supply then flows through a selector switch, which must be enabled to continue the flow if the MCCB is on. Power then passes through a current transformer, which measures the current for the digital power meter, displaying values for each phase and neutral. After the current transformer, the supply reaches the Earth Leakage Circuit Breaker (ELCB), which shuts down the supply in case of electrical faults to prevent shocks and short circuits. The supply then flows to Miniature Circuit Breakers (MCBs) that provide the final protection and adjust the current to meet the load requirements: reducing 40A to 20A for a 5-pin socket, 16A for a 3-pin socket, and 6A for the digital power meter

and LED pilot lamp. The MCCB’s shunt trip feature allows for remote shutdown via an emergency button, ensuring quick and safe power disconnection in case of hazards.

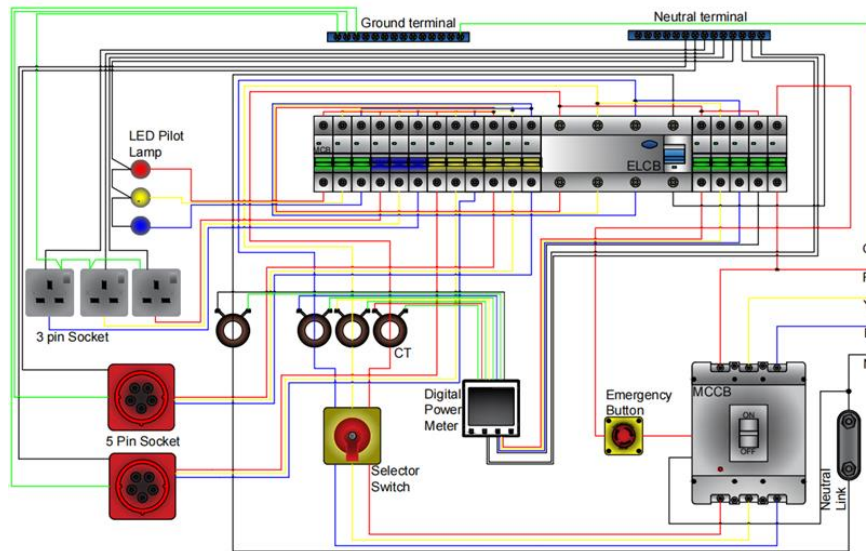

Fig. 2 Schematic Diagram

## 2.2 Hardware Components

Hardware components are the actual physical aspects of a system or device that coordinate to perform specified operations. These components shown below are important for system performance and are used in many different types of categories including technology, electronics, and manufacturing. Safety components are the most important of the many hardware components. These safety components are designed to protect both the system and its users, ensuring that operations are conducted safely and effectively.

- 40A Molded Case Circuit Breaker (MCCB)
  - 40A Earth Leakage Circuit Breaker (ELCB)
  - 20A 3-Pole Miniature Circuit Breaker (MCB)
  - 16A 1-Pole Miniature Circuit Breaker (MCB)
  - 6A 1-Pole Miniature Circuit Breaker (MCB)
  - Current Transformer
  - Digital Power Meter
  - PVC Insulated Cable

## 3. Result and Analysis

The result of three phase power supply for induction motor and power factor correction trainer is taken from two different methods. The first result is taken by using Multimeter which is used to measure the value of Voltage. Second is by taking the reading value from the monitoring system installed on this project that is Digital Power Meter. This both results are compared with theory value. The table below shows the result value.

Table 1 Voltage for every phase

Phases	Multimeter(V)	Digital Power Meter(V)	Theory(V)
Red	240.5	234.8	230
Yellow	240.5	241.8	230
Blue	235.0	240.3	230

Table 2 Line to Line Voltage

Phases	Multimeter(V)	Theory(V)
Red - Yellow	412.0	415
Red - Blue	414.4	415
Yellow - Blue	416.8	415

The results obtained, as shown above, differ slightly from the theoretical values due to various influencing factors. Environmental conditions, such as temperature and humidity, can affect the performance and accuracy of electrical components, leading to deviations. Additionally, connection factors, including the quality of the wiring, the tightness of the connections, and potential resistance at contact points, can contribute to differences. These factors can affect in the measurements, resulting in a slight difference between the experimental results and the theoretical predictions. Such factors are common in practical scenarios and highlight the importance of considering real-world conditions when analyzing and interpreting data.

### 3.1 Hardware Design

The prototype design was constructed in AutoCAD software and acted as a preliminary draft before proceeding on to the actual hardware implementation. Below shows the prototype Design and Real Prototype. This procedure is to provides for exact component placement and detailed planning of wiring routes. This step is important for illustrating the entire layout, ensuring that all components are ideally placed and that the wiring is efficient and effective. By creating the design in AutoCAD, potential problems can be detected and addressed early in the planning process, lowering the risk of mistakes and errors during physical assembly. This precise planning approach is important for producing a well-organized and functioning prototype, which will ultimately improve the reliability and performance of the final product.

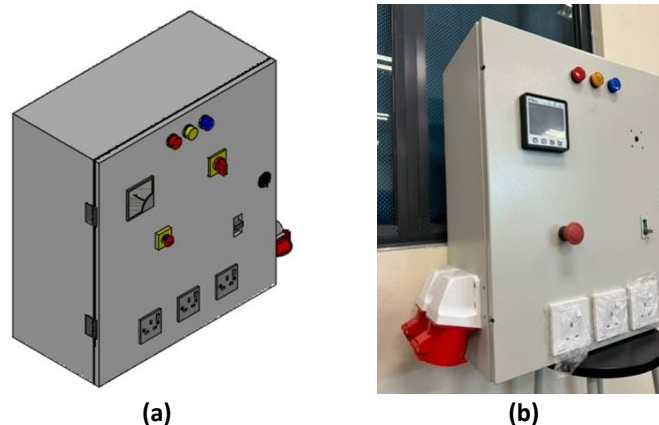

**Fig. 3** Prototype Design (a) Software Design; (b) Actual Design

### 3.2 Testing with Induction Motor and Power Factor Correction Trainer

The three-phase power supply was tested to make sure it can power a power factor correction trainer. This trainer, which is intended to improve the power factor of electrical systems, was connected to the power supply to test its performance. During the testing, the power factor correction trainer was successfully powered by the three-phase supply and ran smoothly throughout. The trainer's successful operation indicates that the three-phase power supply is running properly and can provide stable and enough power. This test not only checks the power supply's performance, but it also certifies the power factor correction trainer's compatibility and reliability when using this power source. Figure 4 below shows the process of testing.



**Fig. 4** Testing with Power Factor Correction Trainer

This test aims to evaluate the efficiency of a three-phase power supply in powering an induction motor that is connected to and controlled by a star-delta circuit. The aim is to determine whether the power supply can consistently provide the required voltage and current to the induction motor throughout operation. During the test, the induction motor was connected to a three-phase power supply using a star-delta circuit, which is typically employed to reduce beginning current and assure smooth performance. By observing the motor's performance under these conditions, the test verifies that the power supply can manage the demands of starting and running the motor without failure. The power meter displays the current, wattage and apparent power values when connected to an induction motor in delta condition as the load.

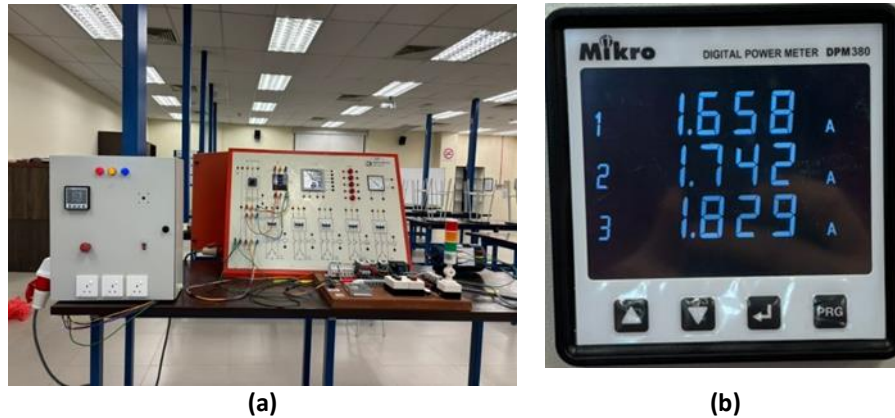

**Fig. 5** Star-Delta Connection Induction Motor (a) Induction motor Testing; (b) Current for Load

### 3.3 Comparison Value for Multimeter measurement and Digital Power Meter

Table 3 and 4 below show the result of error between the value of using Multimeter and the value display by Digital Power Meter and theory value. This comparison highlights the differences between practical measurements and expected theoretical values. The multimeter values represent direct measurements taken from the circuit, while the digital power meter values are obtained from the integrated measurement system within the power supply setup. The theoretical values are calculated based on ideal conditions and assumptions made during the design phase.

**Table 3** Voltage comparison and Multimeter error

Phases	Multimeter(V)	Theory(V)	Multimeter error (%)
Red	240.5	230	4.57
Yellow	240.5	230	4.57
Blue	235.0	230	2.17

**Table 4** Voltage comparison and Digital Power Meter error

Phases	Digital Power Meter(V)	Theory(V)	Digital power meter error (%)
Red	234.8	230	2.09
Yellow	241.8	230	5.13
Blue	240.3	230	4.48

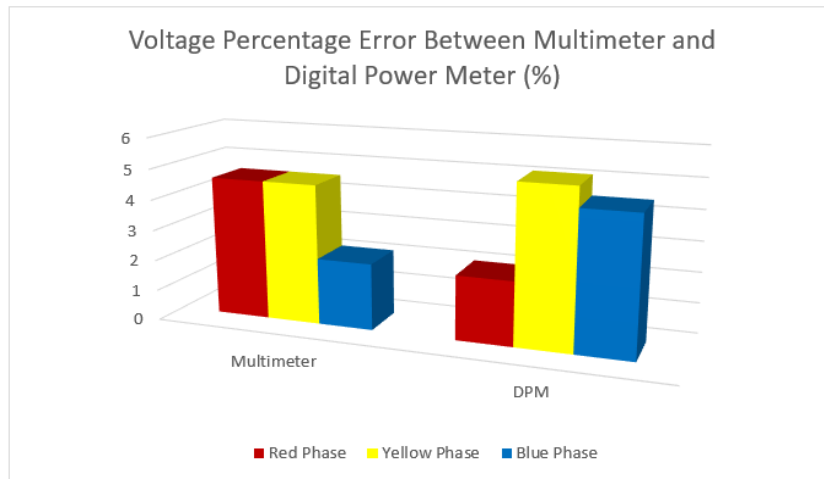

**Fig. 6** Voltage percentage error between Multimeter and Digital Power Meter

As shown in Figure 6, there is a slight difference between the readings produced from the multimeter and the digital power meter. The difference, while reasonable, demonstrates the normal differences that can occur between measurement tools. Such variations might result from a variety of variables, including variances in calibration, precision, and the specific procedures used by each device. Furthermore, environmental factors and the inherent tolerances of the components under test can contribute to this difference. Understanding and accounting for these factors is important when interpreting measurement data to obtain accurate and trustworthy results in practical applications.

#### 4. Conclusion

In conclusion, the project on the "Three-Phase Power Supply for Induction Motor and Power Factor Correction Trainer" has successfully demonstrated its practicality and potential in improving electrical system performance. The project extensively evaluated and analyzed the power supply's reliability and efficiency in powering multiple loads, including induction motors and power factor correction trainers. The findings highlight the importance of proper wiring, insulation, and voltage regulation for safe and efficient operation. Furthermore, the digital power meter's real-time monitoring capabilities provided helpful information into power consumption and helped in energy management. Overall, the project is an important step forward in improving electrical system reliability and energy efficiency, with great opportunities for future developments and implementations for Makmal Peralatan dan Pengujian at UTHM Pagoh.

#### Acknowledgement

Praise and very grateful to ALLAH S.W. T, I managed to complete this project successfully. I would like to express my deepest appreciation to my supervisor Puan Rasida Binti Norjali for her support, guidance, sharing opinions and unfailing patience throughout the project period. I must also thank to lab assistant Encik Shah who helped along with this project to success. I have learned a lot under their guidance. I am also grateful to have supportive parents and friends who helped me and gave their support for me to complete this project. Finally, thanks again to all those who got involved in achieving this project whether directly or indirectly.

#### Conflict of Interest

Authors declare that there is no conflict of interests regarding the publication of the paper.

#### Author Contribution

*The authors confirm contribution to the paper as follows: **study conception and design:** Abdul Hafiz Loh Bojeng<sup>1</sup>, Rasida Norjali<sup>2\*</sup>, Mohamad Syah Rizal Abdullah<sup>3</sup>; **data collection:** Abdul Hafiz Loh Bojeng<sup>1</sup>; **analysis and interpretation of results:** Abdul Hafiz Loh Bojeng<sup>1</sup>, Rasida Norjali<sup>2\*</sup>, Mohamad Syah Rizal Abdullah<sup>3</sup>; **draft manuscript preparation:** Abdul Hafiz Loh Bojeng<sup>1</sup>, Rasida Norjali<sup>2\*</sup>. All authors reviewed the results and approved the final version of the manuscript.*

## References

- [1] Abur, A., Singh, H., Liu, H., & Klingensmith, W. N. (2002). Three Phase Power Flow for Distribution Systems with Dispersed Generation. ResearchGate. [https://www.researchgate.net/publication/238597281\\_Three\\_Phase\\_Power\\_Flow\\_for\\_Distribution\\_Systems\\_with\\_Dispersed\\_Generation](https://www.researchgate.net/publication/238597281_Three_Phase_Power_Flow_for_Distribution_Systems_with_Dispersed_Generation)
- [2] Awunde, P., & Ashigwuike, E. C. (2021). DESIGN, SIMULATION AND CONSTRUCTION OF AUTOMATIC THREE-PHASE POWER SELECTOR SYSTEM. ResearchGate. [https://www.researchgate.net/publication/355702310\\_DESIGN\\_SIMULATION\\_AND\\_CONSTRUCTION\\_OF\\_AUTOMATIC\\_THREE-PHASE\\_POWER\\_SELECTOR\\_SYSTEM](https://www.researchgate.net/publication/355702310_DESIGN_SIMULATION_AND_CONSTRUCTION_OF_AUTOMATIC_THREE-PHASE_POWER_SELECTOR_SYSTEM)
- [3] W. Zhang, H. Li, J. Bao, X. Pan, Z. Wang and P. Liu, "Optimization Design of Three-Phase Balanced Power Supply for Vehicle Mobile Power," 2022 2nd International Conference on Computational Modeling, Simulation and Data Analysis (CMSDA), Zhuhai, China, 2022, pp. 13-16, doi: 10.1109/CMSDA58069.2022.00009.
- [4] 14.R. Oumghar, M. Chraygane, H. Outzguinrimt and M. Lahame, "Modeling of High Voltage Three-Phase Power Supply Using Five-Limb Magnetic Shunt Transformer," 2019 International Conference of Computer Science and Renewable Energies (ICCSRE), Agadir, Morocco, 2019, pp. 1-7, doi: 10.1109/ICCSRE.2019.8807486.
- [5] X. Liu, T. Pan and G. Zhong, "Design of three-phase class E power amplifier based on wireless power transmission system," 2018 13th IEEE Conference on Industrial Electronics and Applications (ICIEA), Wuhan, China, 2018, pp. 2573-2577, doi: 10.1109/ICIEA.2018.8398145.
- [6] M. -S. Goh, J. -T. Kim, S. -h. Park, S. -S. Choi and I. -D. Kim, "Design of Three-Phase Three-Switch PWM Current Source Rectifier/Inverter of Induction Heating Power Supply for Forging Applicationsaper," 2020 IEEE 9th International Power Electronics and Motion Control Conference (IPEMC2020-ECCE Asia), Nanjing, China, 2020, pp. 2806-2811, doi: 10.1109/IPEMC-ECCEAsia48364.2020.9367823.
- [7] Weedy, B., Cory, Jenkins, N., Ekanayake, & Strbac. (n.d.). Electric Power Systems Electric Power Systems. <http://files.hostgator.co.in/hostgator253199/file/electricalpowersystem.pdf>
- [8] Maloberti, F., & Davies, A. (n.d.). CIRCUITS AND SYSTEMS A SHORT HISTORY OF. [https://ieeecas.org/files/ieeecas/2022-01/a\\_short\\_history\\_of\\_circuits\\_and\\_systems-\\_ebook-\\_web.pdf](https://ieeecas.org/files/ieeecas/2022-01/a_short_history_of_circuits_and_systems-_ebook-_web.pdf)
- [9] Understanding Basic Electricity and Electronics LOUISIANA DEPARTMENT OF TRANSPORTATION AND DEVELOPMENT LOUISIANA TRANSPORTATION RESEARCH CENTER TECHNOLOGY TRANSFER AND TRAINING 2018. (n.d.). <https://www.ltrc.lsu.edu/pdf/STT201-BasicElectricity.pdf>
- [10] Single-Phase Series A.C. Circuits Learning Outcomes. (n.d.). <https://booksite.elsevier.com/samplechapters/9780750687478/9780750687478.pdf>
- [11] Fleckenstein, J. (n.d.). Calculating and Measuring Power in Three Phase Circuits Calculating and Measuring Power in Three Phase Circuits. <https://pdhonline.com/courses/e344/e344content.pdf>