

Smart DB Monitoring

Mohammad Al Sardiaan Syah Ansar¹, Maizul Ishak^{1*}

¹Department of Electrical Engineering Technology, Faculty of Engineering Technology,
Universiti Tun Hussein Onn Malaysia, 84600 Pagoh, Johor, MALAYSIA

*Corresponding Author Designation

DOI: <https://doi.org/10.30880/peat.2021.02.02.061>

Received 24 June 2021; Accepted 07 October 2021; Available online 02 December 2021

Abstract: Technology has become an important aspect of the current modern world. The existence of it keeps evolving into various applications and machinery that help to reduce the burden on any work in daily life. The key to this rapid advancement is the electrical energy that has become the thing that powered up all these technologies. However, users have become careless and ignore the importance of saving electricity. Electrical appliances at a household were keep switched ON even though it is unused and not monitored resulting in energy waste. This issue can be solved by the presence of IoT (Internet of Things) technologies that can do things wirelessly with the presence of an Internet and smartphone. The development of IoT has introduced various smart systems and one of them is the ability to monitor the power consumption at home from the smartphone or any built website. This project aims to monitor the current from different MCB. By using ESP32 with Blynk application interface. The user can monitor at the same time control their home appliance by using a smartphone through the internet. The system consists various type of sensor as input. Current transformer and voltage sensor were used this will help the user monitor their power usage at home.

Keywords: Internet of Things, Current Transformer, Monitoring, Distribution Box

1. Introduction

Electricity or power is the main key in our daily basis. Generally, in any industry such as domestic and commercial, there are numerous types of a distribution box, and systems were used. This distribution box is designed or installed based on the load rating. The important aspect in the industry is proper domestic installation. The circuit breaker inside the distribution board (DB) should be more high rating compared to the installed load [1][2].

In either place, whether in our home or at work, the safety of any human being has always been paramount., but we are generally not aware of it until an unusual incident has happened, either triggered by lightning strikes, overloads, or defective equipment. A widespread issue in domestic areas has been the loss of the electrical power supply due to temporary and/or permanent faults, and the traditional process of repairing the power supply typically takes time. In certain cases, manual power supply repair is usually carried out [3][4]. Until today, consumer only know our total load usage every month when

the electric bill has come out. Therefore, the monitoring system has been proposed to monitor the real-time current usage in our house [5][6].

Table 1 shows the previous research that related to smart DB monitoring. From the previous research, there are lots of different microcontrollers used to monitor the current and power consumption in home appliances. For example, using Programmable Logic Control (PLC), 51single chip Processor, Arduino, and microcontroller89c91. There are also various sensors used for the previous research to achieve the monitoring system such as current inducer, humidity transducer, temperature transducer, and others.

Table 1: Previous roject that related to project

NO	Title of project	Implementation	Comments
1	Household power outlet overload protection and monitoring using cost effective embedded solution [3]	<ul style="list-style-type: none"> Using Programmable Logic Control (PLC) Input sensor: <ul style="list-style-type: none"> Current Sensor Output: <ul style="list-style-type: none"> Socket Outlet. LED indicator Solid state relay Operation: <ul style="list-style-type: none"> Read the data from the electrical current sensor and take action if an overload is detected. 	<ul style="list-style-type: none"> Smart home that can automate and control a variety of household equipment to improve convenience, comfort, energy efficiency, and security. Able to monitor the power used by the power outlet and able to notify the user.
2	Design and implementation of state monitoring system for distribution box [7]	<ul style="list-style-type: none"> 51singlechip Processor Input: <ul style="list-style-type: none"> Current inducer. Humidity Transducer. Temperature Transducer. Operation: <ul style="list-style-type: none"> The humidity transducer, temperature transducer, and current induction coil data collecting. 	<ul style="list-style-type: none"> Designing a monitoring system to detect junction faults which is the first step analysing the cable temperature and humidity. After that, upload the cable data through the cloud. Also, display the cable status in real time. Finally, have its own alarming function when the cable is in poor condition.
3	Online Monitoring System for Domestic Distribution Box [5]	<ul style="list-style-type: none"> Arduino Input: <ul style="list-style-type: none"> Voltage sensor Current sensor Output: <ul style="list-style-type: none"> Solid state relay Operation <ul style="list-style-type: none"> Remotely control the circuit breakers and monitor the continuity of the incoming electricity using a smart device. 	<ul style="list-style-type: none"> Designing a monitoring system for domestic DB. Which is IOT system sends the data gained from the sensor to be stored to Multiple SQLite-database. When the fault happens inside the distribution box, the system will immediately notify the user that fault has happened.

- 4 Way to Monitor Power in Industry [8]
- Microcontroller 89c51
- Input:
- Temperature sensor
 - Current Sensor
- Output:
- Display
 - GSM
- Operation:
- Monitor the distribution box's health, including its power, voltage, current, temperature, humidity, MCB status, and power availability, among other things.
- Monitor the temperature, humidity and current through internet while using a microcontroller to process the data and display to LCD.
 - Furthermore, the system also has GSM module to warn the user.

2. Development of Smart DB monitoring

Figure 1 is the project design of smart DB monitoring which consists of a home DB and monitoring system. This project fully utilizes The Blynk application which consists of several features where user can view details on energy consumption. One of the features can view data or the labeled data widget used for data visualization from the current transformer and voltage sensor. While at the same time users can monitor the graph of the average energy usage over time using the SuperChart widget.

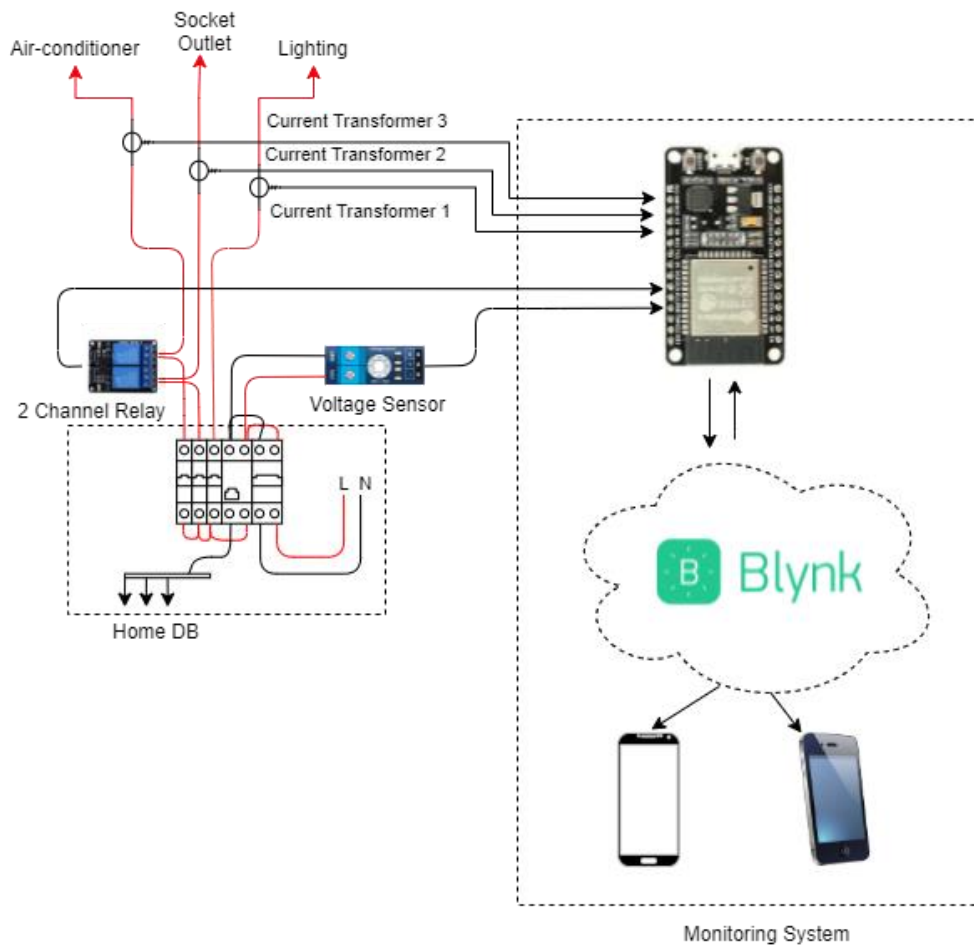

Figure 1: Project Design

2.1 List of materials used for the smart DB monitoring

The project using various sensors to achieve the objective of project. For the electrical components, ESP32 is used as the microcontroller for the project which is playing the main role for the project to work perfectly. The ESP 32 consist of 39 input and output pins and 18 analog pins. For project 4 analog pin is used for the sensor this is because the sensor has an analog output. So, the sensor should be connected to analog input. Next, the current transformer for the project is SCT013 also known as a split-core current transformer. The sensor can be easily used just by a clamp around the live conductor of the electrical load to provide how much current that passes through the conductor. 2-Channel relay used in this project to control the socket outlet. The relay will be energized when it receives the signal from the microcontroller. Finally, DB peripherals that works as the supply voltage for the socket-outlet.

Table 2: List of materials

Component	Item	Description
1. Electrical components	- ESP32	- 39 pins (of which 34 is a normal GPIO pin) with 18 analog pins.
	- Current Transformer	- To measure current.
	- Voltage sensor	- To measure incoming voltage.
	- 2-Channel Relay	- To control socket outlet 2 and socket outlet 3
2. Others	- DB peripherals	- MCB, RCCB, wires, and socket outlet.
	- Wooden Board	
	- Heat shrinkable tubing.	
	- PVC Enclosure Box	

2.2 Flowchart for the monitor and control system

Figure 2, shows the flowchart of the monitoring system of smart DB Monitoring. The first part of the system will start when the ESP32 is powered up and automatically connect to the Wi-Fi. This will give internet access for ESP32 to interface with the blynk application.

The operation continues with the voltage sensor and current transformer (SCT013) installed in the system. The purpose of this sensor is to monitor the electrical load of home installation. Since the socket-outlet is used for the project. various types of load can be used as the electrical load such as induction cooker, water heater, lamp, fand and others. When the sensor detects the current and voltage it will produce an analog signal and send it to the ESP32. ESP32 will receive and process the data. The data that has been processed by the ESP32 will be displayed at a 16X2 LCD screen on the control box that allows the user to monitor the power consumption without the internet. After that, ESP32 will send the data to the blynk application. The data then will be visualised in the blynk application so that the user can monitor their power consumption with the help of an internet connection without have to look at the control box.

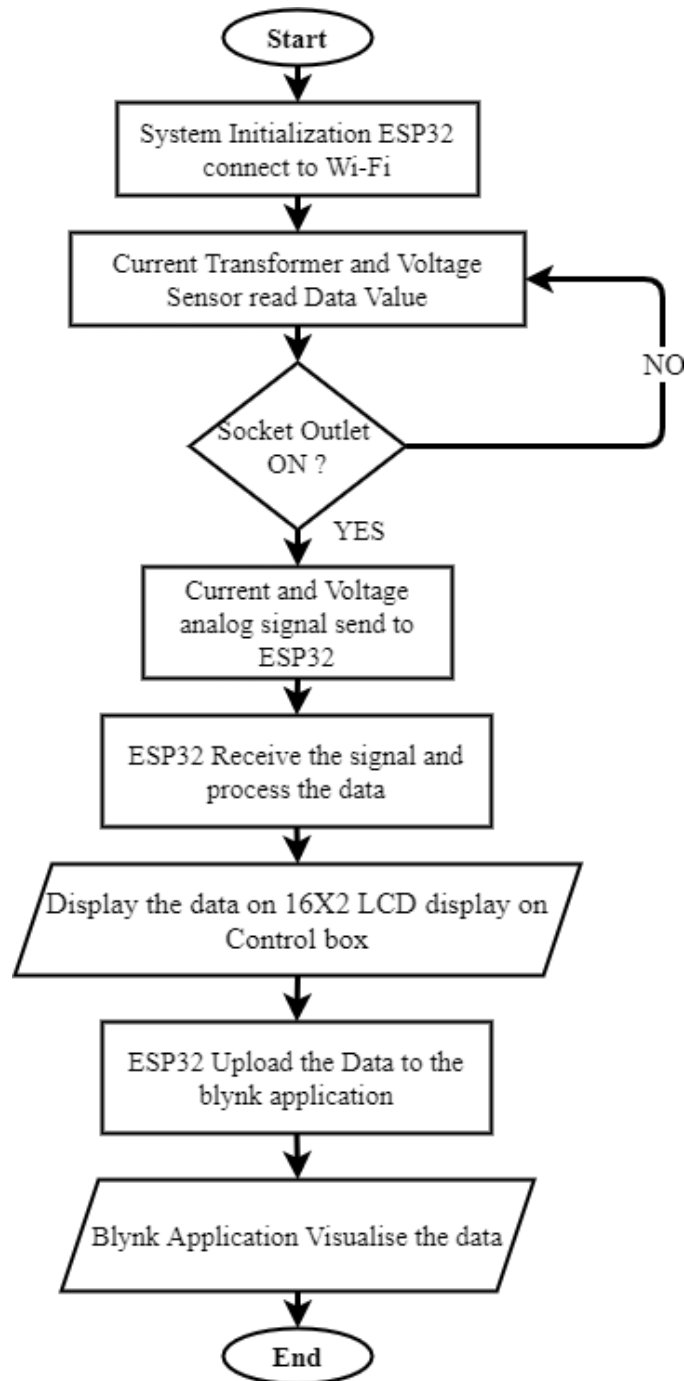

Figure 2: Flowchart of monitoring system

Figure 3 shows the flowchart of the control system of smart DB monitoring. The system will start by ESP32 connect the internet through Wi-Fi. This operation will allow the ESP32 to synchronize with the blynk application. The control system will start at the same flow as the monitoring system so that the system can work perfectly to achieve the Internet of Things application. For the control system there are 2 ways to control the load, the first one is using blynk application widget the second one is using the current transformer.

For the current transformer, it will detect the overcurrent from the electrical load installed. The current transformer will send the analog signal to the ESP32 to process the data. The ESP32 will analyze the data that have been received from the current transformer. If the current data is equal to or more than 90.00 % MCB rate, ESP32 will send the signal to the relay. The relay will be energized and then

will open the electrical load circuit. On the blynk application widget, the ON button state will de-energize the relay and the electrical load will on. This is because the live conductor of the electrical load has been connected to the normally closed relay. Therefore the OFF button state will energize the Relay and it will open the circuit. So the electrical load can not operate.

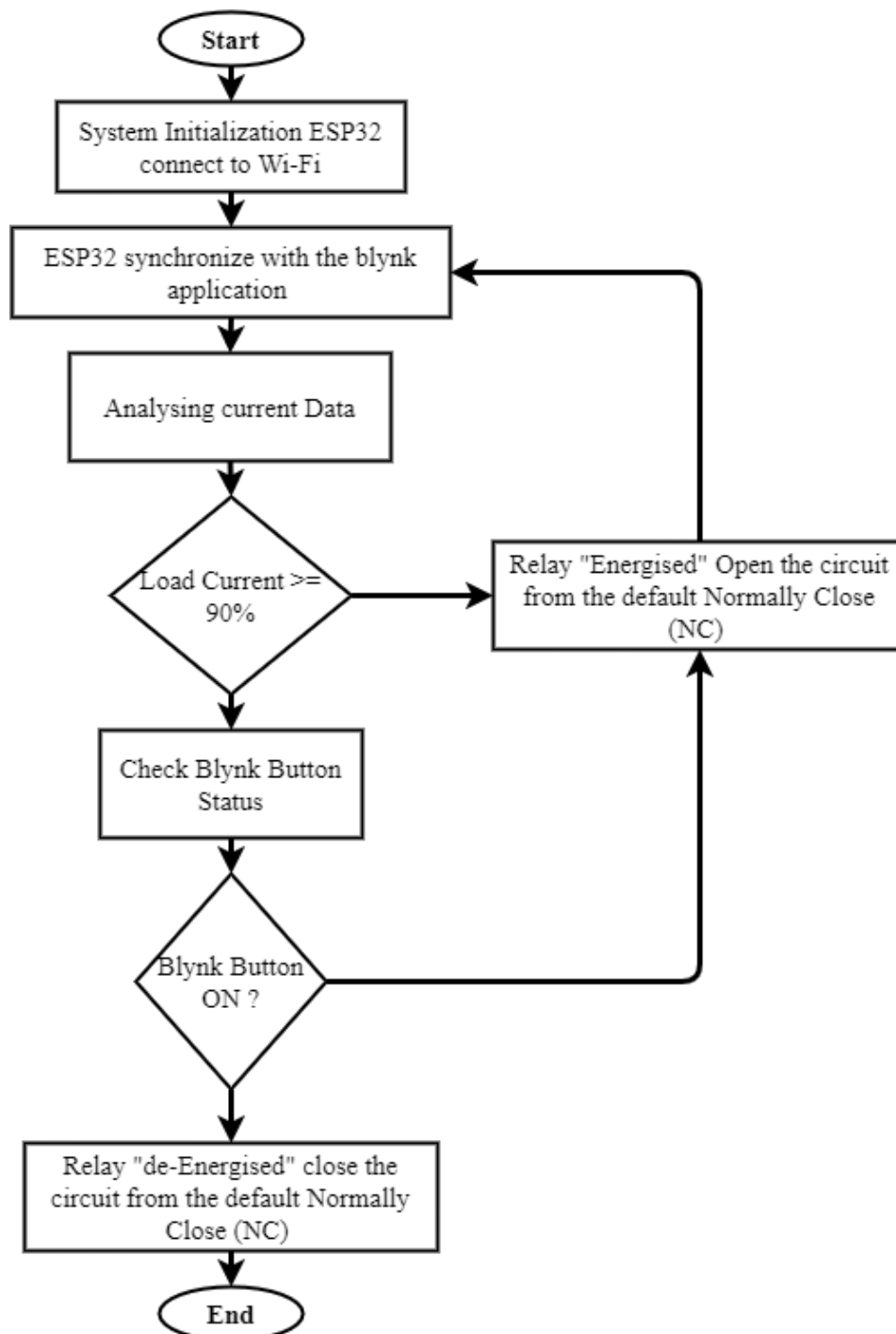

Figure 3: Flowchart of control system

2.3 Block Diagram of the Project

Figure 4, shows the basic procedure on how to carry out the objective for the project. the system consists of a sensor, microcontroller, relay module, electrical load, and blynk application. There are 2 types of sensor used, current transformer and voltage sensor. The current transformer will clamp on the live conductor of the electrical load and send the analog signal to the ESP32 to be processed.

The voltage sensor will tap on the incoming supply voltage to be measured. The voltage sensor will measure the voltage and send the analog signal to the ESP32 to be processed. The ESP32 will initialize the system and connect to the internet via a Wi-Fi connection. ESP32 will receive all the analog data that was sent to it. The data will be processed before it can be visualized in the blynk application.

Blynk application will synchronize with ESP32 to make sure the system works fine. blynk will visualize the data that has been received from the ESP32 such as current, voltage, and Power. There are also button widget on the blynk application to control the electrical load via relay module.

The relay module will control the electrical load which is to open or close the circuit. This will work when the ESP32 send the digital signal to the relay module and the relay module will operate based on the signal received.

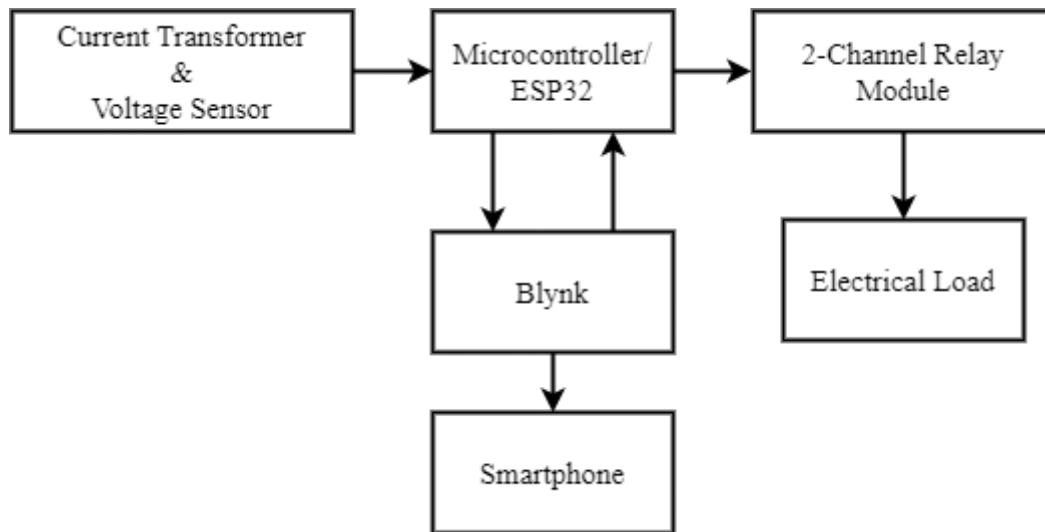

Figure 4: Block diagram of the project

3. Results and Discussion

Completed design of the project and it is ready to monitor the desired data. From this project, the data will be taken from the installed DB. But before taking some results, the sensor should be calibrated by following the clamp meter value. From the Figure 5, smart DB monitoring is consist of various part such as Home DB, current transformer (CT 1, CT 2 and CT 3), socket 1, socket 2, socket 3 and controller box.

The live conductor passes through the controller box before it goes to the socket outlet. This is because the live conductor on the control panel box will be connected with the relay module before the socket outlet. Next, the current transformer will be clamped to a different conductor. For example, CT 1 clamp-on socket 1, CT 2 clamp-on socket 2, and CT 3 clamp-on socket 3. The reading will be easily taken and easy to monitor or troubleshoot if the problem happens.

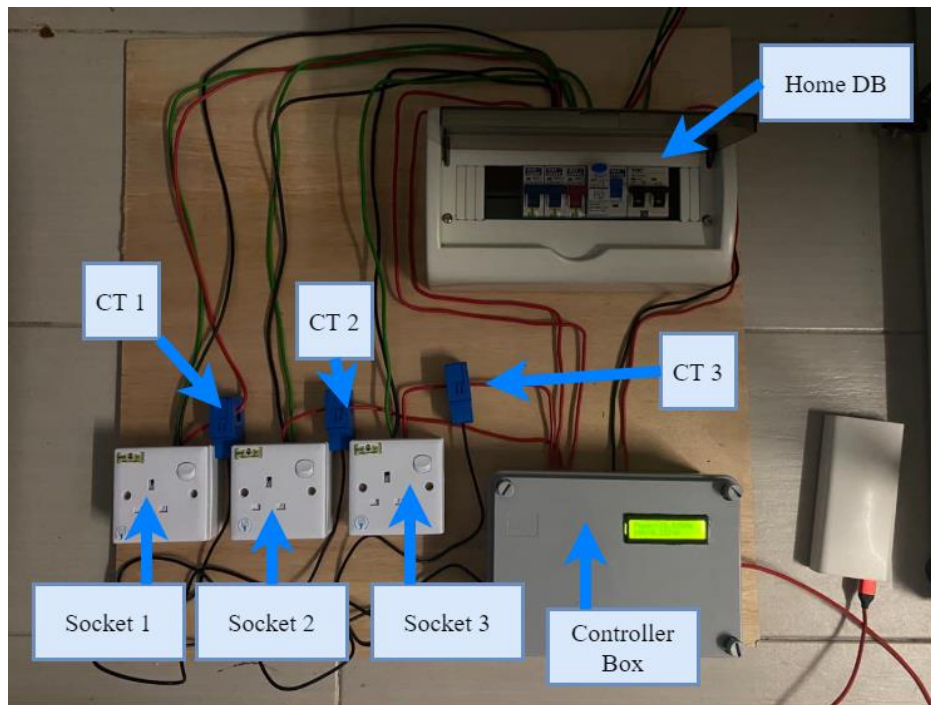

Figure 5: Final Design of the Project

3.1 Controller Box

Inside the controller box in figure 6, there are consists of ESP32 as the microcontroller, Voltage sensor which is to measure incoming supply voltage. 2-Channel Relay module which is to control socket 2 and socket 3. Furthermore, 16X2 LCD works to visualize the data with or without an internet connection. Finally, the filter board circuit for the current transformer so that it can work normally. The code also has integrated if-else statement, so when the current for socket 2 and socket 3 is equal or higher than 90.00 % the relay will automatically open the circuit.

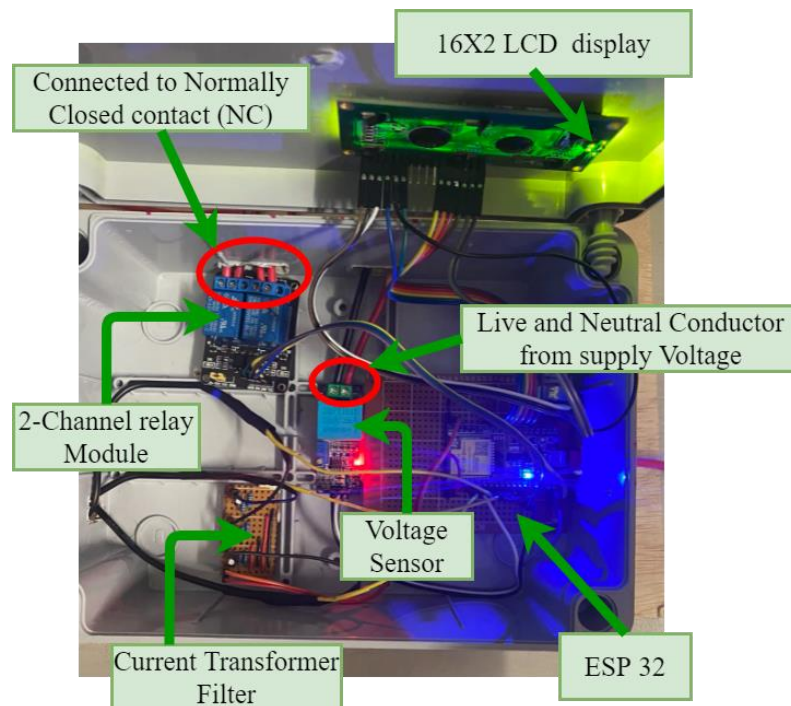

Figure 6: Controller Box

3.2 Control System of Smart DB Monitoring

From Figure 7, the demonstration was presented of the control system of smart DB monitoring. For this project, 2 relays are used to control the electrical load. The relay for sockets 3 and 2 works to control the current flow by open or close the circuit.

Since the button for socket 2 widget on blynk application is turned ON, the relay for socket 2 is de-energized and stays as the default normally closed which allows the current flow through socket 2. The button for the socket 3 widget on blynk application is turned OFF, the relay for socket 3 is energized as shows in the light indicator in the figure. This means the relay of socket 3 is changing state from a normally close to open state. This process will block the supply voltage from going through socket 3.

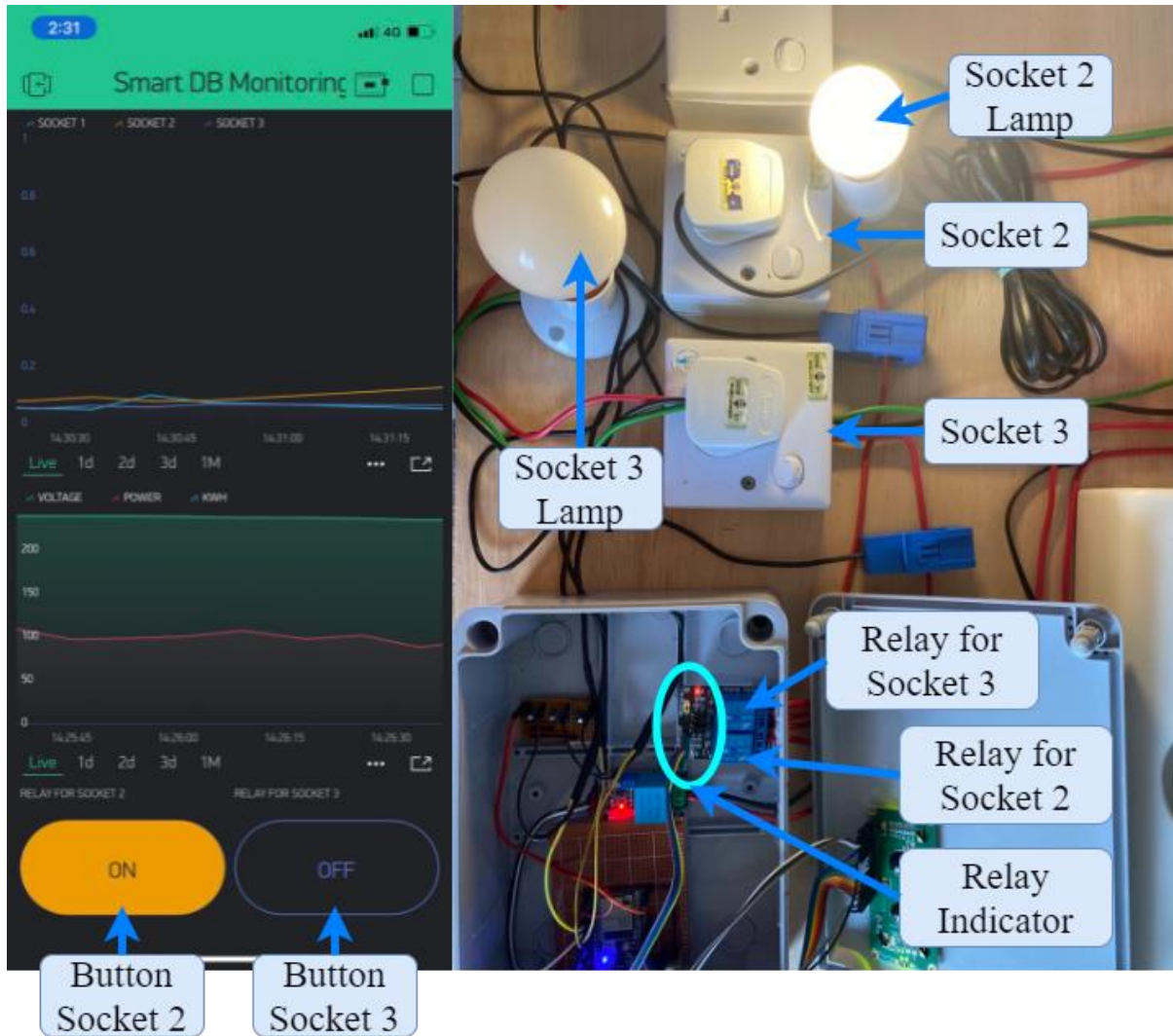

Figure 7: Controlling Socket 2 via Blynk

From Figure 8, the demonstration was presented of the control system of smart DB monitoring. For this project, 2 relays are used to control the electrical load. The relay for sockets 3 and 2 works to control the current flow by open or close the circuit.

Since the button for socket 3 widget on blynk application is turned ON, the relay for socket 3 is de-energized and stays as the default normally closed which allows the current flow through socket 3. The button for the socket 2 widget on blynk application is turned OFF, the relay for socket 2 is energized as shows in the light indicator in the figure. This means the relay of socket 2 is changing state from a normally close to open state. This process will block the supply voltage from going through socket 2.

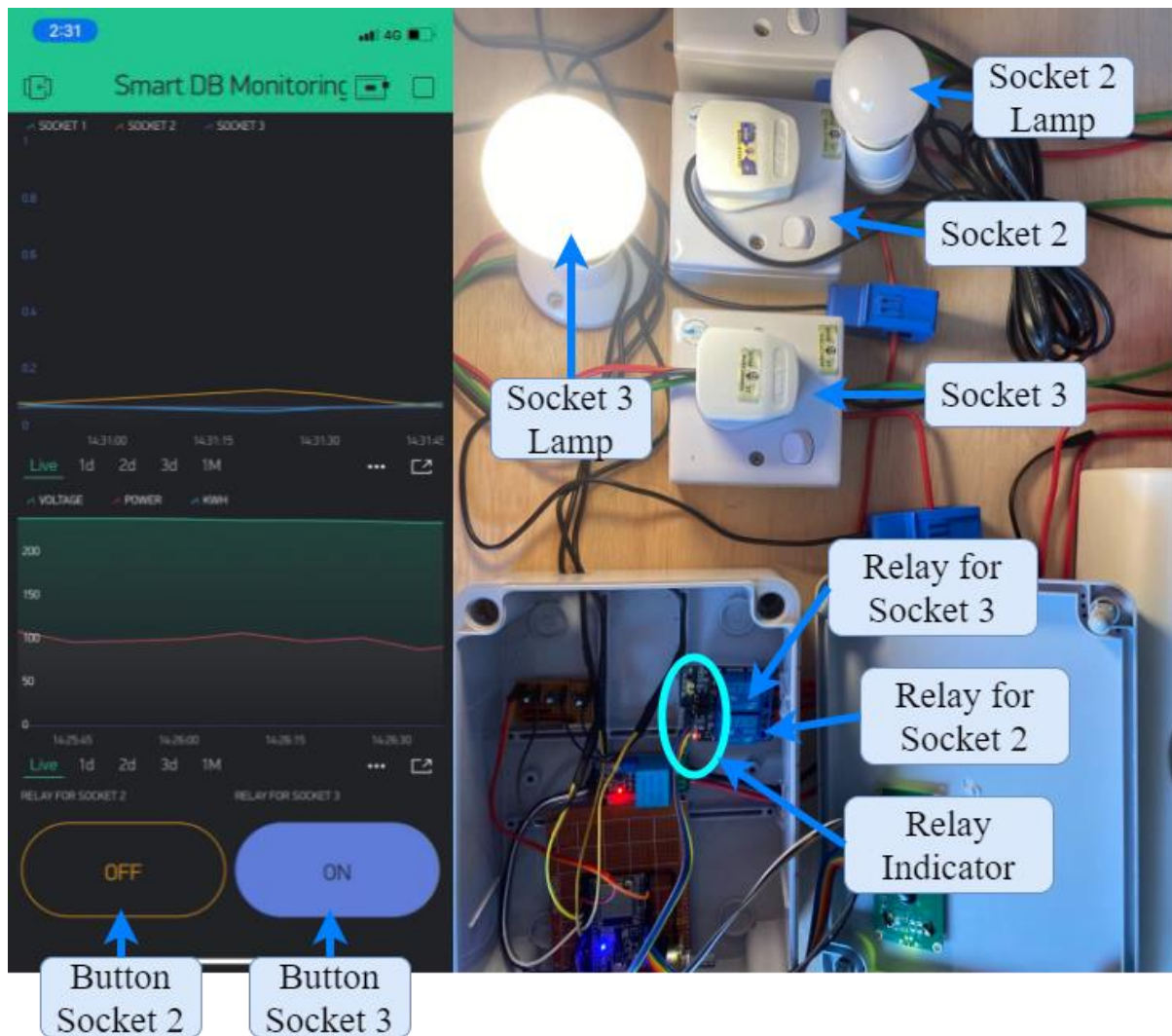

Figure 8: Controlling socket 3 via Blynk

3.3 Monitoring System of Smart DB Monitoring

The project continued by monitor the power consumption of 3 sockets with 3 different loads, there is total 3 current transformer that has been clamp for each live conductor of the socket. The first one is the smartphone charger on socket 1, fan on socket 2, finally laptop charger on socket 3. The data will be taken for 1 day to look at the behavior of power consumption of daily usage. This operation will prove the ability of the system to measure the power consumption of the electrical load as in figure 9. The data will be uploaded to the blynk application to be visualized as shown in Ffigure 9 such as voltage, socket 1,2,3 current, total power, and kWh.

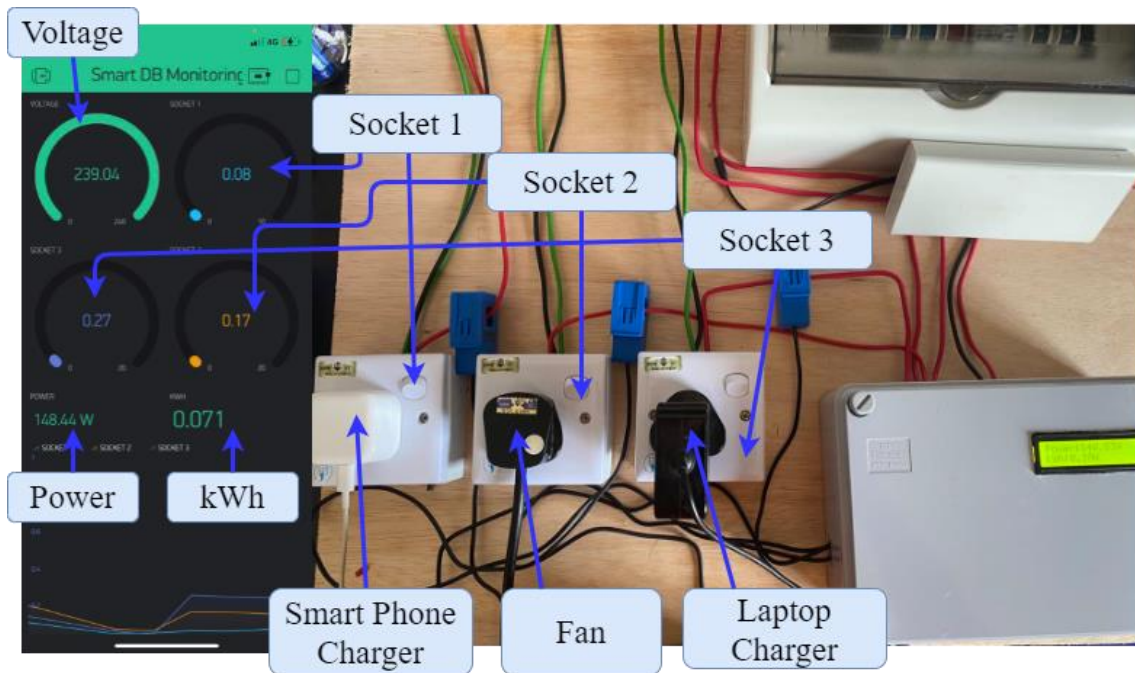

Figure 9: Electrical load for Monitoring operation

Figure 10, shows the graph of power consumption that has been taken for 1 day. The observation on the blynk application reading shows the current usage for 3 different current transformers which are socket 1 socket 2 and socket 3. For socket 1, from 12:00 AM to 7:00 AM the current slowly rising from 0.10 A to the peak of 0.70 A since it is the smartphone charger. After that from 7:00 AM to 12:00 PM the current drop to 0.08 A which means no load. The current reading in blynk application around 0.00 A to 0.80 A with no load occurs because the noise of the current transformer filter.

For socket 2, from 12:00 AM to 9:00 AM the current maintain around 0.15A this is because socket 2 is using the fan. After that, from 9:00 AM to 12:00 PM the current drops to 0.08A which means the fan has been turned OFF so there is no current alongside the conductor. The 0.08A of current is the noise produced by the current transformer filter.

For socket 3, from 12:00 AM to 7:00 AM the current average is around 0.3 to 0.7 this is because for socket 3 electrical load is a laptop charger. For 7:00 AM to 12:00 PM the current drop to 0.08 means that the laptop charger has been turned OFF so there are no current runs alongside of the conductor.

The voltage reading for 1 day stays around 240 V, the voltage reading was taken from the voltage supply from the DB. The power reading depends on the current and voltage readings from the sensor. From the graph in figure 10, from 12:00 AM to 7:00 AM the power usage is increased a bit from 200.0 W to 300.0 W. From 7:00 AM to 12:00 PM the power suddenly drops to 35.0 W since all the socket has been turned off. The 35 W produced on blynk is because the current transformer filter sends the current reading around 0.08 A. Therefore, the calculation of power will be affected, the noise of power will be a range of 21.6 W to 57.0 W at no load.



Figure 10: Power usage for 1 day of Smart DB monitoring

3.4 Blynk application Live current reading

Figure 11 shows the blynk application for the live reading of socket 1, socket 2, and socket 3. The load for socket 1 is a smartphone charger, the load for socket 2 is a fan and the load of socket 3 is a laptop charger. The reading on the blynk application will be uploaded to the graph widget. The consumer or user can monitor their power consumption by value visualization or graph visualization. The total power is also presented to monitor the power in real-time value. The kWh will record the total power usage of electrical load connected through smart DB monitoring. The voltage is also shown in the figure which is around 238.12 V. When there is no supply voltage, the user can monitor inside the blynk application widget.



Figure 11 : Blynk application live reading

3.5 Graph of current on socket 1

Figure 12 shows the current reading that has been used for socket 1 in excel that has been exported from blynk application. From 8:45 PM the current reading is around 0.18 A, the current seems unstable for the smartphone charger that plugged in the socket outlet 1. The data is measured around 1 and half hours to analyze the current usage of electrical load. Around 9:45 PM to 9:50 PM the current reading is around 0.08 A which means the socket is turned off. The 0.08 current reading is due to the noise of the current transformer filter board. If there is no load, the filter board will produce noise that makes the current reading around 0.00 A to 0.08 A with no load.

Date: 1 July 2021

Time: 8:45 PM – 10:20 PM

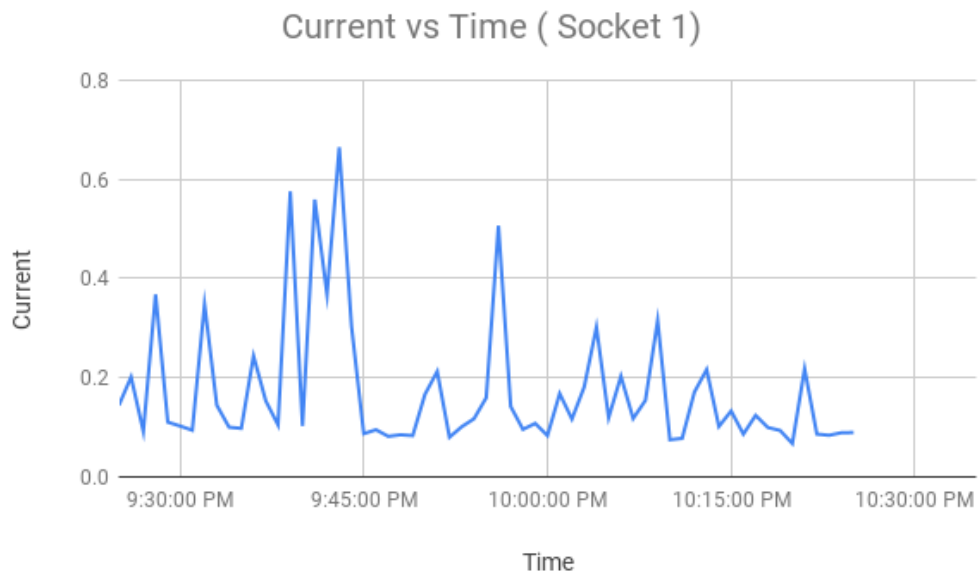

Figure 12: Graph of socket 1 vs time

3.6 Graph of current on socket 2

Figure 13 shows the current reading that has been used for socket 2 in excel that has been exported from blynk application. around 2:45 PM the current reading is around 0.18 A, the current reading has a spike a little for the fan that plugged in the socket outlet 2. But overall the current on socket 2 is maintained which is around 0.15 to 0.16. The data is measured around 1 hour to analyze the current usage of electrical load.

Date: 1 july 2021

Time: 2:30 PM - 3:30PM

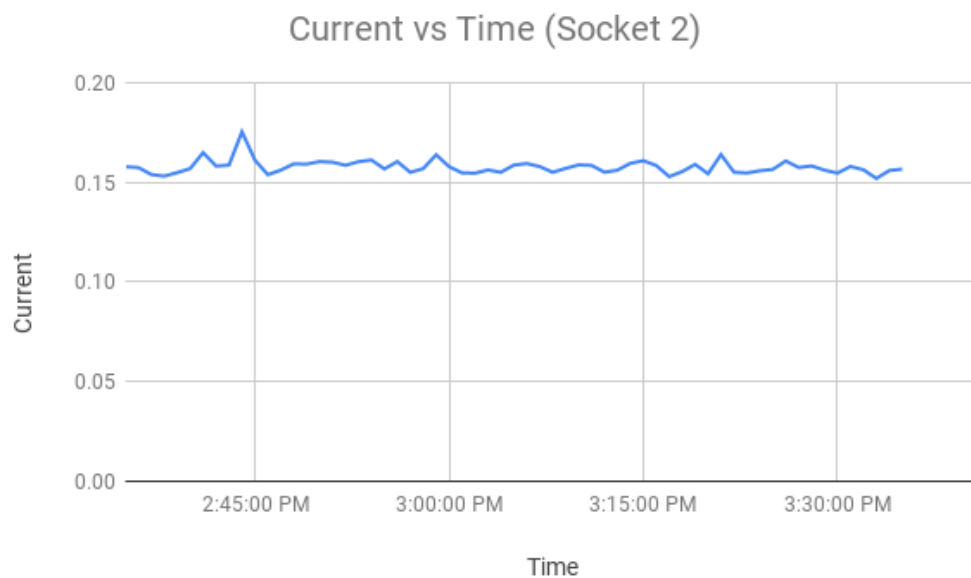

Figure 13: Graph of socket 2 vs time

3.7 Graph of current on socket 3

Figure 14 shows the current reading that has been used for socket 3 in excel that has been exported from blynk application. From 2:30 PM the current reading is around 0.50 A, the current seems unstable for the laptop charger that plugged in the socket outlet 3. The data is measured for around 1 hour to analyze the current usage of electrical load. Around 2:55 PM to 3:00 PM there is a current spike around 1.70 A this is because the noise of the current transformer filter board make the current sudden increase in a period.

From the total 3 current measured using smart DB monitoring from a different socket, the charger seems a bit unstable this occurs since the noise of the current transformer filter board that makes the reading for the charger changed unexpectedly. The current reading of socket 2 seem normal in the period.

Date: 1 july 2021

Time: 2:30 PM - 3:30 PM

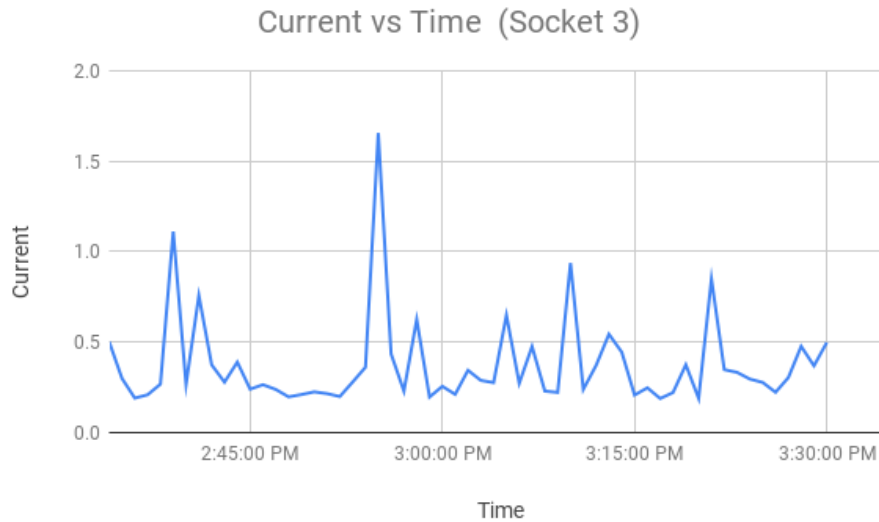

Figure 14: Graph of socket 3 vs time

3.8 Graph of supply voltage

Figure 15 shows the voltage reading that has been recorded using a voltage sensor with ESP32 that has been extracted from the blynk application. The voltage reading is normal which is around 240 V. the voltage data has been taken for 1 hour to be analyzed. Monitoring a voltage in this project work very well in the result. Since it is not affected by the current transformer filter. The voltage sensor has a build-in signal filter because it comes with the module itself.

Date: 1 July

Time: 2:30 PM – 3:30 PM

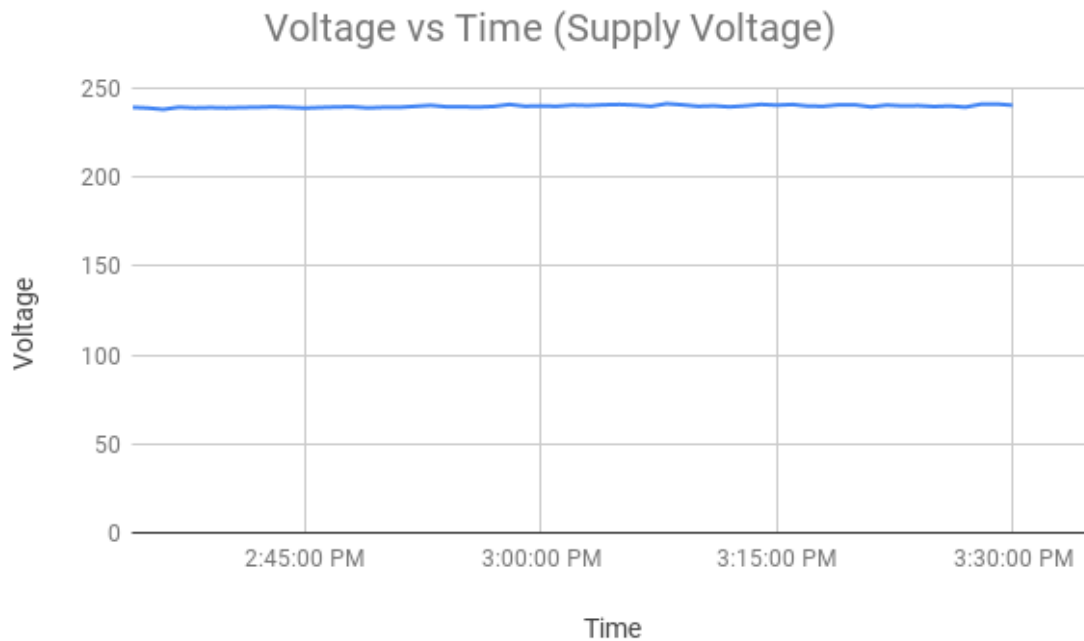

Figure 15: Graph voltage vs time

3.9 Graph of total power with 3 electrical load

The total power in Figure 16 shows power consumption with 3 electrical loads. The first load is socket 1 that is a smartphone charger, the second is socket 2 which is a fan, and finally, socket 3 is a laptop charger. The current of each socket can be sum up and multiple by the total current to produce the power. The calculation is being done by the ESP32 with the coding to increase the accuracy of the reading. The power will increase when the current increase as the graph in figure 10. Around 12:00 PM to 5:00 PM the current increase at the same time, the power also increases.

Date: 1 July 2021

Time: 2:30 PM – 3:30 PM

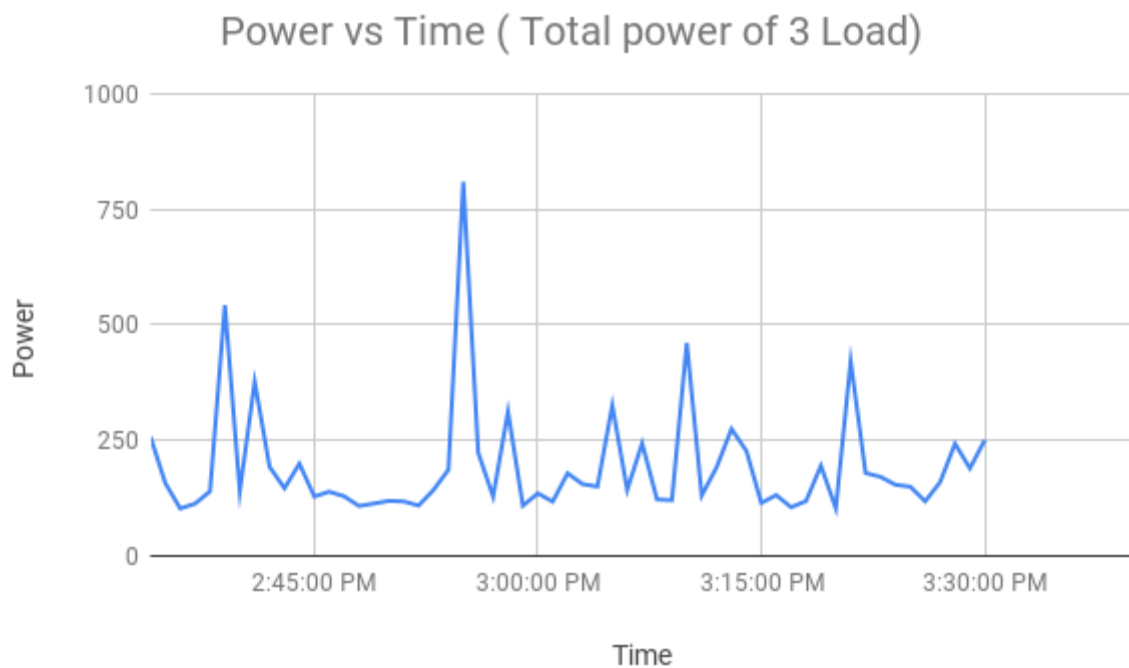

Figure 16: Graph power vs time

3.10 Graph of kWh consumption

Figure 17 is the kWh power consumption of smart DB monitoring with 3 sockets. The socket 1 electrical load is a smartphone charger, socket 2 is a fan, and socket 3 is a laptop charger. The load is taken around 14 hours and 30 minutes which is from 12:30 AM to 3:00 PM. Theoretically, the kWh will increase over time due to the total power consumed by the electrical load. The figures show the kWh increased from 0.25 kWh to 1.05 kWh around 14 hours of operation. In this result, the user can monitor their kWh usage. This will give the user to manage their electrical load easily at the same time they can save their money for the upcoming bills this is because they can monitor how much kWh consumed and calculate the upcoming bills.

Date: 1 July 2021

Time: 12:30 AM – 3:00 PM

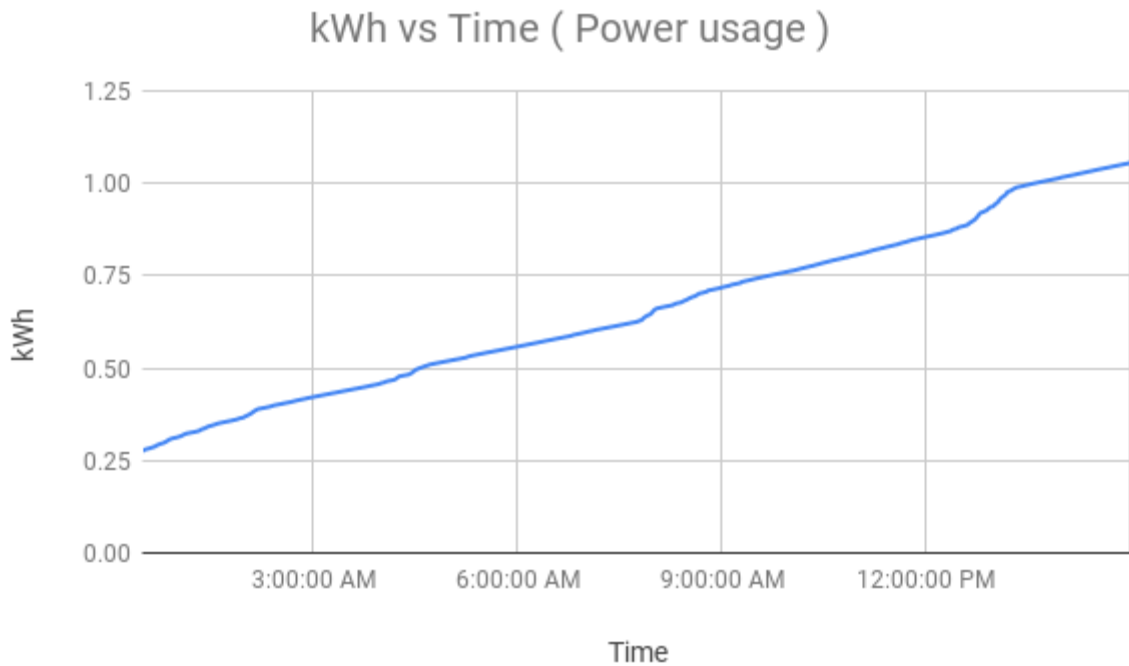

Figure 17: Kwh vs Time (Power Consumption)

4. Conclusion

Making the smart DB monitoring was a fantastic experience. This project has achieved all of the proposed objectives. Designed Smart DB Monitoring which consists of ESP32 microcontroller including 4 sensors and 1 relay module. The sensor consists of 3 current transformers and 1 voltage sensor to measure the current of each socket outlet and the incoming voltage supply. Developing a precaution step in preventing overcurrent happen by control with the relay module when the current is equal to or more than the load rating of the miniature circuit breaker the relay will be energized and open the circuit to prevent the overcurrent. The electrical load also can be manually turned ON or OFF by pressing the button widget in the blynk application. Finally, Able to monitor power usage through the internet by using blynk application on the smartphone as in the result where the user can monitor the current, voltage, power, and kWh in the blynk application the data uploaded in the blynk can be exported in CSV files that is easy to manage in the excel.

Acknowledgement

The authors would like to thank the Faculty of Engineering Technology, Universiti Tun Hussein Onn for its support.

References

- [1] M. S. B. A. Muhammad Faizal Bin Ismail and S. N. B. M. R. Hanis Arina Binti Mohd Ridzuan, "HOME DUINO: A SMART HOMES CONCEPT," *An Autom. Irrig. Syst. Using Arduino Microcontroller*, vol. 1908, no. January, pp. 2–6, 2011.
- [2] J. S. Hassan, R. M. Zin, M. Z. A. Majid, S. Balubaid, and M. R. Hainin, "Building energy consumption in Malaysia: An overview," *J. Teknol.*, vol. 70, no. 7, pp. 33–38, 2014, doi: 10.11113/jt.v70.3574.
- [3] G. Horvat, D. Vinko, and D. Zagar, "Household power outlet overload protection and monitoring using cost effective embedded solution," *Proc. - 2013 2nd Mediterr. Conf.*

- Embed. Comput. MECO 2013, no. 165, pp. 242–246, 2013, doi: 10.1109/MECO.2013.6601368.
- [4] S. Ali and D. Kim, “Visualization methodology of power consumption in homes,” ICOSST 2013 - 2013 Int. Conf. Open Source Syst. Technol. Proc., pp. 55–59, 2013, doi: 10.1109/ICOSST.2013.6720606.
- [5] T. J. Hau, “Online Monitoring System for Domestic Distribution Box,” J. Chem. Inf. Model., vol. 53, no. 9, pp. 1689–1699, 2019.
- [6] A. Othman and N. H. Zakaria, “Energy Meter based Wireless Monitoring System using Blynk Application via smartphone,” pp. 1–5, 2020, doi: 10.1109/iicaiet49801.2020.9257827.
- [7] H. H. Qasim, A. E. Hamza, L. Audah, H. H. Ibrahim, H. A. Saeed, and M. I. Hamzah, “Design and implementation home security system and monitoring by using wireless sensor networks WSN/internet of things IoT,” Int. J. Electr. Comput. Eng., vol. 10, no. 3, pp. 2617–2624, 2019, doi: 10.11591/ijece.v10i3.pp2617-2624.
- [8] M. Shivani, “Way to Monitor Power in Industry,” no. Icoei, pp. 214–216, 2020.