

## Modern Coffee Table Inspired by Traditional Chinese Lantern

Goh Hui Yin<sup>1</sup> & Abdullah Al Rashid Ab Hamid<sup>1,\*</sup>

<sup>1</sup>Department of Production and Operations Management, Faculty of Technology Management and Business, Universiti Tun Hussein Onn Malaysia, Batu Pahat, Johor, 86400, MALAYSIA.

\*Corresponding Author

DOI: <https://doi.org/10.30880/rmtb.2021.02.01.034>

Received 01 March 2021; Accepted 30 April 2021; Available online 01 June 2021

**Abstract:** Coffee table is a common fixture of modern interiors that is important in life. The users often encountered problems in their living room. For example, multiple remotes scattered across the coffee table, messy papers and magazine clippings cramping the style, and those stained takeout menus cannot seem to part with. The objective of this study was to identify the characteristics of a modern coffee table that apply the elements of the Chinese style in designing patterns and can be store the pile of sundries, tea sets and to develop a prototype of a modern coffee table in the living room. The target user was the nuclear family which was a family group consisting of two-parent and one or more children. The area of the survey was in my hometown which was Taman Indah Jaya at Teluk Intan, Perak. The main areas of study were research, design development, and prototype. This research was conducted using questionnaires to determine the design criteria of the coffee table. Besides that, design development required hand sketching for ideas which were thumbnail sketching, idea development, ideation, mock-up, AutoCAD technical drawing, and final design. The top of the final prototype product was made by multi-plywood according to the final design. This survey was conducted with 146 respondents and collected data on the design criteria of the modern coffee table from the respondents. This research would become the future reference for the students who were preparing their assignment or final year project.

**Keywords:** Coffee table, Traditional Chinese lantern, Modern

### 1. Introduction

#### 1.1 Research Background

The living room is considered the focal point of the house where daily activities take place. In traditional Malaysian families, the family members gather in the living room to discuss or communicate about domestic matters or just to spend time with them (Saruwono *et al.*, 2012). Everyone needs a coffee table in their home, it creates an elegant centerpiece for the room, provides an area to put drinks or books, and occasionally a place to work on your laptop.

The coffee table may be used to hold decorative objects or food and drinks. Within the space of the living room provided, occupants would give a great deal of time and resources to organize the living room furniture depending on their personal preferences, needs, and priorities (Saruwono *et al.*, 2012). According to Edward *et al.* (2000), it is noted herein, as is known to those skilled in the art, that even though the term coffee table is used throughout this application, coffee tables also serve as and are interchangeable with end tables, Smack tables which may be located in front of or to the side of a user.

Lacking any historical or cultural tradition, modern furniture also provided the grounds for the creations of the future. The modern design offered rectilinear, smooth, polished, and comfortable furniture for the new citizen (Hasirci & Ultav, 2019). As a popular folk custom of exquisite craft, a lantern is usually welcomed by people and touted by ancient literati, featuring a critical part in fork culture. Geographically affected by Chinese culture, countries like Japan, Singapore, and Korea would like to import some lantern crafts from China for decoration during festivals (Wang, 2018).

## 1.2 Problem Statements

The coffee table has a small footprint in the living room. Within the limited space of the living room, families must maximize the use of space virtually beyond actual dimension and diversify the use of space. To cater to the family living inside the house, furniture inside the living room is arranged in a variety of ways to fit the needs of a particular family (Saruwono *et al.*, 2012). The coffee table is very important for every family while it can make their living room more in perfect order. A coffee table is required in the living room that provides users with a convenient and accessible location for storing items that are commonly used effectively eliminate the occurrence of needing to place items on the floor or sofa (Wheat & Indianapolis, 2018).

The users often encounter problems in their living room (Deng 2017). For example, multiple remotes scattered across the coffee table, messy papers and magazine clippings cramping the style, and those stained takeout menus cannot seem to part with. Thus, the modern coffee table with the storage design can be resolving those problems. Now those items have a home that is inside the coffee table (Deng, 2017). Humans like to purchase household or accessory items resulting in there have no space to keep or collect their items. According to Newell (2018), “By the time we become aware such heaps exist, jumbling unwanted treasures, undiscardable refuse, and unused utilitarian things kept just in case, they have often already burst forth into visible space in ways that threaten the order of the home and the socially accepted structure of value”.

## 1.3 Research Questions

- (i) What are the characteristics of a modern coffee table that apply the elements of Chinese style in designing pattern?
- (ii) How to design a modern coffee table can be store the pile of sundries and tea set?
- (iii) How to produce a prototype of a modern coffee table in the living room?

## 1.4 Research Objectives

- (i) To identify the characteristics of a modern coffee table that apply the elements of Chinese style in designing pattern.
- (ii) To design a modern coffee table can be store the pile of sundries and tea set.
- (iii) To develop a prototype of a modern coffee table in the living room.

## 1.5 Scope of the Study

This research is to focus on the modern coffee table inspired by traditional Chinese lanterns which applies the elements of the Chinese style in a designing pattern. The modern coffee table is made from the elements of wood. The designs which are shape and material will be based on the respondents via questionnaire.

The target user is the nuclear family which is a family group consisting of two-parent and one or more children. The area of survey is in my hometown which is Taman Indah Jaya at Teluk Intan, Perak. This survey was conducted with 146 respondents and collect data on the design criteria of the modern coffee table from the respondents.

### 1.6 Significance of the Study

There would be an understanding and appreciation of Malaysians on traditional Chinese culture especially its pattern through this research. There also would be a potential for the message of traditional Chinese patterns to be delivered to the public. Hence, the Chinese culture would be promoted.

This research would become a future reference for the students who are preparing their assignment or final year project. The characteristics of coffee table would be preferring for a designer to improve become better and better.

## 2. Literature Review

The idea of this study is related to modern coffee table furniture. A coffee table is also called a cocktail table. Coffee table is a style of the long, low table placed in front of a sofa to support beverages, magazines, feet, books, and other small items. Coffee tables may also incorporate cabinets for storage. The idiom "Gather round the coffee table" is derived from the furniture piece and its proclivity for encouraging conviviality and light conversation.

### 2.1 Standard of Coffee Table

Although the coffee table does not have a standard height, smooth, low modern furniture will match with a table with linear lines about 15" high. Gignac (2020) stated that in the 17" to 19" range, a more traditional setting will require something beefier. He says this does not mean going the matchy-matchy route; in fact, combining styles can create a more dynamic, inviting environment. Choosing the right coffee table is very important to elevate the place in the living room.

According to Tzeses (2019), the height of the coffee table should align with the cushions of your sofa and other seating to ensure it is comfortable and aesthetically balanced. A shorter few inches of coffee table will also work well. "Coffee tables vary depend on the design from 10"-18" which is 25-46 cm" (Fantastic Offense, 2019). The height of the coffee table must be the same or lower than a sofa. The nearer the coffee table towards the sofa, the higher the height of the coffee table. Coffee tables should be approximately the same height or 2" lower than the adjacent couch.

### 2.2 Traditional Chinese Lantern

According to Deasson (2018), though the lanterns now are made in elaborate forms, from floating beauties to zodiac animals, their original purpose was simply to be a light source. The lantern was invented by the people in the ancient Eastern Han Dynasty (25-220 A.D.). The frame of the lantern is made of thin wood and covered with the smoothest silk or even glass sometimes. The silk is often decorated in traditional Chinese landscapes, flowers, birds, dragons, phoenix, fish, and so on. Lanterns vary in kind from ordinary paper lanterns, yarn lights, chandeliers, and so on (Matson, 2017).

### 2.3 Design Criteria of Coffee Table

According to Gignac (2020), the furniture's Rahim Khudabux notes that in a larger space, a small glass table would not be substantial enough; a more traditional wood table, with visual bulk and weight, appropriately anchors the space. The coffee table usually contains other uses that increase its value. The use of coffee tables not only set to their drink but also have extra storage underneath of coffee table (Tzeses, 2019).

According to Tzeses (2019), you can consider balancing the other shapes in the room by adding a circular or oval piece if everything else is rectangular. No sharp edges are more safety for smaller children. The rectangular tables are usually classic in design. But it will be harmful to children. Round and oval sides provide better options without sharp edges.

An *et al.* (2017) stated that with the progress of times and the development of science and technology, many of the traditional folk cultures and festival traditions are facing fade and alienation. The traditional Chinese lantern is an important part of traditional Chinese culture so that it must be spread and publicize to users. According to Di (2018), the direct use of traditional decorative patterns in modern furniture can more clearly express the design intention. However, the decorative pattern is necessary to transform to keep them be consistent with the aesthetic taste of modern people. Most Chinese traditional decorative patterns are more figurative and complex, so induction through simplification is the most direct way to change their shapes (Di, 2018). The design of the modern coffee table inspired by traditional Chinese lantern will easy and simple to decorate and present the traditional pattern.

#### 2.4 Material of Modern Coffee Table

The multi-plywood is using for the modern coffee table inspired by a traditional Chinese lantern. Multi-plywood, too known as three-layer board or three-layer plywood, which are a sort of board that we regularly utilize in furniture making. It is a Birch plywood type characterized by the great quality and solidness properties, and thus it performs exceptionally well in applications requesting tall quality and inflexibility. Besides, it has the preferences of great quality, lightweight, and amazing flexibility and durability. According to Bal and Bektaş (2014), plywood is one of the vital wood-based composites created from different tree species, and it has a few prevalent benefits compared to solid wood. It can resist splitting when nailed at the edges, limit extension and shrinkage and bump up its steadiness: suitable for the users to enjoy their tea life.

### 3. Research Methodology

#### 3.1 Questionnaire Survey

The respondents were those from the nuclear family which was the group family consist of two parents and their children. The questionnaire consisted of two parts which are demography information and design criteria of the coffee table. It will be based on the respondents to design the product. This survey would collect data from respondents which have 146 respondents to complete the questionnaire via a Google Form.

#### 3.2 Visual Research

Visual research is an observation that observed and searched online to find more ideas for the design. This visual research was to compare the difference of design pattern and the style to make a better idea into the design of the product.

#### 3.3 Thumbnail and Ideation

The design of thumbnail sketching was based on the questionnaire survey and visual research. Thumbnails and ideation were made by hand sketching to gain some basic idea. It was important in drawing and design that will influence until the final design. After the thumbnail, the ideation would be chosen from the thumbnail to set up the design concept.

### 3.4 Idea Development

The idea development was made from thumbnail and ideation sketching. It was the combination idea of thumbnail and ideation sketching. The idea development was made by hand sketching in three views of the design which are a top view, side view, and isometric view.

### 3.5 Design Selection

In this stage, the researcher was making the decision to select the idea development to the final design. The decision verified to be “Yes”, it would proceed to next stage which was final design while the decision verified to be “No”, it would return to the previous stage which is idea development. The researcher must be selected again for the design from idea development or drawing a new idea from the idea development sketching until the decision verified to be “Yes”.

### 3.6 Final Design

The final design was chosen by one of the idea development sketches. The researcher made the decision to select the best design from the design development in the final design of the product. The design was chosen in the idea development because it is the most convenient and storages compare with other idea development. Thus, the next stage was made the mock-up of the product.

### 3.7 Mock-up Development

The mock-up was built by using the impre board at a 1:5 scale from the actual size of the product. The mock-up was created from the final design. From the mock-up fabrication, the researcher would find out some problem in the design which was the dimension and angle of the design. The mock-up fabrication was making the researcher clear and understood for the weakness of the design.

### 3.8 Technical Drawing

The technical drawing was prepared before the prototype fabrication process. The AutoCAD software was used in technical drawing. The AutoCAD software can render the 3D modeling in three views which are a top view side view and isometric view. The rendering shows the actual color, size, dimension, and pattern of the coffee table.

### 3.9 Prototype Fabrication

The researcher finalized the actual size and the material selection of the product. Thus, the researcher started to produce the prototype of the design. The prototype was the completion of the design and made with multi-plywood and gluing with ICA Formica HPL sheets.

## 4. Results and Discussion

### 4.1 Questionnaire Analysis

In the questionnaire, 146 responses were collected from the nuclear family in Taman Indah Jaya, Teluk Intan to answer 9 questions through a Google Form. The questionnaire consisted of two parts which were Section A (demography information) and Section B (design criteria of the coffee table). Table 1 shows the demographic data and design criteria of modern coffee table inspired by traditional Chinese lanterns as most of the female respondents were 66.4%. The race of respondents was Chinese (68.5%) at age of 21-29 years old (37%). Thus, 48.6% of the respondents were employees in the Teluk Intan area.

In this study, the result shows that the most of respondents prefer the shape and color of the coffee table was a rectangle and natural color. The researcher made the prototype is using rubberwood as the

material of a modern coffee table inspired by a traditional Chinese lantern. Most of the respondents preferred the same as the standard height range which is 30cm-46cm. The traditional Chinese lantern pattern would design under the table and the style of the coffee table as to be lift top coffee table. In addition, the coffee table design required to add the storage to store items.

**Table 1: Example of presenting data using a table (Author, year)**

Section	Percentage (%)	Description
Demographic information	66.4	Female respondents
	68.5	Chinese respondents
	37.0	21-29 years old
	48.6	Employee
Design criteria of coffee table	66.4	Preferred coffee table made from rubberwood
	67.8	Preferred natural colour
	92.5	Agreed the coffee table with storage is more convenient and accessible location for storing items
	46.6	Select Style B – lift top style
	65.8	Preferred rectangle shape of coffee table
	70.5	Preferred same as standard height of coffee table
	95.9	Agreed the coffee table include storage
	70.5	Preferred pattern design beneath table
	56.2	Select Pattern 3 of the coffee table

#### 4.2 Visual Research

The researcher searches about the furniture with the traditional Chinese pattern and the style of coffee table from the website. Figure 1 shows that the visual research by the examples of furniture with the traditional Chinese pattern and the style of the coffee table.



**Figure 1: Visual research of coffee table**

#### 4.3 Thumbnail and ideation

Figure 2 shows that the thumbnail of the coffee table. Thumbnail sketching is based on the questionnaire survey which is lift top style, rectangle shape, and traditional Chinese pattern under the table. The rectangle in the blue color of the designs shown as thumbnail and ideation were chosen because the designs were unique and special compared with other designs.

#### 4.4 Thumbnail and ideation

Figure 2 shows that the thumbnail of the coffee table. Thumbnail sketching is based on the questionnaire survey which is lift top style, rectangle shape, and traditional Chinese pattern under the

table. The rectangle in the blue color of the designs shown as thumbnail and ideation were chosen because the designs were unique and special compared with other designs.

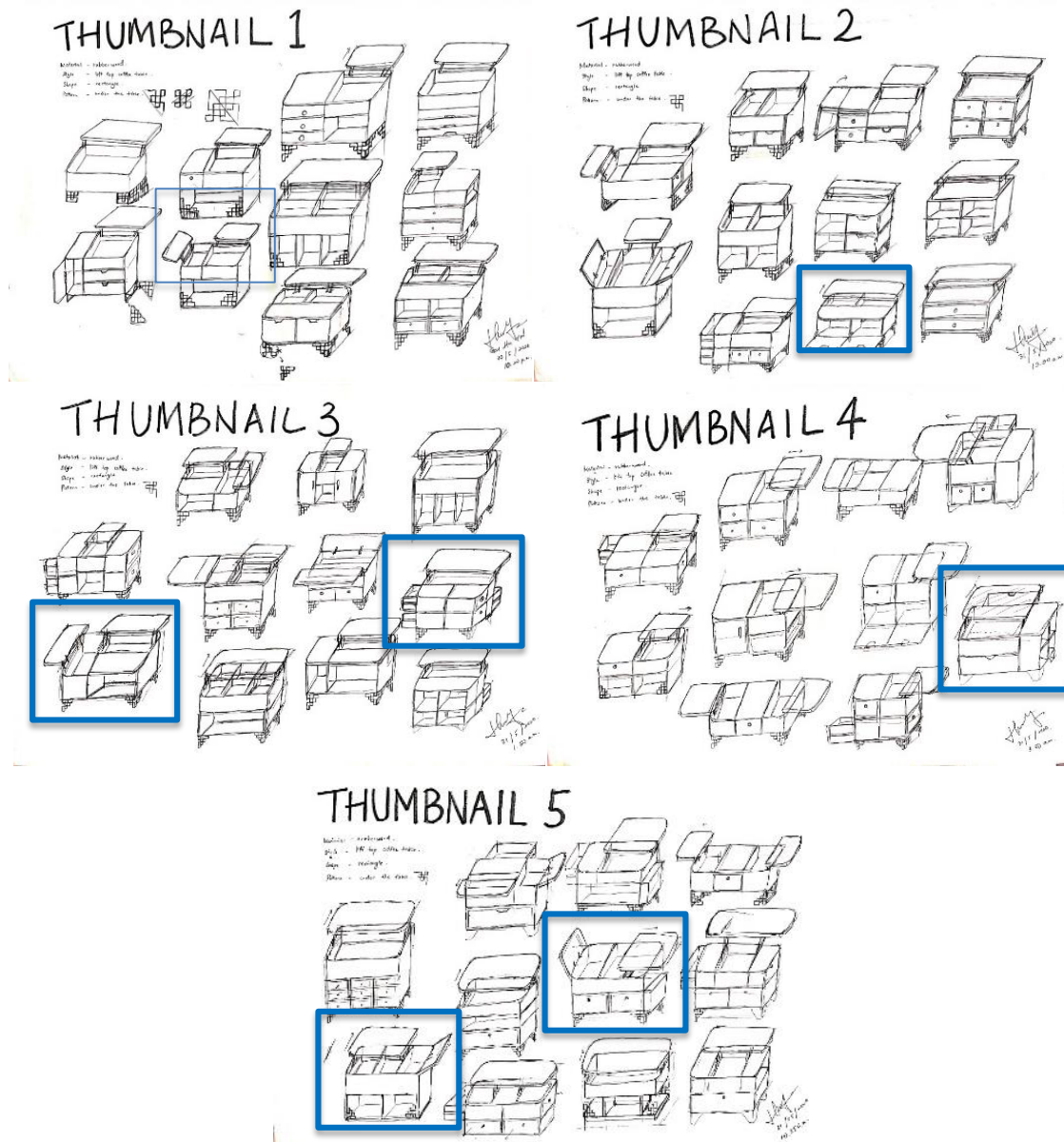

**Figure 2: Thumbnail of coffee table**

Figure 3 shows that the ideation of a modern coffee table inspired by a traditional Chinese lantern. The ideation has five pieces is selected from thumbnail sketching. There have different styles and patterns of the design based on the design criteria. The ideation is the improvement of the thumbnail sketches were selected due to the designs are different from the design of the market.

#### 4.5 Idea Development

Figure 4 shows that the idea development of a modern coffee table inspired by a traditional Chinese lantern. Each idea development represents three views of design which are an isometric view, front view, and side view. Each idea development represents three views of design which are an isometric view, front view, and side view.

There have 6 pieces of idea development include dimension and color. The length, height, and width of the entire idea development coffee table are 120cm, 45cm, and 60cm. The lift-top style coffee table

is used in my design with storage such as a multipurpose coffee table to convenience and fulfills the desire of users to drink Chinese tea using the tools of a tea set.

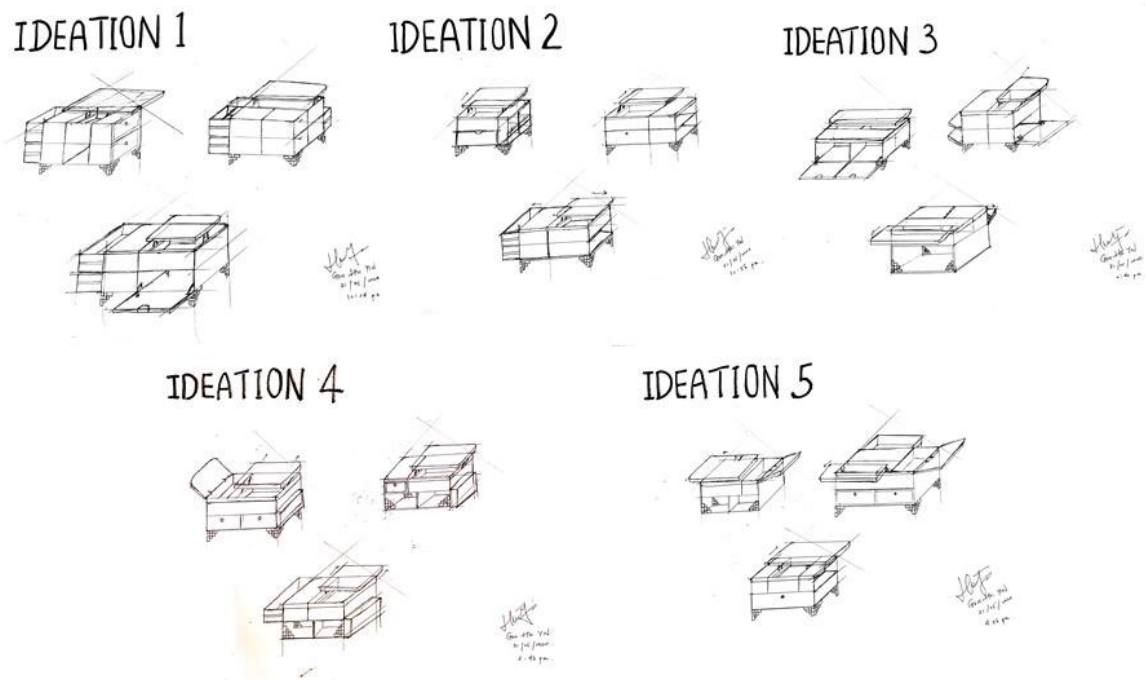

**Figure 3: Ideation of coffee table**

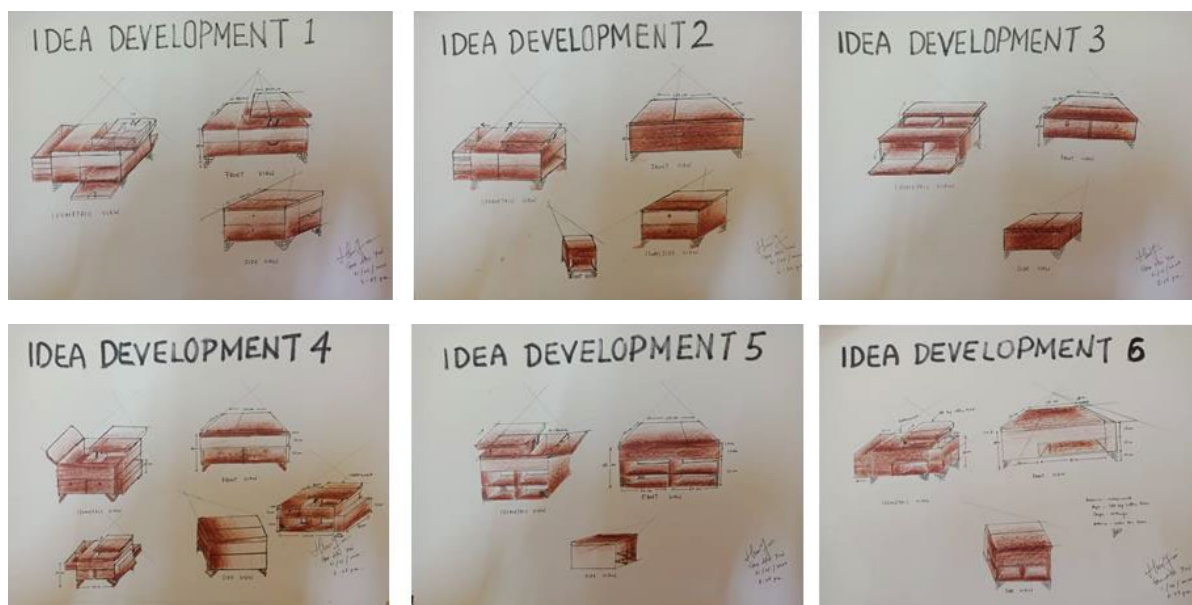

**Figure 4: Idea development of coffee table**

#### 4.6 Final Design

Figure 5 shows that the final design of the modern coffee table inspired by a traditional Chinese lantern. The modern coffee table inspired by the traditional Chinese lanterns is rectangular in shape and made of multi-plywood. The modern coffee table inspired by a traditional Chinese lantern with dimension and color selected from idea development 6. The final design is selected because the design ideas are more special, aesthetic, and innovative compared with other designs.

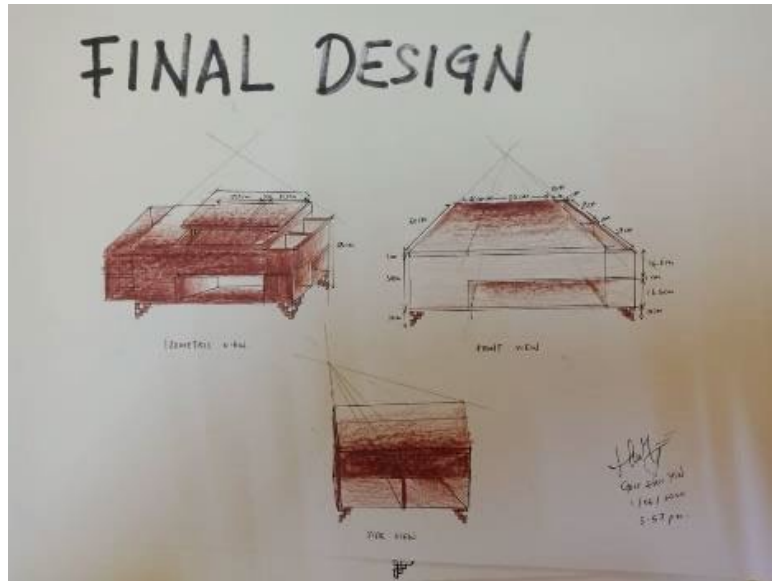

**Figure 5: Final design of coffee table**

#### 4.7 Mock-up Development

Figure 6 shows the mock-up of a modern coffee table inspired by a traditional Chinese lantern. The materials were using the hot glue gun, blade, impre board, pen, and ruler for mock-up of modern coffee table inspired by a traditional Chinese lantern.

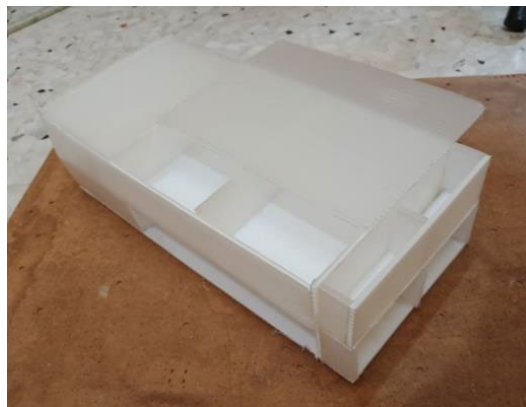

**Figure 6: Mock-up of modern coffee table inspired by traditional Chinese lantern**

#### 4.8 Technical Drawing

Figure 7 shows that the views of 2D drawing in the technical drawing which are a front view, right view, top view, and isometric view. The 2D technical drawing is included the dimension using by Autodesk AutoCAD design software.

#### 4.9 Prototype Fabrication

Figure 8 shows that the finished prototype made of multi plywood and laminated with ICA Formica. The materials including the Lifting Frame Gas Hydraulic Hinges, laminated plastic adhesive, table saw machine, multi plywood, try square, pencil, High-Pressure Laminates (HPL) sheet, sanding paper, gluing, screws, drawer slide, steel measuring tape, electric drill, bar clamp, jigsaw, finish nails and gauge straight finish nailer in the manufacturing process.

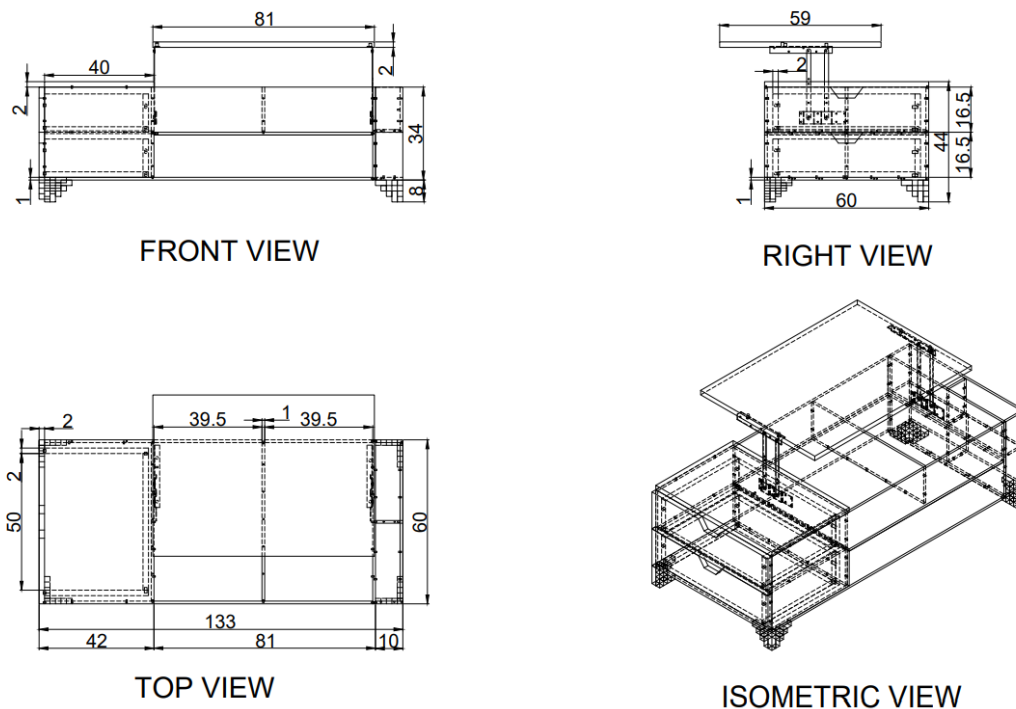

**Figure 7: 2D drawing of the modern coffee table inspired by traditional Chinese lantern**

Multi-plywood is sawing by using a table saw machine that measured from the dimension for the process of sawing. After the process of sawing, the coffee table legs measure using by pencil and sawing by jigsaw. For the process of drilling, the drawer slide fixed on the multi-plywood drilled by an electric drill. The drilling process is vital in providing stability to the coffee table while drilling all-around by screw after gluing and assembly process.



**Figure 8: Prototype of modern coffee table inspired by traditional Chinese lantern**

Before the process of assembly, the sawed multi-plywood would be gluing using adhesive glue with other sawed multi-plywood. Thus, the sawed multi-plywood nailed by gauge straight finish nailer to fix and stable in the specific place based on the final design. For the gluing process, the surface of the product would be gluing through laminated plastic adhesive toward the high-pressure laminates (HPL) sheet. Hence, flatten the surface of the product after gluing to make it smooth and steady using by wood chip. The completed coffee table legs are gluing and nailing before assembling for the body of the modern coffee table. The modern coffee table inspired by traditional Chinese lanterns was finished successfully.

## 5. Conclusion

In conclusion, the design criteria of modern coffee table inspired by traditional Chinese lantern were rectangle in shape, lift top coffee table in style, the pattern of traditional Chinese lantern under the coffee table, made by multi-plywood and neutral color of the design. In this study, 5 pieces of the thumbnails and ideations, 6 pieces of idea developments were sketched; final design was chosen by idea development 6 and manufactured into the prototype. The prototype was made by multi-plywood although the questionnaire results represent that the wood material used in rubberwood for the prototype from the respondents. The multi-plywood always used in home improvement and in modern decoration. It is because the multi-plywood consisted of lightweight, good quality, toughness, and excellent elasticity for the furniture manufacture materials.

The first objective was to identify the characteristics of a coffee table that apply the elements of the Chinese style in the designing patterns. Among the study, the prototype revealed unique designs including the modern and the traditional Chinese style. It was distinct in the living room to users who like to drink Chinese tea using the tools of the tea set. The next objective of a modern coffee table inspired by a traditional Chinese lantern was going to store the pile of sundries and tea sets. The prototype of the modern coffee table was completed successfully based on the final design. It was very convenient to keep the things which are remote control, letter, newspapers and so on into the storage of the coffee table.

The width the wood sheet of technical drawing 2D & 3D and prototype were different which the dimension was 1 or 2 cm and 1.8cm. Therefore, the width of the entire multi-plywood was 1.8cm in dimension. To develop a prototype of a modern coffee table in the living room was the objective of the coffee table. The prototype of a modern coffee table inspired by a traditional Chinese lantern was developed completely made by multi-plywood and gluing with ICA high pressure laminated (HPL) sheet. Through this study, there is some recommendation to improve the design of the prototype. The rectangle shape of the prototype occupied more space so that unsuitable for the small living room. Thus, the four edges of the coffee table are very dangerous for children. Hence, the over or circle shape has been suggested to reduce the harm to the users and children.

## Acknowledgement

This research was made possible by support from the Faculty of Technology Management and Business, Universiti Tun Hussein Onn Malaysia.

## References

- An, Z., Wang, K., W., & Lv, P. (2017). The value of Chinese traditional culture and its influence on moral education in Colleges and Universities. 123(Icesame), 1741–1744. <https://doi.org/10.2991/icesame-17.2017.370>
- Aryal, S. (2020, January 14). Questionnaire method of data collection. Retrieved from <https://microbenotes.com/questionnaire-method-of-data-collection/>
- Bal, B. C., & Bektaş, İbrahim. (2014). Some mechanical properties of plywood produced from eucalyptus, beech, and poplar veneer. *Maderas: Ciencia y Tecnología*, 16(1), 99–108. <https://doi.org/10.4067/S0718-221X2014005000009>
- Deason, R. (2018, January 25). A brief history of chinese lanterns. Retrieved from
- Deng, M. (2017, Feb 5). Living room and dining room storage magic- The relationship between people and things. Retrieved from <http://jjiaju.sina.cn/news/j/20170502/6265112283144586231.shtml>
- Di, W. (2018). Research on the Application of Chinese Traditional Cultural Elements in Modern Furniture Design. *Journal of Advanced Oxidation Technologies*, 21(2), 300–303. <https://doi.org/10.26802/jaots.2018.09123>
- Dunnett, H.M. (1951) 'Furniture since the War', *Architectural Review*, March: 150- 67.
- Edward H. Johnson, 9761 E. Pinnacle Vista Dr., Scottsdale, A. 85255. Combination multiple ottomans and coffee table and mehod therefor. U.S. Patent 6,045,193. 2000.

- Fantastic Offense (2019, November 1). Coffee-accent tables. Retrieved from <https://www.dimensions.guide/collection/coffee-tables-accent-tables>
- Gignac, M. (2020). Everything you need to know about coffee tables. Retrieved from <https://www.yammagazine.com/coffee-tables-buy-design-victoria/>
- Hasirci, D., &Tuna Ultav, Z. (2019). Mid-Century Modern Furniture Representing Modern Ideals in the Grand National Assembly of Turkey. *Journal of Interior Design*, 1–23. <https://doi.org/10.1111/joid.12160>
- Li, H., Liu, W., &Li, X. (2016). Construction of Basic-element Database for Traditional Chinese Culture in Industrial Design. *Procedia Computer Science*, 91(Itqm), 1011–1017. <https://doi.org/10.1016/j.procs.2016.07.137>
- Saruwono, M., Zulkiflin, N. F., &Mohammad, N. M. N. (2012). Living in Living Rooms: Furniture Arrangement in Apartment-Type Family Housing. *Procedia - Social and Behavioral Sciences*, 50(July), 909–919. <https://doi.org/10.1016/j.sbspro.2012.08.092>
- Wang, Z. Q. (2018). Brokenness' and "establishment": Design and innovation of traditional Chinese lanterns of Gannan Hakka's Area. *Proceedings of the 2017 IEEE International Conference on Information, Communication and Engineering: Information and Innovation for Modern Technology, ICICE 2017*, 155–158. <https://doi.org/10.1109/ICICE.2017.8478897>
- Wheat, J and Indianapolis, Furniture accessory storage system and method. 1. U.S. Patent US 2018 / 0035817 A1. 2018.