

## Design of Feeding System in Recycle Vending Machine (RVM)

Nur Nabilah Huda Abdul Shukor<sup>1</sup>, Abdul Khalil Abdul Rahim<sup>1,\*</sup>

<sup>1</sup>Faculty of Mechanical and Manufacturing Engineering,  
Universiti Tun Hussein Onn Malaysia, Batu Pahat, 86400, MALAYSIA

\*Corresponding Author Designation

DOI: <https://doi.org/10.30880/rpmme.2023.04.02.007>

Received 25 Aug 2023; Accepted 25 Oct 2023; Available online 15 December 2023

**Abstract:** A recycling machine, also called a "reverse vending machine," is a machine that accepts used or empty glass bottles, plastic bottles, or aluminium in exchange for a reward. After recycling materials are inserted, they are compressed, sorted, and evaluated. After the object has been scanned and confirmed, it is crushed and placed in the appropriate storage area for classified materials. The machine provides incentives, such as cash or coupons, after processing the item. This project's purpose is to provide a comprehensive feeding system for receiving and sorting recyclables in a recycle vending machine (RVM). This project used George E Dieter design process for design this machine. The design process consists of eight phase which are Define problem, Gather information, Concept generation, Concept evaluation, Product architecture, Configuration design, Parametric design and Detail design. The existing patent and available machine were referred to generate idea for the banana slicing machine. The selected idea and concept then will be modelled using Solidwork Software. Solidwork Software also being used to conduct some engineering analysis. The author also making analysis using theoretical calculation. The result of the analysis shows that the machine can feed 5s per unit. The overall dimension of the Feeding system is 1522mm x 806mm x 350mm with the weight of 26.64 kilogram.

**Keywords:** Recycle Vending Machine (RVM), Feeding System

### 1. Introduction

People's intelligence is increasing with time, the countless elements, technologies, and inventions that have been developed have resulted in a global revolution. Plastic, aluminium cans and paper are the most commonly encountered materials in our daily lives. Plastic is a popular material due to its versatility and low cost of production [1]. Plastic production has expanded quickly during the 1950s and continues to do so, according to the Our World in Data website. In 2019, global plastic manufacturing exceeded 400 million tonnes per year [2]. While 1.9 million tonnes of aluminium are produced each year to make container and packaging material, and approximately 1 billion trees worth of paper are discarded in the United States each year. Nevertheless, each year, Americans use 85 million tonnes of paper [3].

---

\*Corresponding author: [khalil@uthm.edu.my](mailto:khalil@uthm.edu.my)

2023 UTHM Publisher. All right reserved.

[penerbit.uthm.edu.my/Periodicals/index.php/rpmme](http://penerbit.uthm.edu.my/Periodicals/index.php/rpmme)

As a result, massive amounts of waste end up in the oceans, rivers, and landfills. Recycling is considered as the most effective way to protect the earth's environment. By reusing materials instead of discarding them, we can both reduce the amount of waste and preserve future natural resources. Thus, landfill waste will be reduced, while also reducing water and air pollution. Recycling solid waste provides environmental and health benefits in as well as economic benefits [4].

## 2. Review of literatures

### 2.1. Study of Feeding System in RVM

The recyclables are put into the RVM through the feeder, which is a part of the device. The feeder is the primary and most important component for sorting recycled materials by category. It also has a weighing mechanism for measuring the weight of recycled paper materials. This makes the feeder one of the most significant components. After the various types of recyclables have been sorted into their appropriate categories, the conveyer will transport them to the next level of processing. The flow process is depicted in more detail in the diagram that follows.

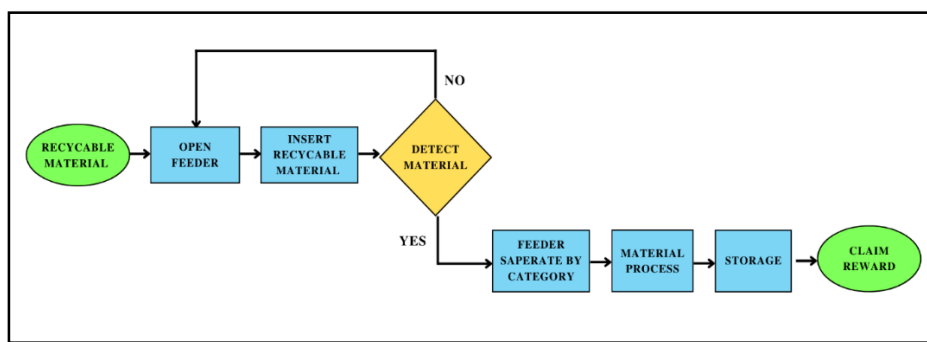







Figure 1: Flow Process of Feeding System in RPM

### 2.2. Study of Existing Product

Available product is an existing product that is currently being sold on the market. Existing product search is important because it gives you a lot of information to review or search over, such as product features and specifications. All the information will be used to generate new, innovative ideas for the design of a brand-new feeding system product in RVM. The table below compares a few RVMs that are already on the market.

Table 1: Existing Product Comparison

Product Detail					
Brand Model	DIGI DRV-200	ACO K-3/7500	Tomra T90	RVM X2	EcoVend RVM100
Origin	Japan	Turkey	France	Scandinavian	United Kingdom
Dimension (L x W x H) mm	1090 x 800x 1170	1250 x 1410 x 2000	1870 x 1454 x 1773	78 x 90 x 184	1850 x 650 x 950
Weight (Kg)	260	550	525	NA	350
Productivity	15 unit/min	40 Units/min	45 Unit/min	50 Unit/min	15 Unit/min

Acceptance item	PET plastic bottles	Plastic, aluminium & glass bottles	Plastic, aluminium & glass bottles	Plastic & aluminium bottles	Plastic & aluminium bottles
Acceptance size	150 ml to 2L	150 ml to 3L	150 ml to 2L	150 ml	150 ml to 3 L
Operating power (voltage)	100 V	380 V	400V	230 V	230 V
Material recognition	<ul style="list-style-type: none"> <li>• Combination of camera and sensors inputs</li> </ul>	<ul style="list-style-type: none"> <li>• Photo recognition</li> <li>• 360-degree recognition</li> <li>• Barcode recognition</li> <li>• Weight recognition</li> </ul>	<ul style="list-style-type: none"> <li>• 360° instant recognition</li> <li>• shape recognition</li> <li>• full container detection</li> <li>• Barcode recognition</li> <li>• Metal detection</li> </ul>	<ul style="list-style-type: none"> <li>• 360-degree barcode reading,</li> <li>• metal detection,</li> <li>• shape recognition</li> <li>• weight recognition</li> </ul>	<ul style="list-style-type: none"> <li>• Barcode recognition</li> <li>• material sensors</li> <li>• weight sensors</li> </ul>
Transmission	Gravity	V- conveyer	V- conveyer	V- conveyer	V- conveyer

### 3. Methods of approach

The project will be carried out using George E. Dieter's model of the design process. According to George E. Dieter, there are three phases and eight stages in the design process. The conceptual design comes first, followed by the embodiment design, and finally the detail design. Defining the problem, acquiring information, producing concepts, and assessing those concepts are the processes that make up the overall process of conceptual design. Product architecture, configuration design, and parametric design are the next stages of the embodiment design process. The detail design will be the final stage in this model of the design process. The figure below depicts the project's flowchart.

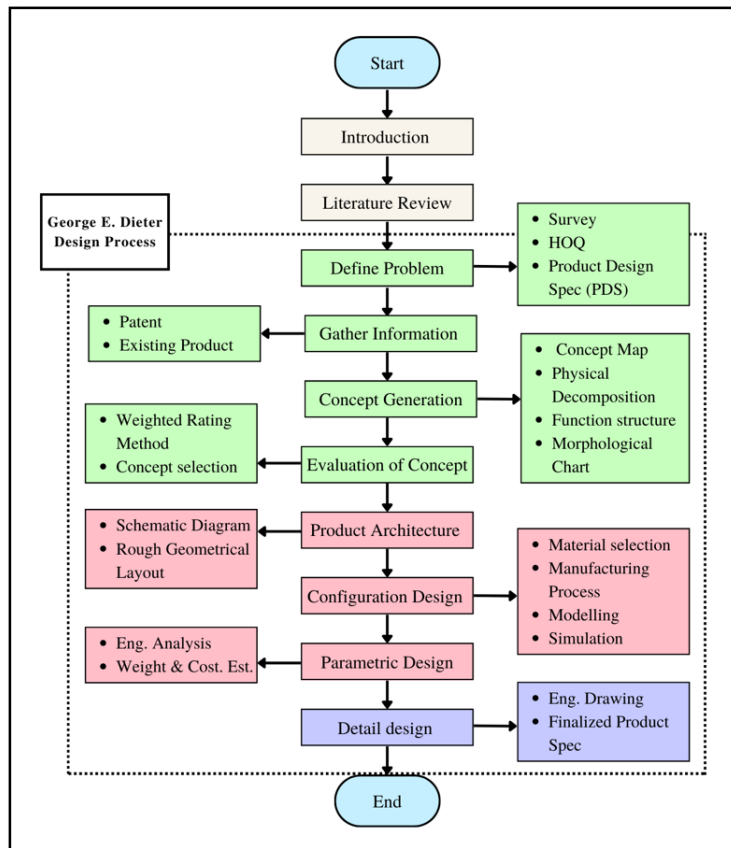

Figure 2: Flowchart of Design Process

#### 4. Design Process

##### 4.1. Product Design Specification

The survey is conducted through a questionnaire in order to collect information. There are four sections within the questionnaire. consist of general information, recycling behaviors, product specifications, and product outcomes. The information gathered from the consumer survey will be used to generate the objective tree and the Product Design Specifications (PDS). Figure 3 and table 2 depict the Objective tree and product design specification, respectively.

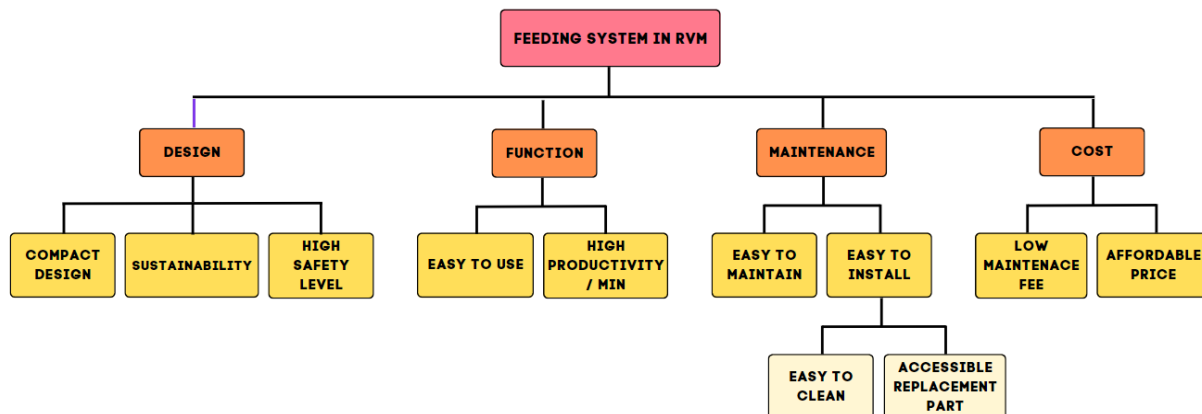

Figure 3: Objective Tree of Feeding System In RVM

**Table 2: Product Design Specification**

<b>Title: The Design of Feeding System in RVM</b>	
<b>Introduction</b>	
Design problem	: To design feeding system that received and separate four recyclable materials
Intended purpose	: Design a suitable route and system for delivering four recyclable materials to the next process in RVM.
Special features	: To design a feeding system adding paper as a recycling material in the RVM
<b>Customer Requirements</b>	
	D or W
<b>Functional performance</b> <ul style="list-style-type: none"> <li>• Able to separate four materials following their category</li> <li>• High productivity per minute</li> <li>• Can withstand the load maximum up to 3kg recyclable material</li> </ul>	D D D
<b>Maintenance</b> <ul style="list-style-type: none"> <li>• Design must be simple and easy to perform maintenance and cleaning</li> <li>• Low maintenance cost</li> <li>• Easy to find spare part / replacement part</li> <li>• Easy to remove and reinstall the component (conveyor)</li> </ul>	D D W D
<b>Design</b> <ul style="list-style-type: none"> <li>• Position or height of inlet chute for user to use RVM should be ergonomic</li> <li>• The design must be intuitive and simple to use</li> <li>• Combination of equipment does not require a large space</li> <li>• The design meets at least minimum 10 years life time</li> </ul>	D W W D
<b>Safety</b> <ul style="list-style-type: none"> <li>• Rejection system by using sensor and pneumatic arm to avoid wrong material separate in wrong category</li> </ul>	D

## 4.2. Concept Generation

Innovative products often result from combining effective design principles and identifying creative ideas from diverse categories. [5] Techniques like brainstorming are practical methods for generating design concepts that enhance creativity. In this phase, concept generation involves various approaches such as mapping concepts, functional and physical decomposition, function structure, and morphological chart. The function structure of a Feeding System in RVM is depicted in Figure 4, illustrating its key components and their interconnections.

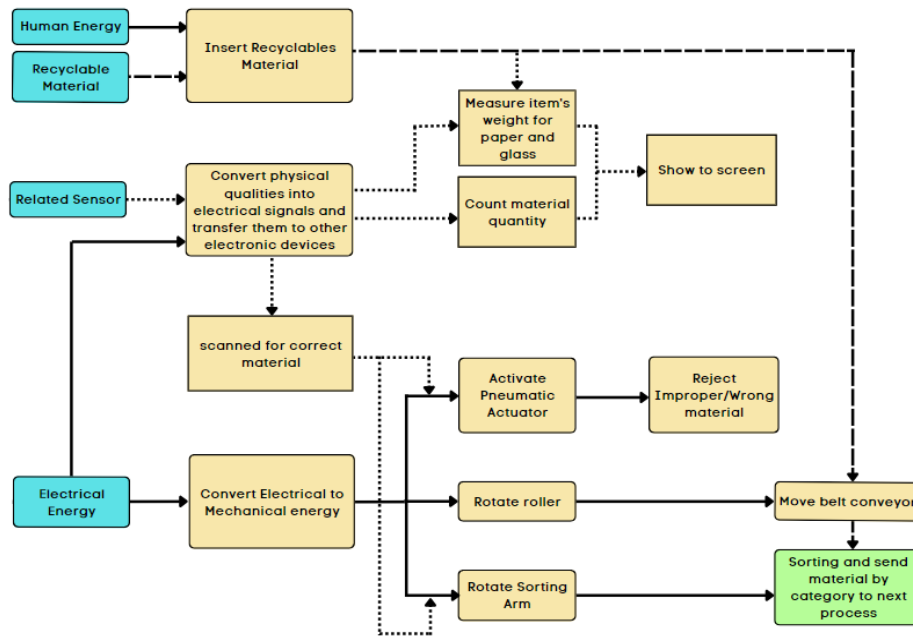

Figure 4: Function Structure of Feeding System in RVM

### 4.3. Concept Evaluation and Concept Selection

From a morphological chart, a weighted decision matrix was utilized to examine and evaluate a variety of concepts by ranking the design criteria with a weighting factor derived from the objective tree questionnaire. This method enabled the designer to identify the concepts that best meet the basic customer requirements. After evaluating each concept, the concept with the highest rating will advance to the next phase. The concept selection for the machine is displayed in Table 3.

Table 3: concept selection of the machine

No	Function	Alternative
1	Convert electrical to mechanical energy	Electric motor
2	Move conveyor belt	Roller
3	Rotate roller	Dc motor
4	Measure item's weight	Beam load cell
5	Scanned correct material	Through beam sensor
6	Active pneumatic actuator	Ultrasonic sensor
7	Reject improper material	Linear arm sorter
8	Rotate sorting arm	Servo motor
9	Sort and send material by its category	slides

### 4.4. Product Architecture

Product architecture is the arrangement of a product's tangible components to fulfil its intended purpose. It was affiliated with the function structure. Once a design concept has been chosen, it is chosen to maximise the system's functional success. The architecture of products included the Schematic and Geometric layout of the product. Figures 5 and 6 depict, respectively, the schematic product and geometric layout.

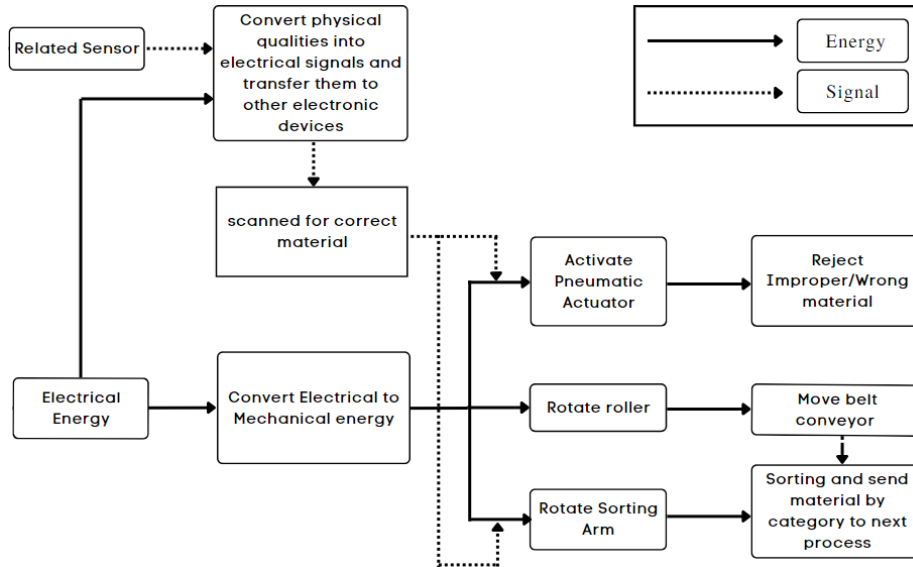

Figure 5: Product Schematic

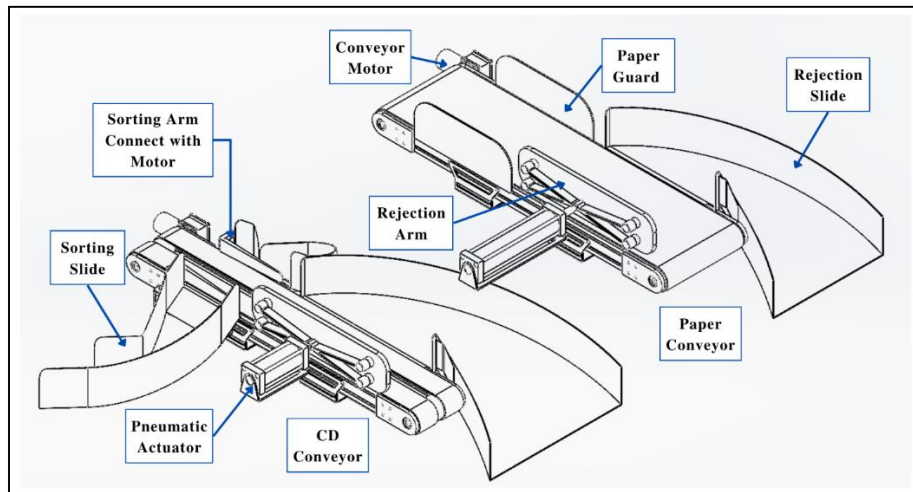

Figure 6: Geometric layout

#### 4.5. Modelling

Concept of Feeding System in RVM was drawn by using Solidwork. All component that are drawn will be assembled to form the overall structure of the product. Figure 7 below shows the full assembly of the product.

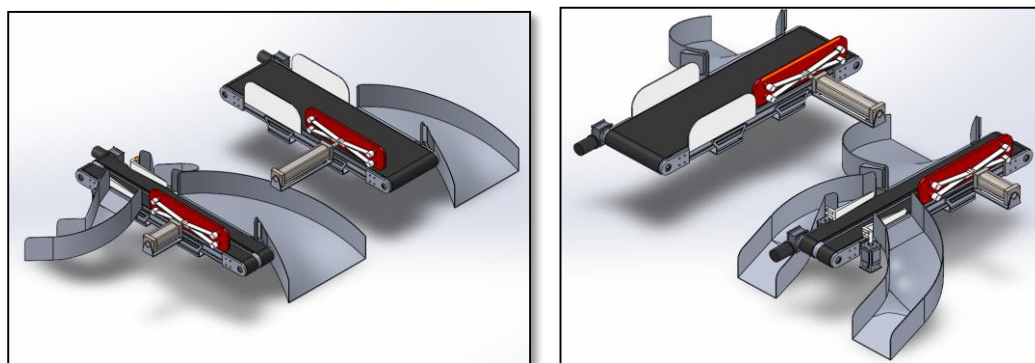

Figure 7: Full Assembly of Feeding System in RVM (a) Frontside (b) Backside

#### 4.6. Machine Process Flow

The roller of conveyor attached to geared motor that drive the conveyor belt. When motor rotates in a



clockwise direction, the belt moves accordingly. The figure below shows the relationship between motor, idler roller and conveyor belt.

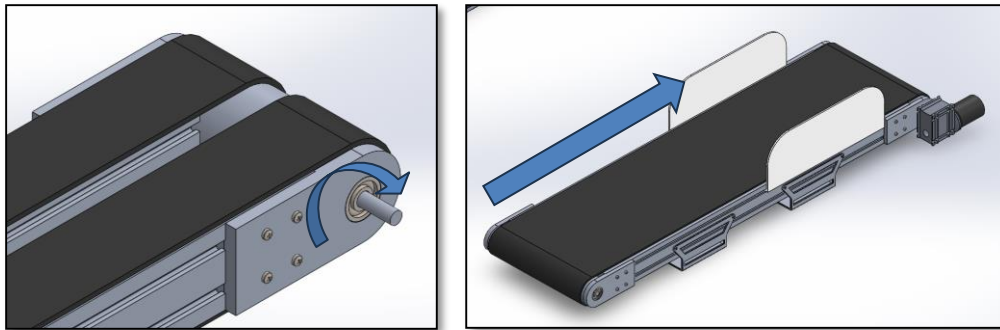

**Figure 8: Conveyor Movement**

While the material travel using conveyor, a sensor will detect either it is a right material as chosen on the screen. If it is not tally, it will reject the material by using pneumatic actuator that connect with rejection arm. If it is a correct material, for circular dimension material like glass, cans and plastic bottle, it will go to sorting section. Table below shows the motion for better understanding.

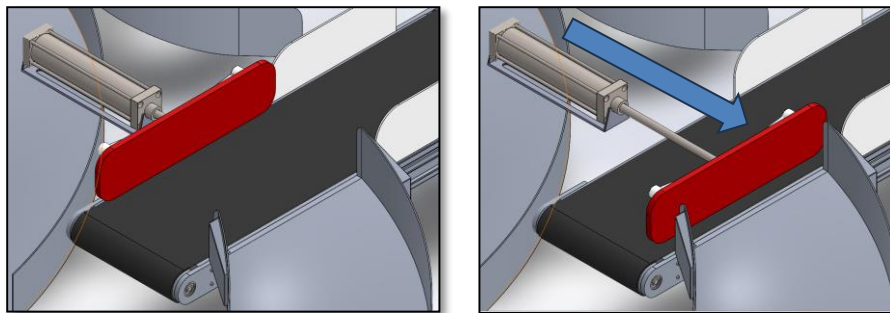

**Figure 9: Rejection Arm Motion**

In the sorting section, the material will be scanned to activate the servo motor by rotating the sorting arm 40 degrees from its initial position. This rotation is intended to position the sorting arm so that it can drive the material towards the sorting slide effectively. Now positioned at the desired angle, the sorting arm provides a pushing force on the material to direct it towards the sorting slide. The sorting slide is designed to receive and guide the material to their subsequent operation or designated area for further processing.

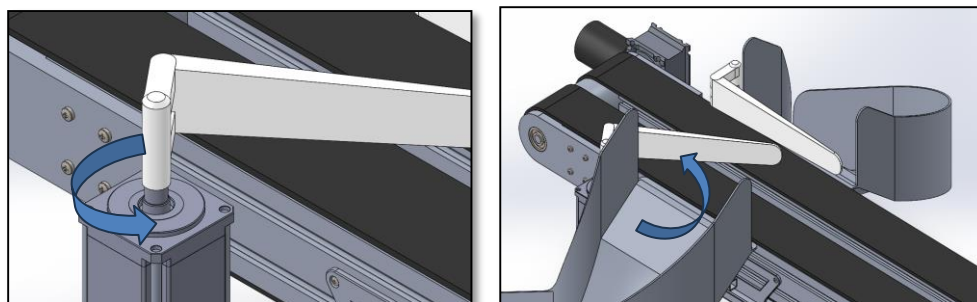

**Figure 10: Sorting Arm Motion**

#### 4.7. Engineering Analysis

The analysis calculated torque, power, and speed of belt. Calculations assist select a component that will not fail and reduce product cost. Analysis creates product design specifications. Table below shows final product design specification.



**Table 4: Final Product Design Specification**

Product specification	Description
Product weight	26.264 kg
Dimension ( $L \times W \times H$ )	(1.522 × 0.806 × 0.350) m
Geared Motor Power Output	60 W
Belt speed	0.00159 m/s
Servo motor Power Output	100 W
Pneumatic actuator pressure	0.1 – 0.9 Mpa
Max load capacity	5 kg
Price	RM 11 279.49

#### 4.8. Simulation Analysis

There are three critical point in Feeding System in RVM which is idler roller, rejection slide, and sorting arm. Analysis of stress, strain and displacement in solidwork is important for determining structural integrity, evaluating performance, selecting materials, predicting failure, improving designs, and ensuring compliance with standards and regulations.

##### Idler roller Analysis (Torque = 0.49Nm)

Stress (Von Mises)	Displacement	Strain
1) $Max = 0.127 MPa$	1) $Max = 7.789 (10^{-5}) mm$	1) $Max = 1.207 (10^{-6})$
2) $Min = 1.768 (10^{-15}) Pa$	2) $Min = 1.000(10^{-30}) mm$	2) $Min = 0.00$

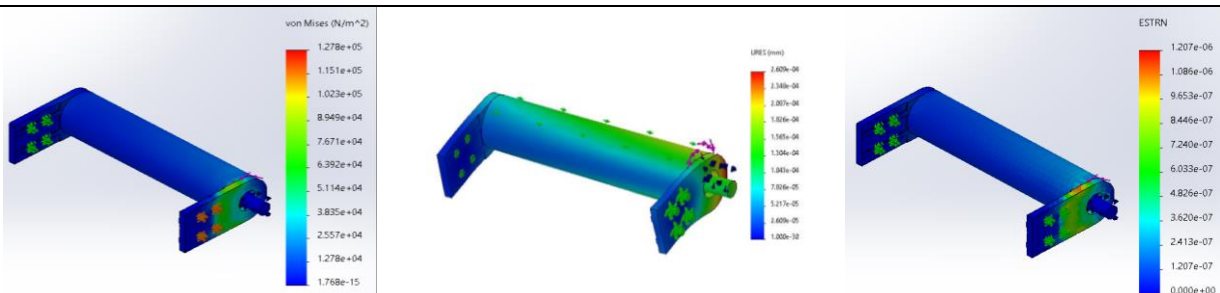

##### Rejection slide (Distribution load 5kg)

Stress (Von Mises)	Displacement	Strain
1) $Max = 1.676 MPa$	1) $Max = 3.273 (10^{-2}) mm$	1) $Max = 1.331 (10^{-5})$
2) $Min = 23.25 Pa$	2) $Min = 1.000(10^{-30}) mm$	2) $Min = 5.721 (10^{-10})$

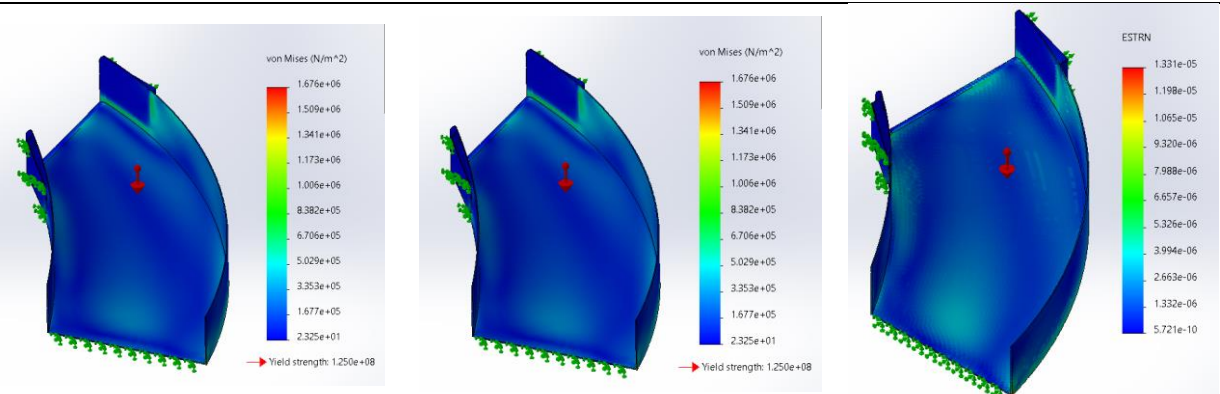

##### Sorting Arm Analysis (Distribution Load 5 Kg & Torque 10.4 Nm)

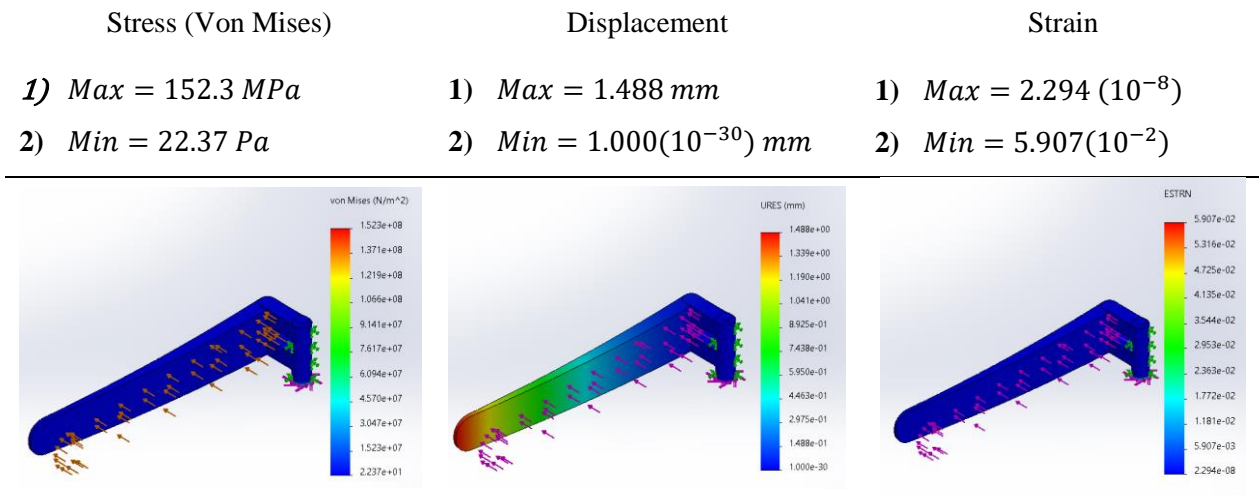

Figure 11: Critical point of feeding system in RVM

## 5. Conclusion

In conclusion, the design method for the Feeding System in RVM is based on George E. Dieter's methodology. To design an improvised feeding system for receiving and separating recyclable materials in a Recycle Vending Machine (RVM) has been accomplished. The machine's purpose is to receive, categorize, and convey four recyclable materials to the subsequent process. Using SolidWorks, machine components have been designed, analyzed, and engineering drawings have been generated. The final machine design is capable of supporting operations at 0.00159m/s and 609 revolutions per minute. The machine weighs 26.26kg and measures 1.522 m in length, 0.806 m in width, and 0.35 m in height. The product can support up to 5 kg of recyclable materials. It is anticipated that the product will be more effective in assisting students or societies in achieving environmental sustainability and will contribute to a healthier and more prosperous future.

## Acknowledgement

The authors wish to thank to the Faculty of Mechanical and Manufacturing Engineering, Universiti Tun Hussein Onn Malaysia that has supported on the accomplishment of research activity.

## References

- [1] J. Lim, Y. Ahn and J. Kim, Optimal sorting and recycling of plastic waste as a renewable energy resource considering economic feasibility environmental pollution, Process Safety and Environmental Protection, (2022).
- [2] Global plastics production. (2015). Our World in Data. <https://ourworldindata.org/grapher/global-plastics-production> .
- [3] US EPA, OSWER, ORCR, RCSD. (2018, July 30). Aluminum: Material-Specific Data | US EPA. US EPA. <https://www.epa.gov/facts-and-figures-about-materials-waste-and-recycling/aluminum-material-specific-data>.
- [4] L. Walid, O. Asanousi. The Impact of Recycling in Preserving the Environment Discussing the Waste Management Expectations of the Future View Project Waste Disposal and Landfill Potential Hazards and Their Impact on Groundwater View Project. researchgate, 12 Dec. 2021.

- [5] Bernama. (2022, March 10). Can Malaysia achieve 40 per cent recycling rate by 2025? New Straits Times. Retrieved December 1, 2022, from <https://www.nst.com.my/news/nation/2022/03/778625/can-malaysia-achieve-40-cent-recycling-rate-2025>
- [6] E. Schulze, Colo. 80010, & Fulton. (1992, May 12). US5111927A - Automated recycling machine - Google Patents. US5111927A - Automated Recycling Machine - Google Patents. Retrieved January 9, 2023, from <https://patents.google.com/patent/US5111927A/en>.
- [7] Morishita, Lee, Chung, & NJ. (2014, October 7). Reverse Vending Machine. Google Patent. <https://patentimages.storage.googleapis.com/09/5d/d2/e8d52618667ed2/US8851265.pdf>.
- [8] Krishnamurthy, PA, Rastogi, A. Rock, Sreenath, A. Yhap, CO, Cook, & Sharma. (2040, July 1). US11104512B2 - Automatic sorting of waste - Google Patents. US11104512B2 - Automatic Sorting of Waste - Google Patents. <https://patents.google.com/patent/US11104512B2/en>.
- [9] M. Hannawa, & Sheena. (2012, October 29). US10210693B2 - Reverse vending machine incorporating a method of cleaning therein - Google Patents. US10210693B2 - Reverse Vending Machine Incorporating a Method of Cleaning Therein - Google Patents. <https://patents.google.com/patent/US10210693B2/ja>.
- [10] M. Kiva, R. Aldrich, & A. Coyne. (2001, May 9). US20030010598A1 - Recycling machine with container compacting system - Google Patents. US20030010598A1 - Recycling Machine with Container Compacting System - Google Patents. <https://patents.google.com/patent/US20030010598>.