

Analysis and Design of Reinforced Concrete Flat Slab Subjected to Line Load

Ng Yao Xin Saeralyn^{1,*}, Heng Boon Koh^{1,*}

¹Faculty of Civil Engineering and Built Environment,
Universiti Tun Hussein Onn Malaysia, Parit Raja, Batu Pahat, 86400, MALAYSIA

*Corresponding Author Designation

DOI: <https://doi.org/10.30880/rtcebe.2021.02.01.031>

Received 30 January 2021; Accepted 28 April 2021; Available online 30 June 2021

Abstract: Reinforced concrete flat slab has been used since the early twentieth century and are often applied in residential, offices and similar buildings constructions as they are practical and reasonably affordable to build. Load failures can affect the structure that cause the collapsing of the building due to critical moment transfer at the slab-column connection. However, there is a dearth of previous studies on standard instructions and guidelines for designing flat slabs when subjected to line loads design as the coefficient given in the standard design codes is mainly for the slab subjected to bending moment only. Line load due to permanent brick wall applied on the flat slab is often ignored by the designer. Therefore, this study has been carried out to produce the design table for reinforced concrete flat slab subjected to UDL, and to study the structural behaviour of the flat slab subjected to line load. This is a comparative study. Structural analysis and design software were used to analyse the flat slabs. Eurocode 2 (EC2) has been used to analyse and design the reinforced concrete flat slab. Data obtained from the ESTEEM software were input into Excel Spreadsheet to develop the design table for reinforced concrete flat slab subjected to uniformly distributed load. The ESTEEM software was used to investigate the structural behaviour of the flat slab subjected to line load. The overall result of this research indicates that the dimensions and loadings on flat slabs are significantly related with the behaviour of the structures.

Keywords: Reinforced Concrete, Flat Slabs, Line Load, Structural Behaviour

1. Introduction

Reinforced concrete flat slab supported merely by the slab-column connection has been used since the early twentieth century and are often applied in residential, offices and similar buildings constructions as they are practical and reasonably affordable to build [1]. Load failures can affect the structure that cause the collapsing of the building due to critical moment transfer at the slab-column connection [2-4]. Researches pointed out that line loading sustained by slab structure often causes excessive crack widths that eventually lead to durability, tightness or even aesthetics failures and the requirements that were provided for nominal slab structures in design standards are mostly on crack control and width limits; overlooking the partition wall that is arranged on the slab acting as a line load

*Corresponding author: koh@uthm.edu.my

2021 UTHM Publisher. All rights reserved.

publisher.uthm.edu.my/periodicals/index.php/rtcebe

that may affect the structural behaviour of the slab [5]. However, there is still a dearth of previous studies on standard instructions and guidelines for designing flat slabs when subjected to line loads as most of the coefficients given in standard design codes, for example American Concrete Institute (ACI 318), Australian Concrete Structures Standard (AS3600), Eurocode 2 (EC2), and British Standards (BS) are only provided with uniformly distributed load (UDL) and simplified bending moment distribution only.

Therefore, this study has been carried out to design a table for typical span based on UDL and to evaluate the behaviour of flat slabs around the column and the middle strips when they are subjected to line load.

Moreover, Subramaniam [6] claimed that reinforced concrete flat slab is widely used as it provides a simpler formwork and reinforcement layout, speedy construction and its cost is lower in terms of labour works especially for constructions of symmetrical structures such as warehouses, parking lots and industrial buildings as it does not require much concrete while at the same time providing greater reinforcement than would be required for the nominal flat plates with the same loads and spans. However, with the absence of beams in the structure, the moment transfer between the slab and column can be more critical as it must resist larger horizontal loads [7]. Besides the nominal flat slabs, flat slabs with drop panels or columns heads are introduced to reduce the shear failure at columns [8].

Line loads are the loads distributed uniformly over a relatively narrow location when the widths are less than one-third of the radius of relative strength of the slab [9].

Flat slab was calculated by using the direct design method (DDM) that based on manual calculations, and the equivalent frame method (EFM) that uses digital computers together with non-linear analysis. However, for both methods, the column strips were the slab located on each side of the column centre line ranging between $0.25L_2$ and $0.25L_1$, while on each opposite sides of the column strips were the middle strips [6]. When using the direct design method, the flat slab designed should have three spans or more in each direction, with the length of the longer span to be more than two-third of the adjoining span. Besides, the ratio of long span to short span shall be two or less than two and the columns must be closer to the corners of every panel. The live loads on the slab should not exceed three times of the dead loads [7].

The finite element method is a powerful numerical technique used to model experimental data to examine the behaviour of reinforced and prestressed concrete [10]. According to Solecki et al. [11], the actual solid is replaced with finite elements of relatively simple shapes to approximate the curved boundary of the actual solid to determine the assumed behaviour of the individual elements.

The structural behaviours exerted in both flat slabs and two-way slabs with beams are similar, where the slab cracks on the top surface near the column first before proceeds to crack at midspan and at the bottom part [6]. The behaviour of the flat slab was severely affected in the presence of applied loads, where it then resulted in deflections and the slab eventually failed [12]. Besides, Baniya et al. [13] reported that the stress behaviour in slabs is influenced by the strength of loads applied.

Besides analysing and designing the reinforced concrete flat slab in accordance to Eurocode 2 (EC2), the objectives of this study are to develop a design table for reinforced concrete flat slab subjected to uniformly distributed load and to investigate the effect of line load applied on the reinforced concrete flat slab.

2. Methodology

This section describes and explains the methodology applied throughout this research work.

2.1 Research Flowchart

The research work approach used to design the slabs was based on Eurocode 2 and it was adapted from that used by Sinha (2014) which focuses on the proportioning of the flat slab components, the loadings of the flat slabs design from “Institution of Structural Engineers” (2006) while the design of structural elements was adapted from that by Beeby and Narayanan (2005). The research adapted the comparative analysis approach [14] to compare and determine the structural behavioural changes for the proposed designs of reinforced concrete flat slabs when subjected to loadings. Design details were proposed using the specification stated in EC2. The uniformly distributed load (UDL) applied on the flat slab with square panel design variations were then analysed using the structural analysis software to propose the design table of flat slab and to investigate the structural behaviours of flat slabs when it was subjected to line load using a finite element package. The designs variations were the flat slab span, slab thickness and drop length. The patterns of the structures when line loads were subjected at the flat slab connection were recognized and their structural behaviours of the reinforced concrete flat slab when subjected to line load were investigated.

2.2 Development of Design Table

The typical detailing of reinforced concrete flat slabs comprised of its span, slab thickness and drop length are shown in Figure 1.

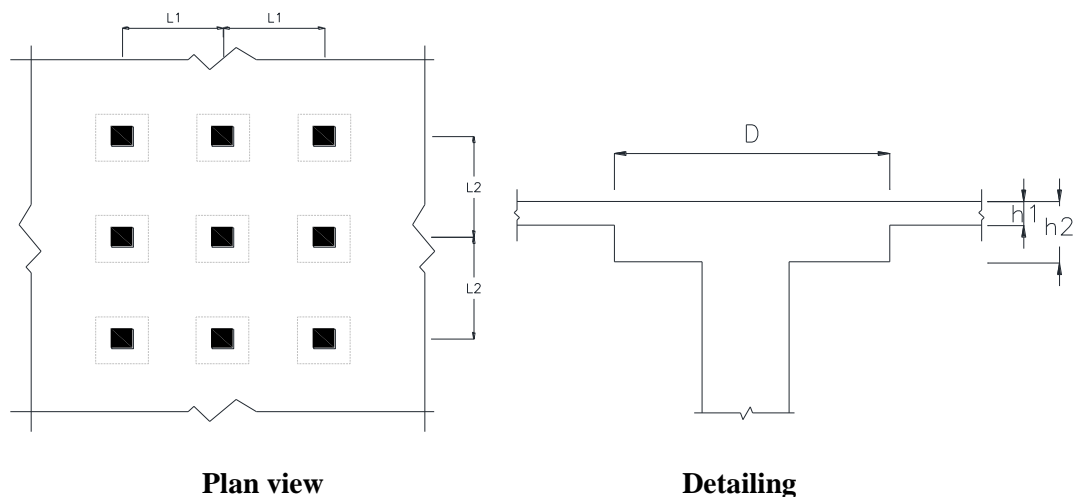

Note: L1= Span; L2= Span h1= Slab thickness; h2= Drop Length; D= Critical section

Figure 1: Typical Detailing of the Reinforced Concrete Flat Slabs

The dimensions, loading actions and the design parameters applied on the slabs were proposed to determine the design table. The proposed dimensions were of EC2 requirements, where the slab thickness was of the minimum of 125 mm, satisfied the span to depth ratio and as of the thickness specified, drop length ranging between 1.25 to 1.5 times of the slab thickness and the column size was fixed to be squared column at 500x500 mm dimensions.

The permanent action for all the proposed designs of the reinforced concrete flat slabs involved the self-weight of the flat slab and the slab finishes. The unit weight of concrete for a C25/30 strength and the slab finishes were considered to be 25.0 kN/m³ and 1.3 kN/m² respectively in accordance to EC2. However, in the case of variable action, each of the designs was loaded with uniformly distributed load (UDL) of 2.5 kN/m², 5.0 kN/m² and 7.5 kN/m² respectively.

The design parameters such as the characteristics compressive strength of concrete, f_{ck} , characteristics yield strength of reinforcement, f_{yk} , elastic modulus of steel, E_s , concrete cover and floor height were fixed throughout the research work, which were 30 N/mm^2 , 500 N/mm^2 , 200000 N/mm^2 , 30 mm and 3000 mm respectively.

Table 1: Proposed dimensions of squared reinforced concrete flat slab design with variation on span, slab thickness and drop length

No.	L1, L2 (m)	h_1 (mm)	h_2 (mm)
1	4	160	200
2	5	200	260
3	6	250	350
4	7	300	400
5	8	325	450

2.2.1 Design of Shear Capacity

The design shear resistance was a crucial step to determining whether the flat slab structure is prone to punching shear failure, and thus, to determine if shear reinforcement is required.

The shear at the perimeter of the column and the shear at basic control perimeter of column were checked by comparing the maximum shear stress at column face, $v_{Ed,max}$ and the maximum shear resistance capacity, $v_{Rd,max}$. The maximum shear stress at column face, $v_{Ed,max}$ must not exceed the maximum shear resistance capacity, $v_{Rd,max}$.

The maximum shear stress at perimeter column face and shear stress at basic control perimeter, $v_{Ed,max}$ were acquired using Eq. 1 and 2, where β is the factor dealing with eccentricity with each equal to 1.15 for interior column, 1.4 for column at edge and 1.5 for column at corner, where the perimeter at the column face, u_0 at interior column, edge column and column at corner is $u_0 = 2(c_1+c_2)$, $u_0 = c_2+3d \leq c_2 + 2c_1$ and $u_0 = 3d \leq c_2+2c_1$ while the basic control perimeter at the column face, u_1 at interior column, edge column and column at corner is $u_1 = 2(c_1+c_2) + 2\pi \times 2d$, $u_1 = c_2+3d + 2\pi \times 2d$ and $u_1 = 3d + 2\pi \times 2d$, with c_1 and c_2 each being the respective column depth and column width.

The maximum shear resistance capacity, $v_{Rd,max}$ was derived and rearranged as in Eq. 3.

$$v_{Ed,max} = \frac{\beta V_{Ed}}{u_0 d} \quad \text{Eq. 1}$$

$$v_{Ed,max} = \frac{\beta V_{Ed}}{u_1 d} \quad \text{Eq. 2}$$

$$v_{Rd,max} = 0.5 \times 0.6(1 - f_{ck}/250) \times \alpha_{cc} f_{ck} / \gamma_m \quad \text{Eq. 3}$$

To check the punching shear capacity, the design shear resistance, $v_{Rd,c}$ acquired should be larger than the minimum shear resistance, v_{min} and the maximum shear stress, $v_{Ed,max}$.

$$v_{Rd,c} = \left[0.12k(100\rho_1 f_{ck})^{\frac{1}{3}} \right] \quad \text{Eq. 4}$$

$$v_{min} = \left[0.0035k^{3/2} f_{ck}^{1/2} \right] \quad \text{Eq. 5}$$

2.2.2 Design of Structural Elements

Simplified coefficients method was used to analyse the structures of the reinforced concrete flat slabs as there were more than three equal spans on the slab and were subjected predominantly to UDL [15] For top reinforcement, the percentage coefficient for the design moments distribution were taken as 70% and 30% for the column and middle strips, Whereas for the bottom reinforcement, the

percentage coefficient for the design moments distribution were taken as 50% for both column and middle strips.

The longitudinal reinforcement followed the methods of limit state design for reinforced concrete design adapted from EC2, by utilising the maximum bending moment resulted from the software analysis. The area of steel reinforcement, A_s was obtained by using Eq. 6, where M is the maximum bending moment, f_{yk} was the characteristics yield strength of steel reinforcement and z was the lever arm for the applied moment. According to Beeby and Narayanan [15], the minimum area for the vertical reinforcement was 20% of the longitudinal reinforcement area. The total area of reinforcement, $A_{s,Total}$ was calculated by summing up the required area of reinforcement, $A_{s,Req}$ for the column strip multiplying with its width and the required area of reinforcement, $A_{s,Req}$ for the middle strip multiplying with its width. Then, the area of reinforcement required to spread over the column area was determined by dividing 50% of the $A_{s,Total}$ with 0.5 of the width of the column strip. Finally, the area of reinforcement for the remaining column strip was calculating by using Eq. 7.

$$A_{s,required} = \frac{M}{0.87 \times f_{yk} \times z} \quad \text{Eq. 6}$$

$$A_{s,required} = \frac{A_{s,required} \text{ for column area} \times \text{span} - 50\% \text{ of the } A_{s,total}}{0.5 \times \text{width of column strip}} \quad \text{Eq. 7}$$

The area of reinforcements for the longitudinal reinforcements used in the slabs were needed to satisfy to the minimum and maximum reinforcement requirements. Based on EC2, for f_{ck} over or equal to 25MPa, the minimum area and maximum area of reinforcement requirements are obtained using the derived equations in Eq. 8 and 9.

$$A_{s,min} = 0.0015bd \quad \text{Eq. 8}$$

$$A_{s,max} = 0.4A_c \quad \text{Eq. 9}$$

2.3 Structural Behaviour of Reinforced Concrete Flat Slabs when Subjected to Line Load

The reinforced concrete flat slabs tested for line load study were limited to square and rectangular dimensions only. Drop panels were included in each of the design variations and the supported columns were fixed to be square column at 500x500 mm dimension. The proposed dimensions were of EC2 requirements, where the slab thickness was of the minimum of 125 mm, satisfied the span to depth ratio and as of the thickness specified, and drop length ranging between 1.25 to 1.5 times of the slab thickness. The proposed designs of reinforced concrete flat slab for the line load study on the flat slabs is shown in Table 2.

Table 2: Proposed designs of reinforced concrete flat slab for the line load study

Slab.	L1 (m)	L2 (m)	h ₁ (mm)	h ₂ (mm)
I	8	8	325	450
II	8	4	325	450

The line load was fixed at 20 kN/m while four load cases were applied on each of the variation designs of the reinforced concrete flat slabs, they were line load at column strip, line load at middle strip, line load at column strip and middle strip, and line load at irregular locations, which are shown in Figure 2. The assumptions of design parameters such as material properties of the flat slab were identified and input into the software system. The design parameters such as the unit weight of concrete, the characteristics compressive strength of concrete, f_{ck} , characteristics yield strength of reinforcement, f_{yk} , elastic modulus of steel, E_s , concrete cover and floor height were fixed throughout the research work, which were C25/30 strength, 30 N/mm², 500 N/mm², 200000 N/mm², 30 mm and 3000 mm respectively. The analysis was performed using the finite element package ESTEEM v9.2.45.0 to

generate the respective sets of results. Thereafter, the structural behaviours of the reinforced concrete flat slab caused by the effect of the applied load cases were investigated.

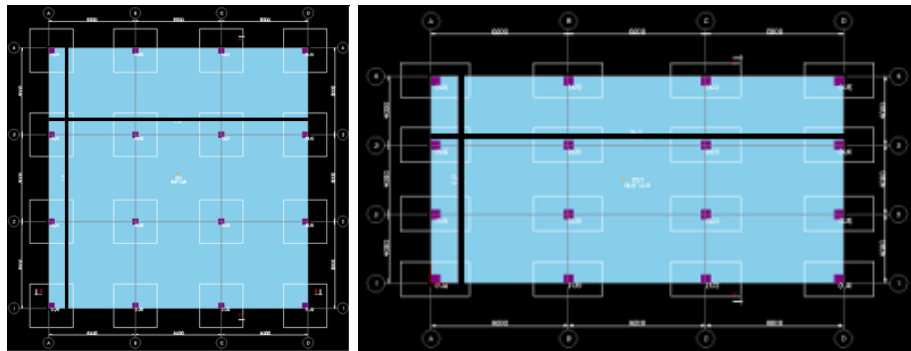

Case 1: Line load at column strip

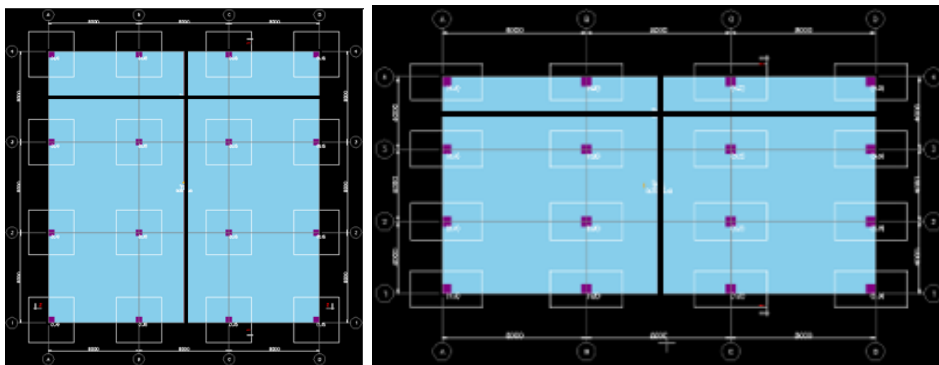

Case 2: Line load at middle strip

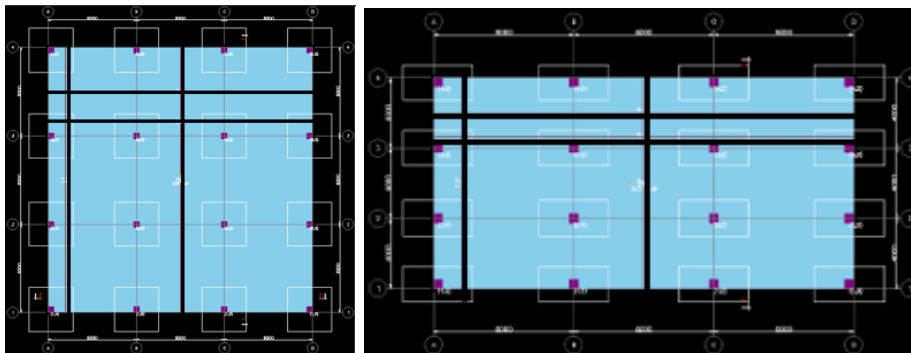

Case 3: Line load at column and middle strip

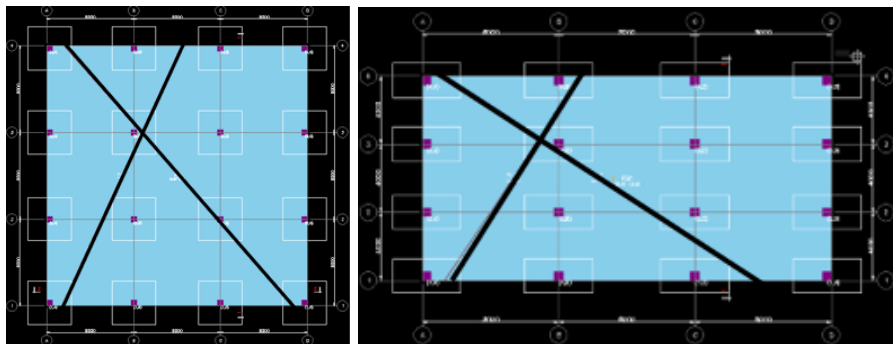

Case 4: Line load at irregular locations

Figure 2: Typical Detailing of the Reinforced Concrete Flat Slabs

3. Results and Discussion

3.1 Analysis of Reinforced Concrete Flat Slabs

The maximum vertical displacement of flat slabs when subjected to UDL and its percentage of maximum displacement occupied and maximum moments in X and Y directions of flat slabs when subjected to UDL and their percentage of maximum occupied is shown in Table 3 and Table 4.

Table 3: Maximum vertical displacement of flat slabs when subjected to UDL and its percentage of maximum displacement occupied

No.	Span (m)	UDL (kN/m ²)	Displacement (mm)	% Displacement
1.	4	2.5	1.43	25.44
		5.0	1.87	33.27
		7.5	2.32	41.28
2.	5	2.5	1.50	26.09
		5.0	1.92	33.39
		7.5	2.33	40.52
3.	6	2.5	2.51	26.90
		5.0	3.11	33.33
		7.5	3.71	39.76
4.	7	2.5	3.52	27.46
		5.0	4.27	33.31
		7.5	5.03	39.24
5.	8	2.5	5.12	27.75
		5.0	6.15	33.33
		7.5	7.18	38.92

Table 4: Maximum moments in X and Y directions of flat slabs when subjected to UDL and their percentage of maximum displacement occupied

No.	Span (m)	UDL (kN/m ²)	X-direction			Y-direction		
			Max. Negative Moment, kNm	Max. Positive Moment, kNm	% Max. Negative Moment	Max. Negative Moment, kNm	Max. Positive Moment, kNm	% Max. Negative Moment
1.	4	2.5	46.55	15.33	24.96	46.34	15.52	24.95
		5.0	62.17	20.41	33.33	61.90	20.66	33.33
		7.5	77.79	25.48	41.71	77.46	25.80	41.71
2.	5	2.5	92.41	18.41	25.73	91.97	17.15	25.73
		5.0	119.73	23.93	33.33	119.16	22.30	33.33
		7.5	147.05	29.45	40.94	146.35	27.45	40.94
3.	6	2.5	188.54	90.02	26.53	193.83	89.91	26.53
		5.0	236.9	113.33	33.33	243.53	113.19	33.33
		7.5	285.25	136.64	40.14	293.23	136.47	40.14
4.	7	2.5	290.81	95.63	27.10	298.89	95.65	27.10
		5.0	357.64	117.84	33.33	367.6	117.87	33.33
		7.5	424.48	140.06	39.56	436.31	140.10	39.56
5.	8	2.5	441.95	121.96	27.40	450.77	121.94	27.40
		5.0	537.56	148.76	33.33	548.30	148.73	33.33
		7.5	633.18	175.55	39.26	645.84	175.52	39.26

Based on the results in Table 3 and Table 4, it can be interpreted that positive displacements tend to occur near the corner columns of the flat slabs compared to other areas on the slab, and the displacements caused by applied UDL increase as the length of spans of the flat slabs increase. The forces of reinforcement in X and Y directions developed were in a similar manner. The overall applied UDL on the flat slabs caused higher bending moments at the top slab compared to bending moments at the bottom slab. The moments affected on the span of reinforced concrete flat slabs increase as the UDL applied on the flat slabs increase. The moments affected on the reinforced concrete flat slabs increase as the length of spans, slab and drop increase.

3.2 Development of the Design Table

The design of the longitudinal reinforcements in the reinforced concrete flat slabs was based on the maximum bending moment in both x and y direction that appointed onto the slab, calculated using direct design method and limit state design, and comply with minimum and maximum reinforcement areas in accordance to EC2. Punching shear analysis was done to check the shear reinforcement of the flat slabs. Shear reinforcement is not required when the shear strength is within the maximum shear resistance in the flat slabs [16]. The design table for reinforced concrete subjected to uniformly distributed load and the typical plan and detailing are illustrated in Table 5 and Figure 4.

Table 5: Design table for reinforced concrete flat slab subjected to uniformly distributed load

No.	L _x / L _y (m)	h ₁ (mm)	h ₂ (mm)	D (mm)	UDL (kN/m ²)	Top Reinforcement			Bottom Reinforcement
						T1	T2	T3	B1
1.	4	160	200	2000	2.5	Use H12-425 (266 mm ² /m)	Use H10-375 (210 mm ² /m)	Use H12-150 (754 mm ² /m)	Use H12-250 (453 mm ² /m)
					5.0	Use H12-300 (377 mm ² /m)	Use H10-300 (262 mm ² /m)	Use H12-125 (905 mm ² /m)	Use H12-175 (647 mm ² /m)
					7.5	Use H16-425 (473 mm ² /m)	Use H12-300 (377 mm ² /m)	Use H16-175 (1149 mm ² /m)	Use H16-250 (805 mm ² /m)
2.	5	200	260	2500	2.5	Use H12-300 (377 mm ² /m)	Use H10-300 (262 mm ² /m)	Use H12-125 (905 mm ² /m)	Use H12-250 (453 mm ² /m)
					5.0	Use H16-325 (619 mm ² /m)	Use H12-300 (377 mm ² /m)	Use H16-175 (1149 mm ² /m)	Use H16-375 (536 mm ² /m)
					7.5	Use H16-375 (536 mm ² /m)	Use H12-300 (377 mm ² /m)	Use H16-150 (1341 mm ² /m)	Use H16-250 (805 mm ² /m)
3.	6	250	350	3000	2.5	Use H16-375 (536 mm ² /m)	Use H12-300 (377 mm ² /m)	Use H16-175 (1149 mm ² /m)	Use H16-125 (1609 mm ² /m)
					5.0	Use H16-300 (670 mm ² /m)	Use H12-250 (453 mm ² /m)	Use H16-150 (1341 mm ² /m)	Use H16-100 (2011 mm ² /m)
					7.5	Use H20-475 (662 mm ² /m)	Use H16-375 (536 mm ² /m)	Use H20-175 (1796 mm ² /m)	Use H20-125 (2514 mm ² /m)
4.	7	300	400	3500	2.5	Use H16-375 (536 mm ² /m)	Use H12-300 (377 mm ² /m)	Use H16-175 (1149 mm ² /m)	Use H16-150 (1341 mm ² /m)
					5.0	Use H16-325 (619 mm ² /m)	Use H12-250 (453 mm ² /m)	Use H16-125 (1609 mm ² /m)	Use H16-125 (1609 mm ² /m)
					7.5	Use H20-475 (662 mm ² /m)	Use H16-375 (536 mm ² /m)	Use H20-175 (1341 mm ² /m)	Use H20-150 (2095 mm ² /m)
5.	8	325	450	4000	2.5	Use H16-475 (423 mm ² /m)	Use H12-325 (348 mm ² /m)	Use H16-200 (1006 mm ² /m)	Use H16-125 (1609 mm ² /m)
					5.0	Use H20-425 (740 mm ² /m)	Use H16-375 (536 mm ² /m)	Use H20-175 (1796 mm ² /m)	Use H20-150 (2095 mm ² /m)
					7.5	Use H20-375 (838 mm ² /m)	Use H16-325 (619 mm ² /m)	Use H20-150 (2095 mm ² /m)	Use H20-125 (2514 mm ² /m)

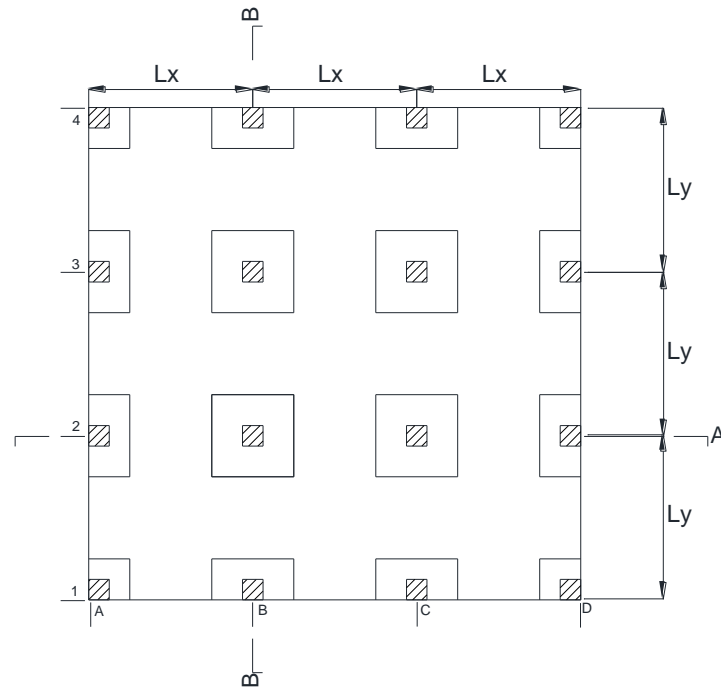

Typical Plan View

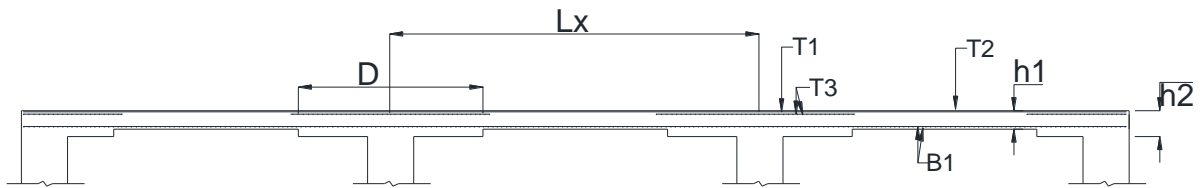

Section A-A

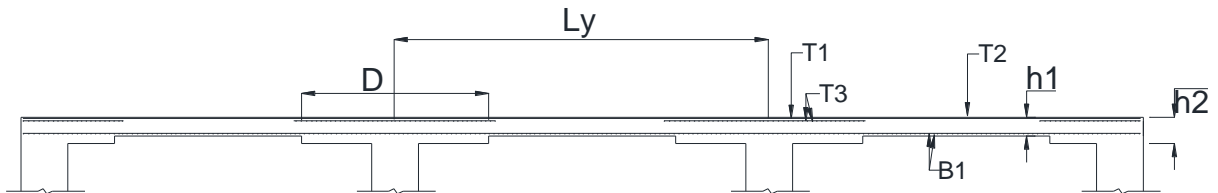

Section B-B

- Note:
- Lx = Span;
 - Ly = Span;
 - h1 = Slab Thickness;
 - h2 = Drop Length;
 - D = Critical section;
 - T1 = Top Reinforcement at Column Strips;
 - T2 = Top Reinforcement at Middle Strips;
 - T3 = Reinforcement at Column Area;
 - B1 = Bottom Reinforcement at Column and Middle Strips

Figure 4: Typical Detailing of the Reinforced Concrete Flat Slabs

3.3 Structural Behaviours of Reinforced Concrete Flat Slabs when Subjected to Line Load

The maximum displacements and design moments at variations on conditions and slabs, and its percentage difference between the flat slabs on line load conditions and at controlled condition, the percentage occupied for maximum displacements and design moments at the 4 conditions among Slab I and Slab II, and the percentage occupied for maximum displacements and design moments on Slab I and Slab II at variations on conditions are shown in Table 6, Table 7 and Table 8.

Table 6: Maximum displacements and design moments at variations on conditions and slabs, and its percentage difference between the flat slabs on line load conditions and at controlled condition

No.	Condition	Slab	Displacement (mm)	Moment (kNm)		Displacement (%)	Moment (%)	
				Negative Moments	Positive Moments		Negative Moments	Positive Moments
1.	A	I	5.44	551.49	169.69	60.51	56.15	59.22
2.		II	2.91	303.95	103.43	62.45	59.79	63.61
3.	B	I	5.36	602.41	169.12	60.16	58.31	59.14
4.		II	2.16	318.17	79.38	55.24	60.89	57.29
5.	C	I	6.77	718.24	204.57	65.60	62.51	63.65
6.		II	3.26	421.36	119.44	65.07	67.34	66.87
7.	D	I	4.99	642.43	151.24	58.43	59.86	56.42
8.		II	2.89	339.85	98.71	62.28	62.44	62.52

Table 7: Percentage occupied for maximum displacements and design moments at the 4 conditions among Slab I and Slab II

No.	Condition	Slab	Displacement (%)	Moment (%)		Total (%)
				Negative Moments	Positive Moments	
1.	A	I	65.15	64.47	62.13	100.00
2.		II	34.85	35.53	37.87	
3.	B	I	71.28	65.44	68.06	100.00
4.		II	28.72	34.56	31.94	
5.	C	I	67.50	63.03	63.14	100.00
6.		II	32.50	36.97	36.86	
7.	D	I	63.32	65.40	60.51	100.00
8.		II	36.68	34.60	39.49	

Table 8: percentage occupied for maximum displacements and design moments on Slab I and Slab II at variations on conditions

No.	Condition	Slab	Displacement (%)	Moment (%)	
				Negative Moments	Positive Moments
1.	A	I	24.11	21.93	24.43
2.		II	25.94	21.97	25.80
3.	B	I	23.76	23.96	24.35
4.		II	19.25	23.00	19.80
5.	C	I	30.01	28.56	29.45
6.		II	29.06	30.46	29.79
7.	D	I	22.12	25.55	21.77
8.		II	25.76	24.57	24.62

The interpretations of the analysis of the structural behaviour of the flat slabs subjected to line load are summarised as follow:

Firstly, reinforced concrete flat slabs are significantly affected by the line load in terms of displacement and moments regardless of the areas of slabs (Comparison between with load and without load (control) indicated increase in displacement with different range from 55.24% to 65.60%, increase in negative moment from 56.15% to 67.34% and increase in positive moment from 56.42% to 66.87%; these percentage are significantly high).

Secondly, changes in the structural behaviours tend to occur near the columns of the flat slabs as compared to other areas of the slab, and it was higher especially when line load was applied directly on the column and middle strips.

Next, Slab I showed significant changes in structural behaviours as compared to Slab II when subjected to line load conditions (Slab I at Condition A, B, C and D indicated percentage occupied for displacement range from 63.32% to 71.28%, for positive moment range from 63.03% to 65.44% and for negative moment range from 60.51% to 68.06%, while Slab II at Condition A, B, C and D indicated percentage occupied for displacement range from 28.72% to 36.68%, for positive moment range from 34.56% to 36.97% and for negative moment range from 31.94% to 39.49%; the displacement and moment percentages respectively indicate the changes are significant).

Besides, the reinforced concrete flat slabs were affected most critically at Condition C (Line loads on middle and column strips) in both Slab I and II (Percentage occupied at slab I and II for displacement range from 29.06% to 30.01%, for positive moment range from 28.56% to 23.96% and for negative moment range from 19.80% to 24.35%), while it was least affected by line loads at Condition B (Line loads on middle strips) in Slab I and Slab II (Percentage occupied at slab I and II for displacement range from 19.25% to 23.76%, for positive moment range from 23.00% to 30.46% and for negative moment range from 29.45% to 29.79%; the percentage indicate that the locations of line load on the middle strip is significantly stronger than line load on middle and column strips).

3.4 Discussion

This research is meant to analyse the reinforced concrete flat slabs using finite element method. The overall result of this research indicates that dimensions and loadings on flat slabs are related towards the structures. This finding is in line with [17] who found that positive bending moment caused sagging where the slab concave upwards and hogging occurred when the slab concave downwards while [18] found that displacements in flat slabs are more crucial than in conventional slabs of same thickness.

The designs of the flat slabs system followed the direct design method guided in EC2. Punching shear analysis was done for the reinforced concrete flat slabs to ensure the flat slabs are able to resist punching shear notably at the critical region surrounding column areas [15]. However, based on the claim by [16], shear reinforcement is not required when the shear strength of concrete is greater than the total shear stress in a flat slab.

Literature review of the relationship on structural behaviours in flat slabs generally show significant correlation between applied loadings on slabs with displacements and moments, especially loadings surrounding the column areas [12][13]. The moments in symmetrical slabs are higher than in asymmetrical slabs [19]. This research found that the locations of line load significantly affect the structural behaviours in reinforced concrete flat slabs in terms of areas, displacements and moments. It was observed that the line loads emitted at both column and middle strips resulted with greater structural behaviour changes in a symmetrical slab than in an asymmetrical slab at the same condition. This finding is consistent with work by [20] where the areas surrounding or near the column showed greater changes of structural behaviours in a reinforced concrete slab.

4. Conclusion

This research had revealed the effect of uniformly distributed loads (UDL) and variations of line load locations applied towards the design of reinforced concrete flat slabs. This study showed that the variations of dimensions and uniformly distributed loads (UDL) were significantly related to the design strength of the reinforced concrete flat slabs and the length of spans and locations of line loads on reinforced concrete flat slabs were significantly related to the design strength of the reinforced concrete flat slabs.

Aside from developing a design table for reinforced concrete flat slab with variations in span and loadings to cater for various situations and independent usage, this study has also contributed a better understanding of the structural behaviours of reinforced concrete flat slabs when subjected to line loads at different locations.

For future investigation, a statistical analysis between different the extent and directions of line loads on reinforced concrete flat slabs can be carried out to improve the analysis and design of reinforced concrete flat slab subjected to line load.

This research had been limited to subjecting line load on reinforced concrete flat slab and comprised of square columns connection only. Future scope of study could include analysis and designs on the supported columns of the reinforced concrete flat slabs.

Acknowledgement

The authors wish to thank the Faculty of Civil Engineering and Built Environment, Universiti Tun Hussein Onn Malaysia for its support.

References

- [1] I. G. Shaaban, A.H. Hosni, W.M. Montaser and M.M. El-Sayed, "Effect of premature loading on punching resistance of reinforced concrete flat slabs". Elsevier, Case Studies in Construction Materials, Vol. 12, (e00320), 2020.
- [2] K. Qian and B. Li, "Resilience of Flat Slab Structures in Different Phases of Progressive Collapse". Aci Structural Journal, Vol. 113(3).
- [3] R.K.S.A. Hamda, M. Gillie, H. Warren, G. Torelli, T. Stratford and Y.Wang, "The effect of load-induced thermal strain on flat slab behaviour at elevated temperatures". Elsevier, Fire Safety Journal, Vol. 97, pp. 12 – 18, 2018.

- [4] M.M.G. Inácio, A.F.O. Almeida, D.M.V. Faria, V.J.G. Lúcio and A.P. Ramos, “Punching of high strength concrete flat slabs without shear reinforcement,” Elsevier, Engineering Structures, Vol. 103, pp. 275 – 284, 2015.
- [5] J. Gomes, R. Carvalho, C. Sousa, J. Granja, R. Faria, D. Schlicke and M. Azenha, “3D numerical simulation of the cracking behaviour of a RC one-way slab under the combined effect of thermal, shrinkage and external loads,” Elsevier, Engineering Structures, Vol. 212, (110493), 2020.
- [6] N. Subramaniam, Design of Reinforced Concrete Structures. Oxford University Press, 2013.
- [7] R. Park and W.L. Gamble, Reinforced concrete slabs. Second edition, John Wiley & Sons, Inc, ISBN 0-471-34850-3, 2000.
- [8] F. Fu, Design and Analysis of Tall and Complex Structures. Elsevier, 2018.
- [9] ACI Committee 360, Design of Slabs-on-ground, American Concrete Institute, p.p 360R-19, 2006. Available: Google Books, books.google.com.my [Accessed: 9 April 2020].
- [10] L. Hollaway and M. B. Leeming, Strengthening of reinforced concrete structures: Using externally-bonded FRP composites in structural and civil engineering, Boca Raton, FL: CRC Press, 1999.
- [11] R. Solecki, J.R. Conant, Advanced Mechanics of Materials. Oxford University Press, ISBN: 978-0195143720, 2003.
- [12] A. Torabian, B. Isufi, D. Mostofinejad and A.P. Ramos, “Behavior of thin lightly reinforced flat slabs under concentric loading,” Engineering Structures, Vol. 196, Elsevier, 2019.
- [13] W.J. Baniya, W. Zaki, C-M. R. Farrag and D-A. Rashed, “Behavior of composite pre-flat slabs in resisting punching shear forces”, Elsevier, Alexandria Engineering Journal, Vol. 59(1), pp. 333 – 347, 2020.
- [14] C.G. Pickvance, “Four varieties of comparative analysis,” Journal of Housing and the Built Environment, Kluwer Academic Publishers, Netherlands, Vol. 16, (pp. 7 – 28), 2001.
- [15] A.W. Beeby and R.S. Narayanan. Designers’ Guide to Eurocode 2 – Design of Concrete Structures EN 1992-1-1 and EN 1992-1-2. ICE Publishing, 2005.
- [16] S.N. Sinha. Reinforced Concrete Design (Second Revised Edition). Tata McGraw-Hill Education. ISBN: 978-0-07-047332-4, 2002
- [17] G.C. Mrema. Rural structures in the tropics: design and development. Rome: FAO, 2011.
- [18] F. Aseem, W. Sohail and A. Quadir, “ Analysis and Comparison of R.C.C Conventional Slab & Flat Slab Under Seismic & Temperature Load,” International Research Journal of Engineering and Technology (IRJET), Vol. 4(10), p.p (1370 – 1376), E-ISSN: 2395-0056, 2017.
- [19] A. Puel and D.D. Loriggio, “Numerical analysis of symmetrical and asymmetrical reinforced concrete flat slabs - an integrated slab/ column analysis,” Revista IBRACON de Estruturas e Materiais, Vol. 9(3), São Paulo, ISSN 1983-4195.
- [20] N. Galati, A. Nanni, J.G. Tumialan and P.H. Ziehl, “ In-Situ Evaluation of Two Concrete Slab Systems. I: Load Determination and Loading Procedure,” Journal of Performance of Constructed Facilities, Vol. 22 (4), pp. (207 – 216), 2008.